

# NACIONAL MOTOR, S.A.U. DERBI

C/ Barcelona, nº19 - Martorelles 08107 - BARCELONA (SPAIN)  
Tel. 93 565 78 78 - Fax 93 565 78 52

---

# DERBI



---

## GP1 LOW SEAT 250cc 2007 E3

---

CÓDIGO CATÁLOGO  
CATALOGUE NUMBER

7077CG07007



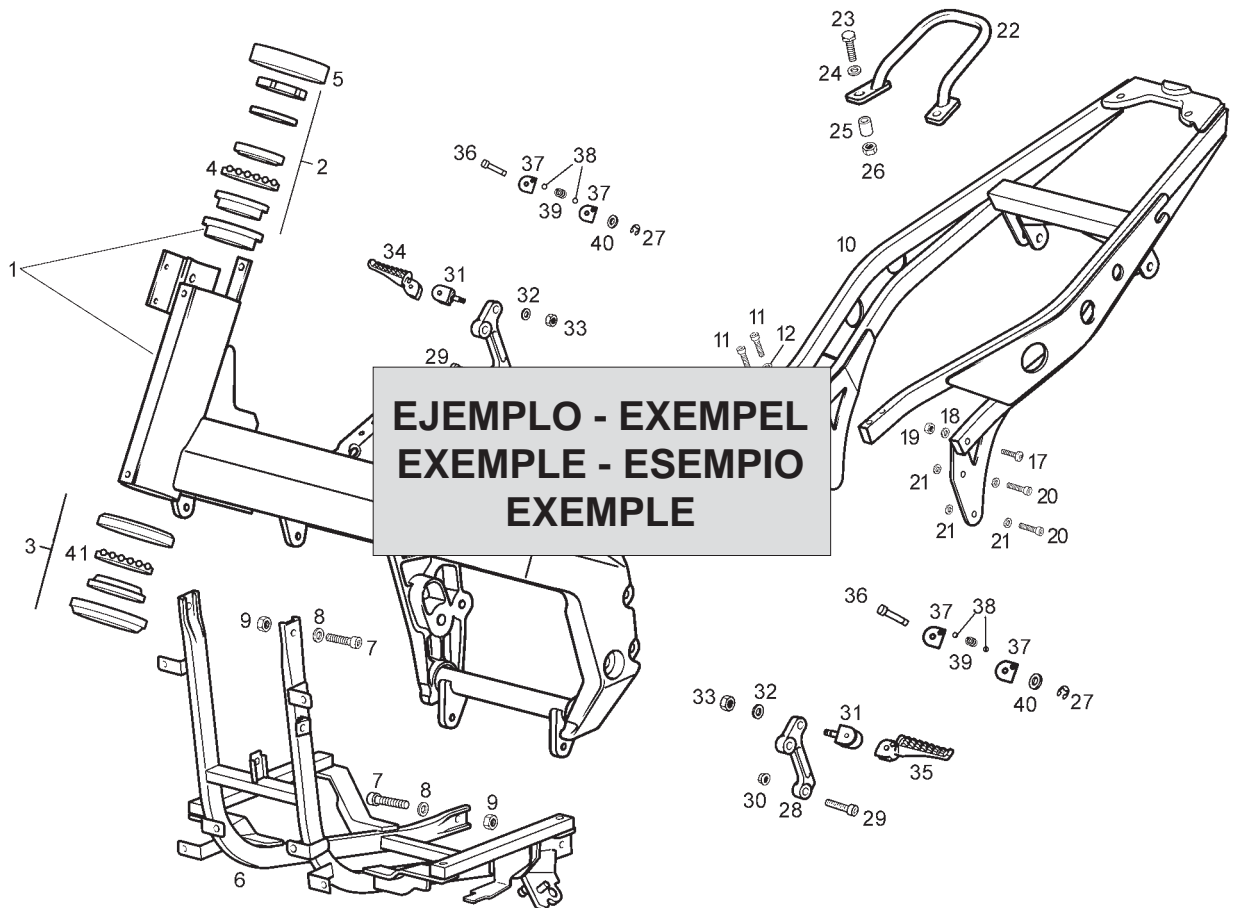

Fig.	Ver.	COD. KOD.	DESCRIPCIÓN DENOMINAZIONE NAME	BEZEICHUNG DESIGNATION	MOD.	NOTAS NOTES MITSCHRIFT NOTES
		00G01924601	R-SCTO.CUADRO C/COJIN. ATLANTIS TELAIO FRAME SUB-ASSEMBLY	RHAMEN CADRE COMPLET	12	XXXXXXX
②						
	01	00G01924601	R-SCTO.CUADRO C/COJIN. ATLANTIS TELAIO FRAME SUB-ASSEMBLY	RHAMEN CADRE COMPLET	12	XXXXXXX
③						
	02	00G01924601				
④						
	03	00G01924601	R-SCTO.CUADRO C/COJIN. ATLANTIS TELAIO FRAME SUB-ASSEMBLY	RHAMEN CADRE COMPLET	12	XXXXXXX
①		⑤		⑧	⑥	⑦

1- Código de localización de piezas. 2- Código indicativo de pieza reemplazada. 3- Código indicativo de pieza anulada. 4- Código indicativo de pieza restituida (esta se monta de nuevo). 5- Código de referencia de la pieza. 6- Identificación de modelos. 7- Los códigos de esta casilla indican que, a partir del número de chasis o motor indicado dentro de esta, se monta una nueva pieza que reemplaza a la anterior (sección 2), que una pieza no se monta (sección 3), o que la pieza anulada se monta de nuevo (sección 4), y concierne a los modelos indicados (sección 6). 8- Denominación de la pieza.

1- Codice di localizzazione pezzi. 2- Codice indicatore del pezzo sostituito. 3- Il pezzo precedente non si monta. 4- Codice indicatore dei pezzi che si tornano a montare. 5- Codice di identificazione del pezzo. 6- Identificazione del modello. 7- Il codice di questa casella indica che, dal numero di Telaio/motore indicato, si monta un nuovo pezzo che sostituisce il precedente (sezione 2), che un pezzo non si monta (sezione 3), oppure che il pezzo annullato si monta di nuovo (sezione 4), facendo riferimento al modello indicato (sezione 6). 8- Denominazione del pezzo.

1- Part location number. 2- Substituted part number. 3- Withdrawn part number (no longer fitted). 4- Restored part number (newly fitted going withdrawn). 5- Part reference number. 6- Model identification number. 7- Chassis or engine number from which a new part is fitted substituting a part which has been withdrawn (see para 2) or a part is withdrawn is fitted again (see para 4), in the models indicated (see para 6). 8- Part identification label.

1- Zeichnungs - Nummer. 2- Ausführung. 3- Gestrichene Ersatzteilnummer. 4- Ersetzte Ersatzteilnummer. 5- Ersatzteilnummer. 6- Modell - Nummer. 7- Rhamen - order motonummer, für die ein neues teil eingestzt wird, z.b. eine nummer, die geändert (s. para 2), order ein teil, das gestrichen wurde (s. para 3), order ein teil, das vorübergehend verschiedene modelle (s. para 6) 8- Bezeichnung.

1- Code de localisation de la pièce. 2- Code indicateur de pièce remplace par un autre. 3- Code indicateur de pièce annulé (elle n'est plus montée). 4- Code indicateur de pièce restituée (elle se monte à nouveau). 5- Code référence de la pièce. 6- Les codes de cette case indiquant qu'à partir de numero 7- Chassis ou de moteur indiqué, un nouvelle pièce est montée en remplacement d'une autre (section 2), qu'une pièce n'est plus montée (section 3) ou la pièce anulée est montée à nouveau (section 4) et concernant les modèles indiqués (section 6). 8- Denomination de la pièce.

**IDENTIFICACION DE MODELOS REPRESENTADOS EN ESTE  
CATALOGO SEGUN LOS DIGITOS SIGUIENTES**

















**IDENTIFICAZIONE DEI MODELLI RAPPRESENTATI IN QUESTO CATALOGO  
SECONDO I NUMERI A SEGUIRE**

**THE MODELS REFERRED INTO THIS CATALOGUE ARE IDENTIFIED  
BY FOLLOWING NUMBERS**

**BESTIMMUNG DER VERSCHIEDENEN MODELLE IN DIESEM KATALOG**

**IDENTIFICATION DES MODELOES REPRESENTES DANS CE CATALOGUE,  
EN FUNCTION DES CODES SUIVANTS**

MODELO MODELLI MODEL MODELL MODELE	DENOMINACION DENOMINAZIONE MODEL NAME BEZEICHNUNG DENOMINATION	CODIGO MODELO CODICE MODELLI CODE MODEL KODE MODELL CODE MODELE
1	GP1 250cc LOW SEAT ESPAÑA <b>NEGRO (OMBU)</b> 2007 E3 GP1 250cc LOW SEAT FRANCE <b>BLACK (OMBU)</b> 2007 E3 GP1 250cc LOW SEAT ENGLAND <b>BLACK (OMBU)</b> 2007 E3 GP1 250cc LOW SEAT ITALY <b>BLACK (OMBU)</b> 2007 E3 GP1 250cc LOW SEAT JAPAN <b>BLACK (OMBU)</b> 2007 E3	E 9 2G55E 7 80 E 9 2G55F 7 80 E 9 2G55G 7 80 E 9 2G55 I 7 80 E 9 2G55J 7 80
2	GP1 250cc LOW SEAT ESPAÑA <b>GRIS (ADELFA)</b> 2007 E3 GP1 250cc LOW SEAT FRANCE <b>GREY (ADELFA)</b> 2007 E3 GP1 250cc LOW SEAT ENGLAND <b>GREY (ADELFA)</b> 2007 E3 GP1 250cc LOW SEAT ITALY <b>GREY (ADELFA)</b> 2007 E3 GP1 250cc LOW SEAT JAPAN <b>GREY (ADELFA)</b> 2007 E3	E 9 2G55E 7 70 E 9 2G55F 7 70 E 9 2G55G 7 70 E 9 2G55 I 7 70 E 9 2G55J 7 70

IMAGEN FIGURE	LAMINA DIAGRAM	POSICION POSITION	CODIGO CODE	DESCRIPCION ESPAÑOL / SPANISH DESCRIPTION DESCRIPCION INGLES / ENGLISH DESCRIPTION	CANT. POR MOTO QTY PER BIKE	NOTES NOTES
	09	05A	00G00909071	EMPUÑADURA LADO IZQUIERDO LEFT GRIP	1	
	09	07A	00G00910081	CTO PUÑO GAS THROTTLE GRIP ASSY	1	
	09	11A	00G00903201	MANETA FRENO TRASERO REAR BRAKE LEVER	1	
	09	20A	00G00903201	MANETA FRENO DELANTERO FRONT BRAKE LEVER	1	
	09	32A	863712	ESPEJO RETROVISOR DERECHO RIGHT MIRROR	1	
	09	33A	863713	ESPEJO RETROVISOR IZQUIERDO LEFT MIRROR	1	
	10	04A	00H01002131	BOMBILLA H11 55W HEADLAMP BULB	2	
	10	04B	00H01004131	BOMBILLA H8 35W HEADLAMP BULB	2	ONLY ENGLAND/JAPAN
	10	14A	00H01001371	BOMBILLA POSICION 12V 2,3W REAR POSITION BULB	3	
	10	15A	00H01000681	BOMBILLA FRENO PILOTO 12V 16W STOP LIGHT BULB	1	
	10	24A	00H01701011	BOMBILLA INTERMITENTE 12V 10W NARANJA SIGNALS BULB	4	
	10	28A	00G03304401	BATERIA 12V 12AMP BATTERY	1	
	11	11A	864580	KIT COMPONENTES PASTILLAS FRENO DT SET OF FRONT BRAKE PADS	1	
	11	12A	863180	DISCO FRENO DELANTERO FRONT BRAKE DISC	1	
	12	04A	00H01304931	JUEGO PASTILLAS FRENO TRASERO SET OF REAR BRAKE PADS	1	
	12	13A	56391R	DISCO FRENO TRASERO REAR BRAKE DISC	1	



LAMINA / STAMPA / DIAGRAM / BILD / FEUILLE - 1

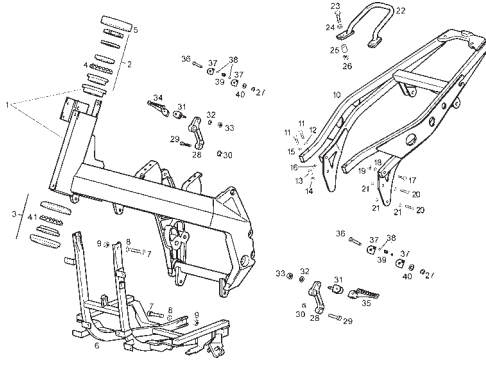

LAMINA / STAMPA / DIAGRAM / BILD / FEUILLE - 2

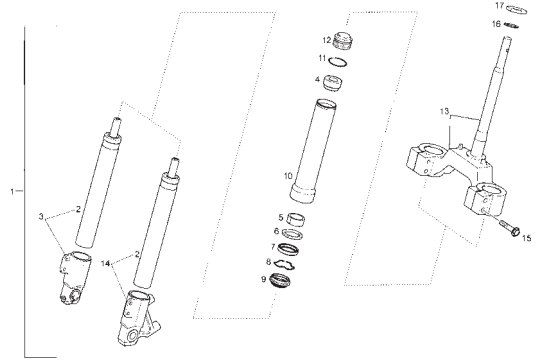

LAMINA / STAMPA / DIAGRAM / BILD / FEUILLE - 3

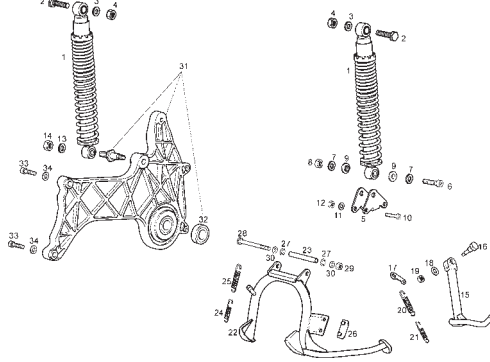

LAMINA / STAMPA / DIAGRAM / BILD / FEUILLE - 4

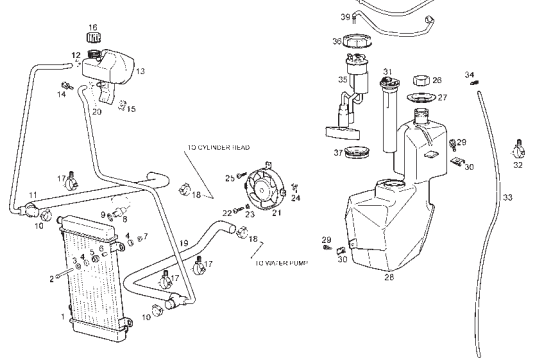

LAMINA / STAMPA / DIAGRAM / BILD / FEUILLE - 5

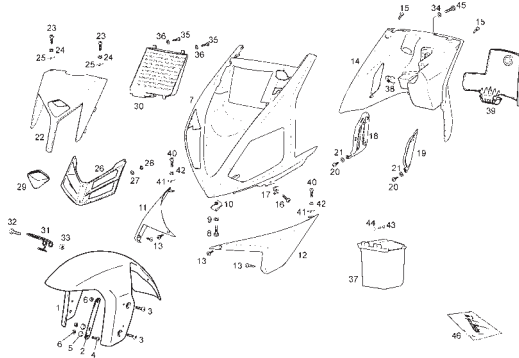

LAMINA / STAMPA / DIAGRAM / BILD / FEUILLE - 6

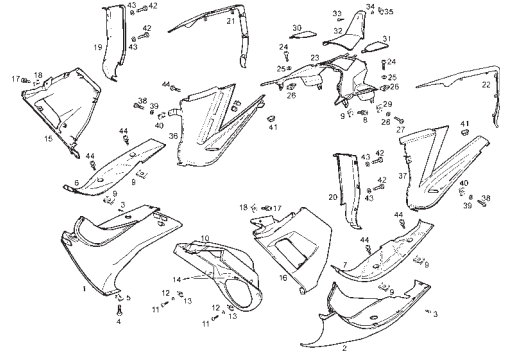

LAMINA / STAMPA / DIAGRAM / BILD / FEUILLE - 7

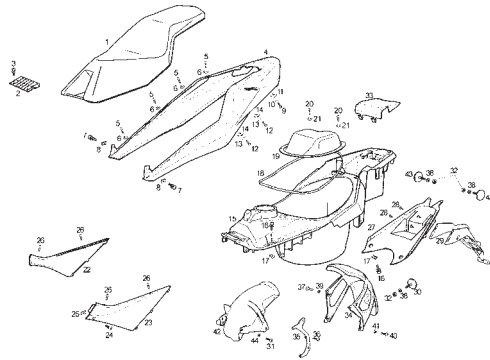

LAMINA / STAMPA / DIAGRAM / BILD / FEUILLE - 8

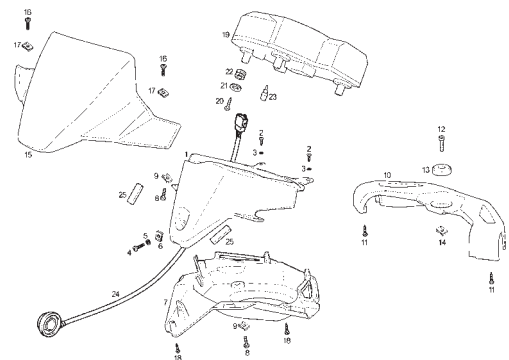

LAMINA / STAMPA / DIAGRAM / BILD / FEUILLE - 9

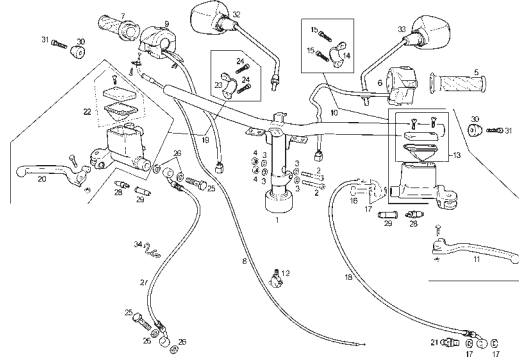

LAMINA / STAMPA / DIAGRAM / BILD / FEUILLE - 10

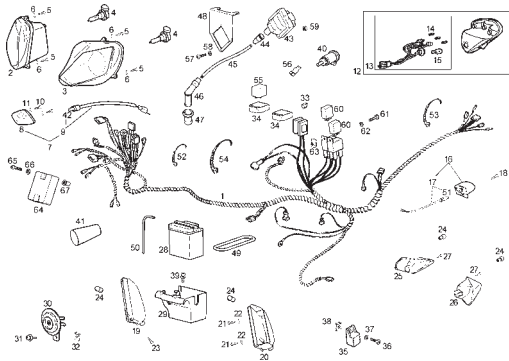

LAMINA / STAMPA / DIAGRAM / BILD / FEUILLE - 11

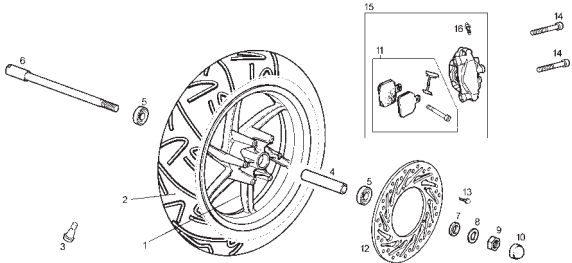

FWD

LAMINA / STAMPA / DIAGRAM / BILD / FEUILLE - 12

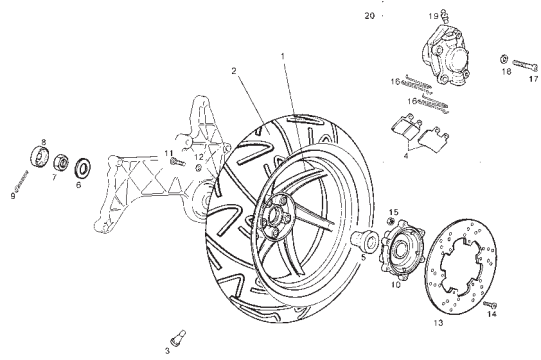

LAMINA / STAMPA / DIAGRAM / BILD / FEUILLE - 13

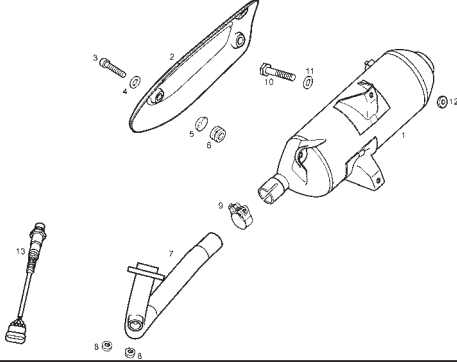

LAMINA / STAMPA / DIAGRAM / BILD / FEUILLE - 14

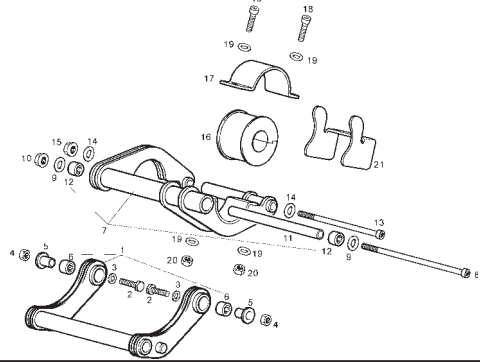

LAMINA / STAMPA / DIAGRAM / BILD / FEUILLE - 15

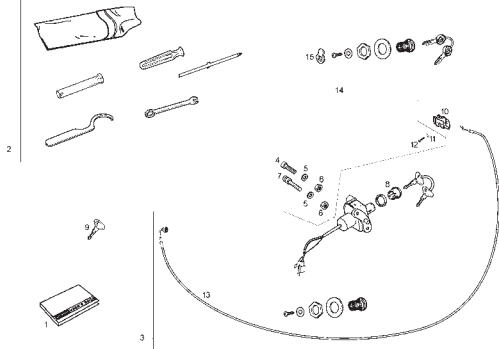

LAMINA / STAMPA / DIAGRAM / BILD / FEUILLE - 16

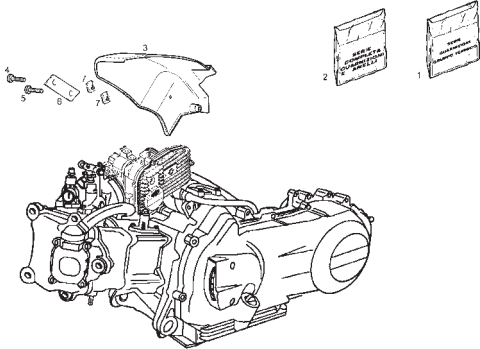

LAMINA / STAMPA / DIAGRAM / BILD / FEUILLE - 17

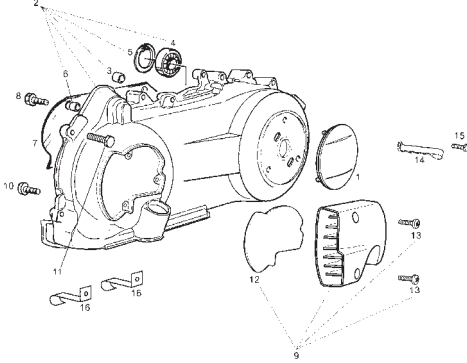

LAMINA / STAMPA / DIAGRAM / BILD / FEUILLE - 18

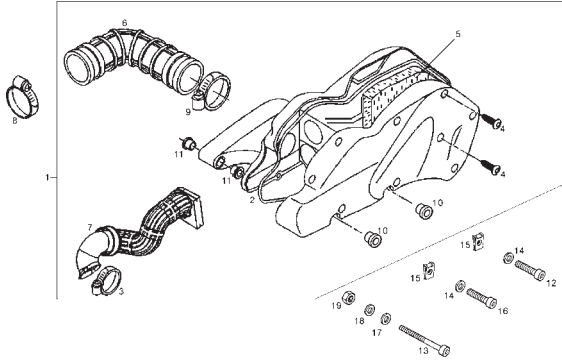

LAMINA / STAMPA / DIAGRAM / BILD / FEUILLE - 19

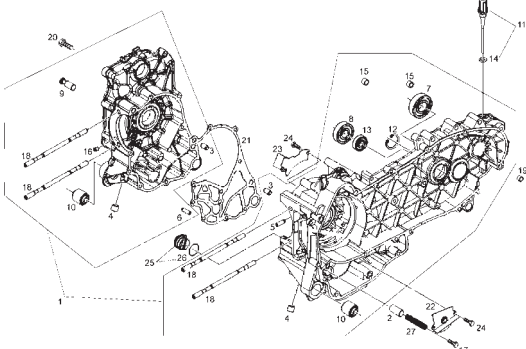

LAMINA / STAMPA / DIAGRAM / BILD / FEUILLE - 20

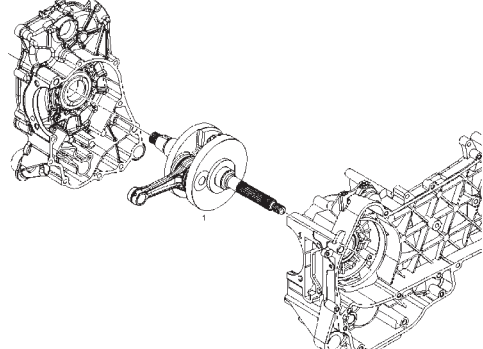

LAMINA / STAMPA / DIAGRAM / BILD / FEUILLE - 21

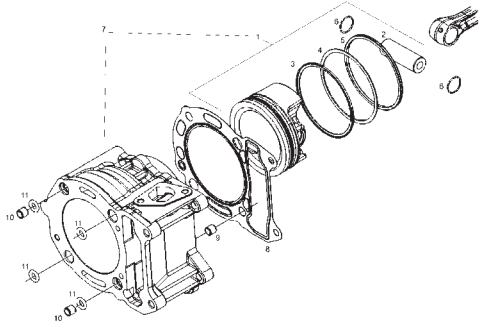

LAMINA / STAMPA / DIAGRAM / BILD / FEUILLE - 22

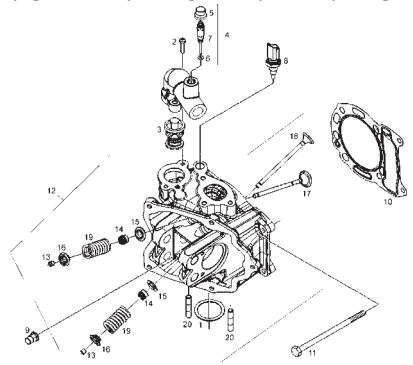

LAMINA / STAMPA / DIAGRAM / BILD / FEUILLE - 23

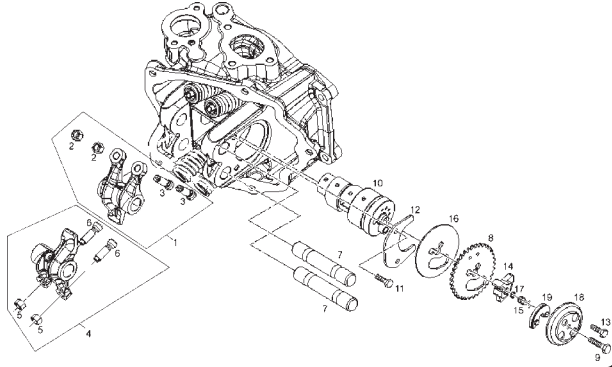

LAMINA / STAMPA / DIAGRAM / BILD / FEUILLE - 24

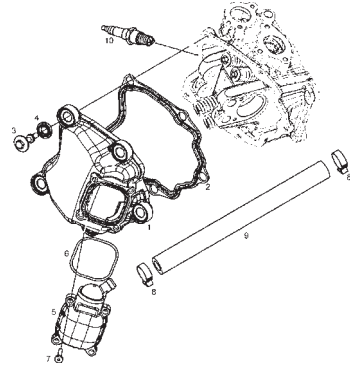

LAMINA / STAMPA / DIAGRAM / BILD / FEUILLE - 25

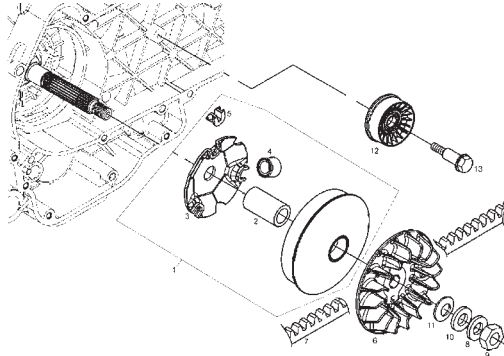

LAMINA / STAMPA / DIAGRAM / BILD / FEUILLE - 26

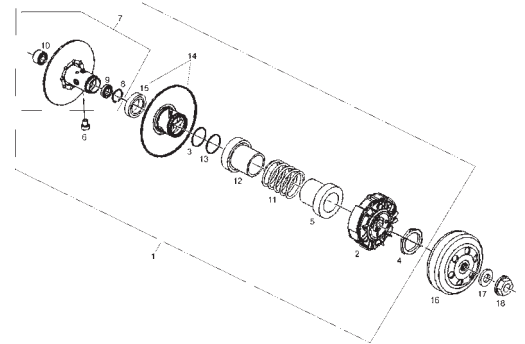

LAMINA / STAMPA / DIAGRAM / BILD / FEUILLE - 27

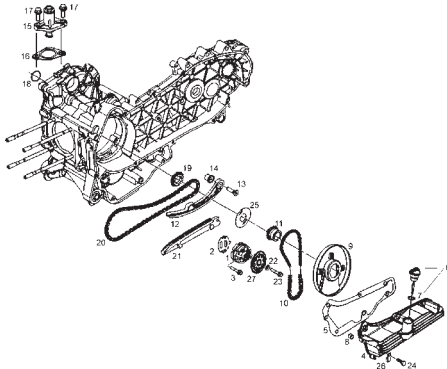

LAMINA / STAMPA / DIAGRAM / BILD / FEUILLE - 28

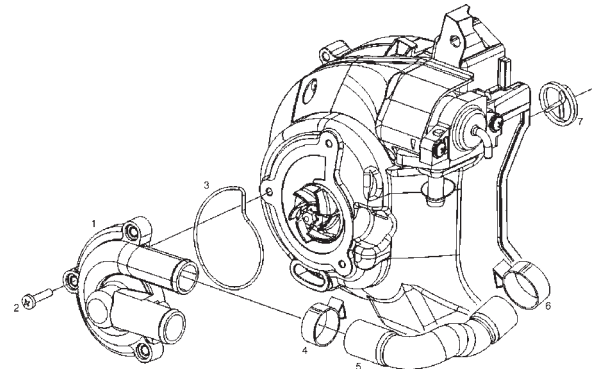

LAMINA / STAMPA / DIAGRAM / BILD / FEUILLE - 29

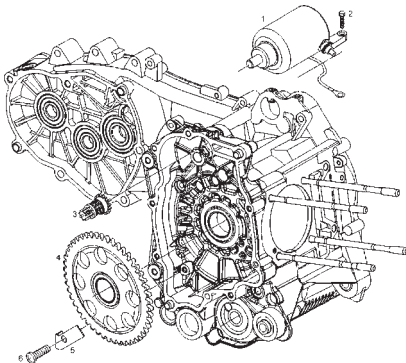

LAMINA / STAMPA / DIAGRAM / BILD / FEUILLE - 30

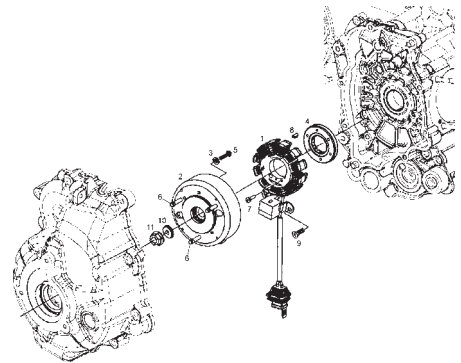

LAMINA / STAMPA / DIAGRAM / BILD / FEUILLE - 31

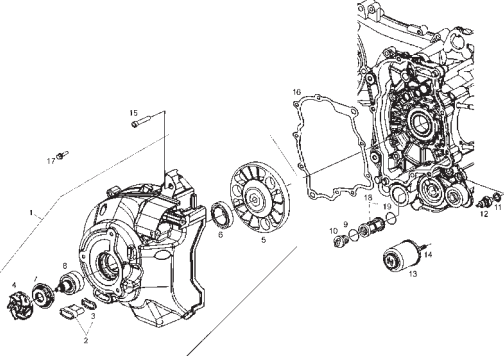

LAMINA / STAMPA / DIAGRAM / BILD / FEUILLE - 32

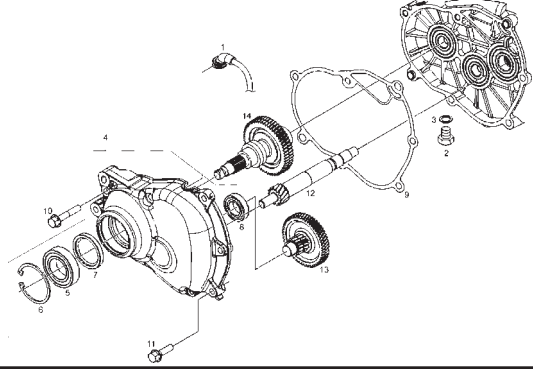

LAMINA / STAMPA / DIAGRAM / BILD / FEUILLE - 33

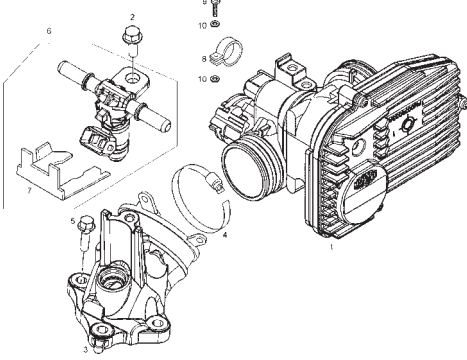

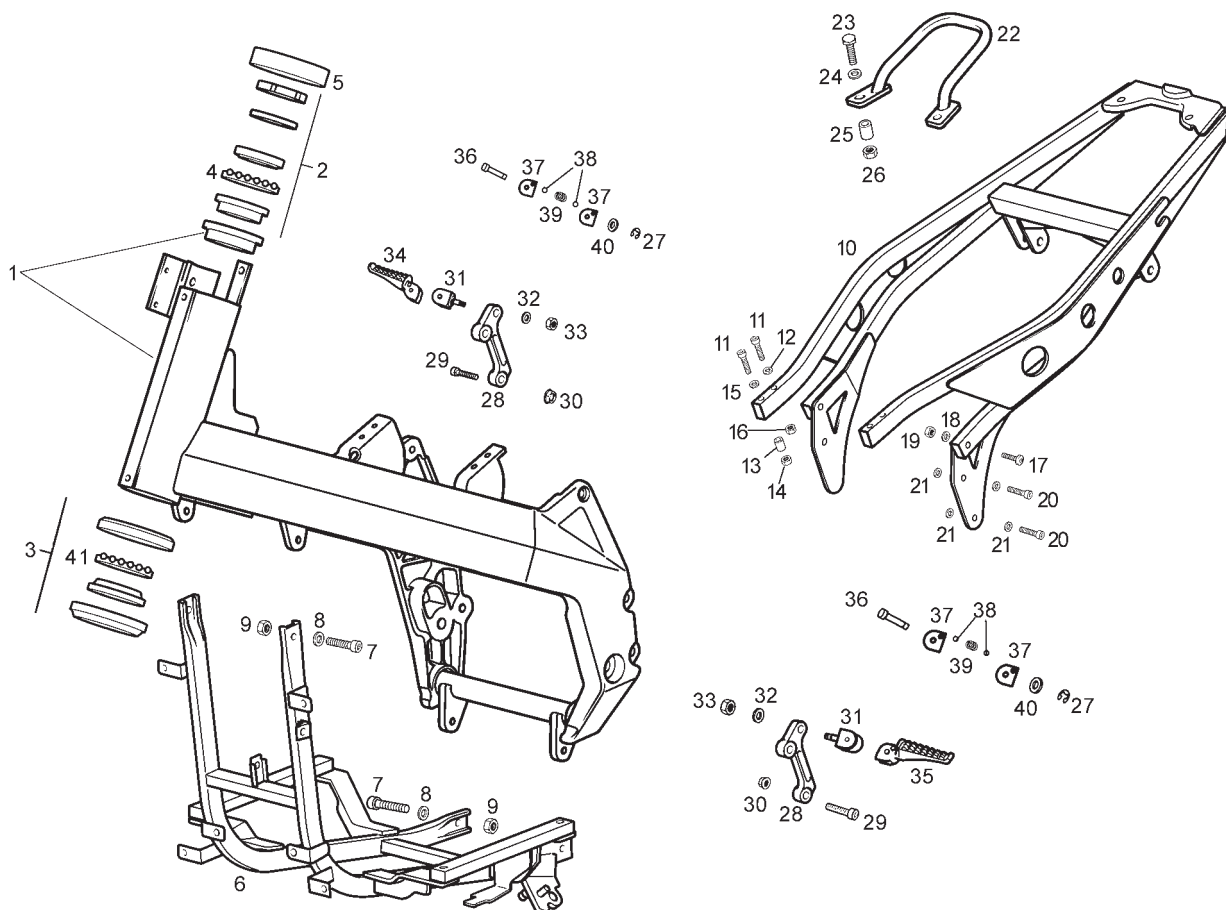

Fig.	Ver.	COD. KOD.	DESCRIPCIÓN DENOMINAZIONE NAME	BEZEICHNUNG DESIGNATION	MOD.	NOTAS NOTES NOTA MITSCHRIFT NOTES
01A		863558	CTO. CHASIS C/CAZOLETA TELAIO FRAME	RAHMEN SOUS ENSEMBLE CADRE	1 2	
02A		56002R	RODAMIENTOS DIRECCION SUPERIOR CUSCINETTO BEARING	KUGELLAGER ROULEMENT	1 2	
03A		56003R	RODAMIENTOS DIRECCION INFERIOR CUSCINETTO BEARING	KUGELLAGER ROULEMENT	1 2	
04A		077024	JAULA DE BOLAS GABBIA DI PALLE CAGE BALLS	SPERREN Sie BÄLLE EIN CAGE DES BALLES	1 2	
05A		00G00200761	GUARDAPOLVO DIRECCION PARAPOLVERE DUST SEAL	SCHMUTZBLECH CACHE-POUSSIÈRE	1 2	
06A		86338200W03	SUBCHASIS ANTERIOR TELAIO ANT. FRONT FRAME	VORDERER RAHMEN CADRE ANT	1 2	
07A		00000004825	TORNILLO C/ALLEN 8M125X25 VITE SCREW	SCHRAUBE VIS	1 2	
08A		00402080001	ARANDELA D8 RONDELLA WASHER	SCHEIBE RONDELLE	1 2	
09A		00023108000	TUERCA AUTOBLOCANTE 8M125 DADO NUT	MUTTER ECROU	1 2	
10A		86354600WNB	SUBCHASIS POSTERIOR TELAIO POST REAR FRAME	HINTERER RAHMEN CADRE ARRIERE	1 2	
11A		00004184500	TORNILLO C/ALLEN 8M125X45 VITE SCREW	SCHRAUBE VIS	1 2	

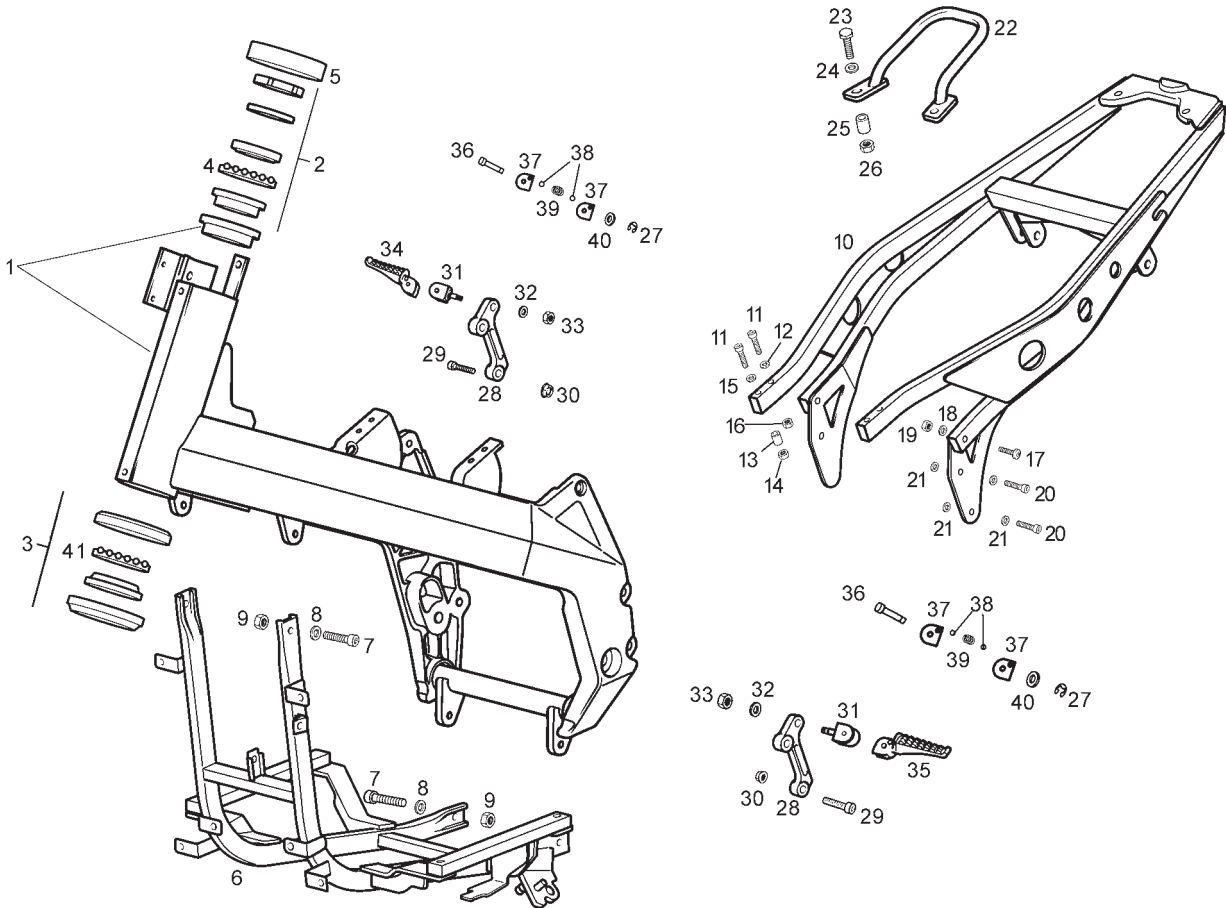

Fig.	Ver.	COD. KOD.	DESCRIPCIÓN DENOMINAZIONE NAME	BEZEICHNUNG DESIGNATION	MOD.	NOTAS NOTES NOTA MITSCHRIFT NOTES
12A		00452080002	ARANDELA PLANA D8 RONDELLA WASHER	SCHEIBE RONDELLE	1 2	
13A		00G01403411	CASQUILLO FIJACION GHIERA BUSH	DISTANZHULSE ENTRETOISE	1 2	
14A		00026008001	TUERCA EXAG C/BRIDA.8M125 DADO NUT	MUTTER ECROU	1 2	
15A		00442080002	ARANDELA D8 RONDELLA WASHER	SCHEIBE RONDELLE	1 2	
16A		00026008001	TUERCA EXAGONAL C/BRIDA DADO NUT	MUTTER ECROU	1 2	
17A		00004184001	TORNILLO C/ALLEN BAJ 8M125X40 VITE SCREW	SCHRAUBE VIS	1 2	
18A		00442080002	ARANDELA D8 RONDELLA WASHER	SCHEIBE RONDELLE	1 2	
19A		00023108000	TUERCA AUTOBLOCANTE 8M125 DADO NUT	MUTTER ECROU	1 2	
20A		00002082021	TORNILLO 8M125X20 VITE SCREW	SCHRAUBE VIS	1 2	
21A		00402080001	ARANDELA D8 RONDELLA WASHER	SCHEIBE RONDELLE	1 2	
22A		00G04902731	AGARRADERO SILLIN MANIGLIA HANDLE	HANDGRIFF POIGNÉE	1 2	

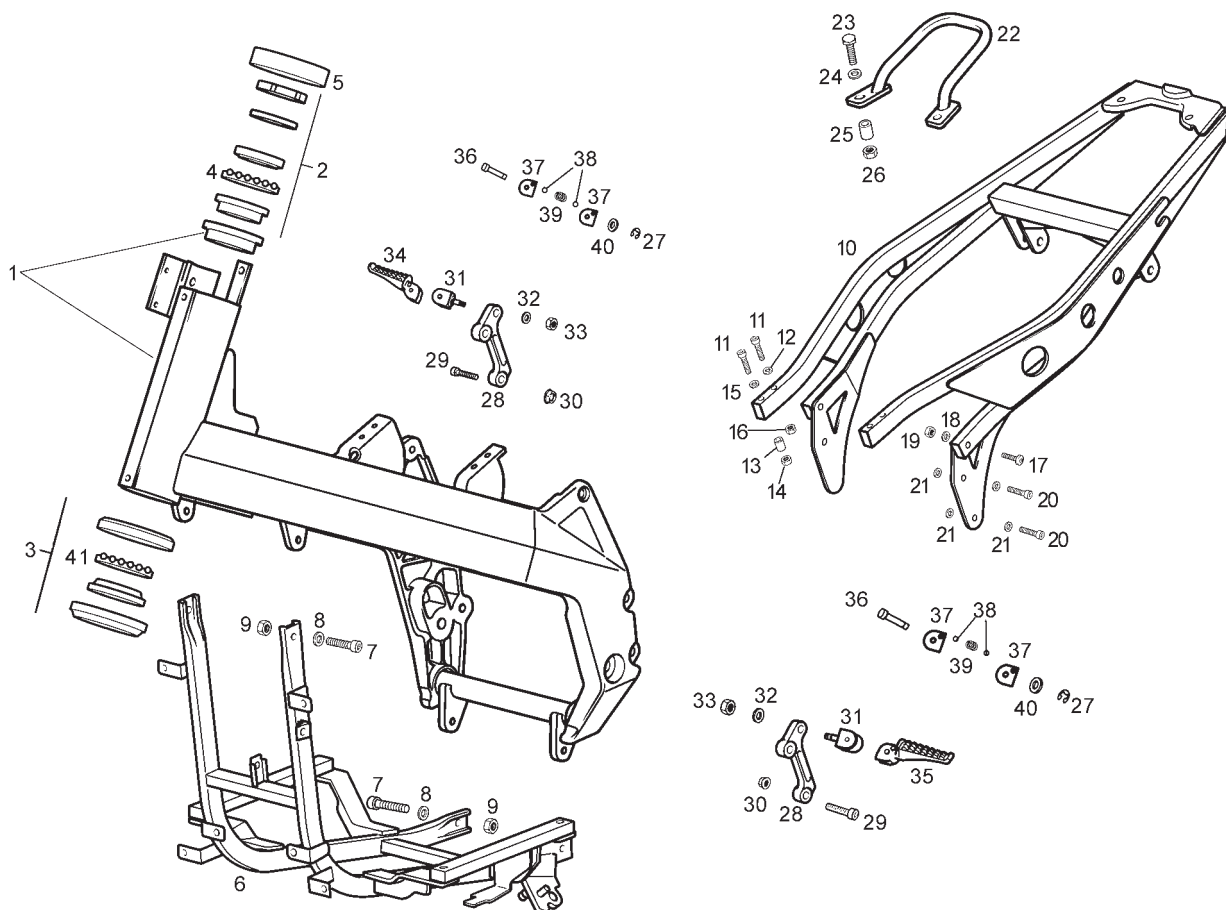

Fig.	Ver.	COD. KOD.	DESCRIPCIÓN DENOMINAZIONE NAME	BEZEICHNUNG DESIGNATION	MOD.	NOTAS NOTES NOTA MITSCHRIFT NOTES
23A		00000002825	TORNILLO C/EXAGONAL 8M125X25 VITE SCREW	SCHRAUBE VIS	1 2	
24A		00031008000	ARANDELA PLANA D8 RONDELLA WASHER	SCHEIBE RONDELLE	1 2	
25A		00G01403411	CASQUILLO FIJACION GHIERA BUSH	DISTANZHULSE ENTRETOISE	1 2	
26A		00000023080	TUERCA AUTOBLOCANTE 8M125 DADO NUT	MUTTER ECROU	1 2	
27A		00047030400	ANILLO SEGURIDAD EJES D4 ANELLO O'RING	RING ANNEAU	1 2	
28A		00G00100711	SOPORTE ESTRIBERA A CHASIS APPOGGIO FOOTREST	FUSSRASTER REPOSE PIED	1 2	
29A		00004283500	TORNILLO C/ALLEN 8M125X35 VITE SCREW	SCHRAUBE VIS	1 2	
30A		00023108000	TUERCA AUTOBLOCANTE 8M125 DADO NUT	MUTTER ECROU	1 2	
31A		00H02202301	SOPORTE ESTRIBERA SUPPORTO BRACKET	HALTERUNG SUPPORT	1 2	
32A		00402080001	ARANDELA D8 RONDELLA WASHER	SCHEIBE RONDELLE	1 2	
33A		00023108000	TUERCA AUTOBLOCANTE 8M125 DADO NUT	MUTTER ECROU	1 2	

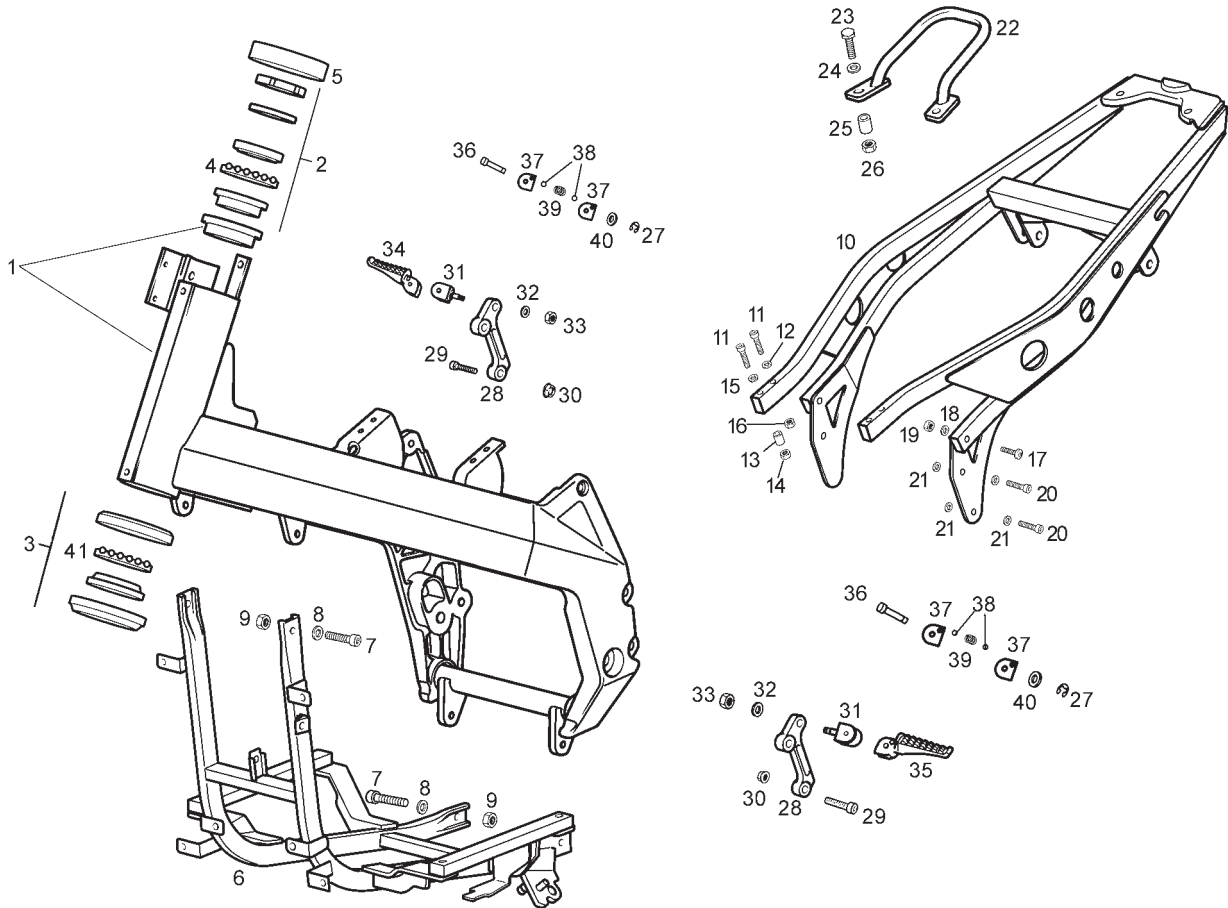

Fig.	Ver.	COD. KOD.	DESCRIPCIÓN DENOMINAZIONE NAME	BEZEICHNUNG DESIGNATION	MOD.	NOTAS NOTES NOTA MITSCHRIFT NOTES
34A		00H01507091	ESTRIBERA DERECHA APPOGGIO DX. RIGHT FOOTREST	FUSSRASTER RECHTS REPOSE PIED DROIT	1 2	
35A		00H01507451	ESTRIBERA IZQUIERDA APPOGGIO SX. LEFT FOOTREST	FUSSRASTER LINKS REPOSE PIED GAUCHE	1 2	
36A		00H04902311	EJE ARTICULACION ESTRIBERA ASSE AXLE	ACHSE AXE	1 2	
37A		00H04903401	SOPORTE BOLAS SUPPORTO BRACKET	HALTERUNG SUPPORT	1 2	
38A		00000061061	BOLA D6 PALLA BALL	KUGEL BILLE	1 2	
39A		00H04902291	MUELLE FIJACION ESTRIBERA PASAJERO MOLLA SPRING	FEDER RESSORT	1 2	
40A		00D01200171	ARANDELA RONDELLA WASHER	SCHEIBE RONDELLE	1 2	
41A		077023	JAULA DE BOLAS GABBIA DI PALLE CAGE BALLS	SPERREN Sie BÄLLE EIN CAGE DES BALLEES	1 2	

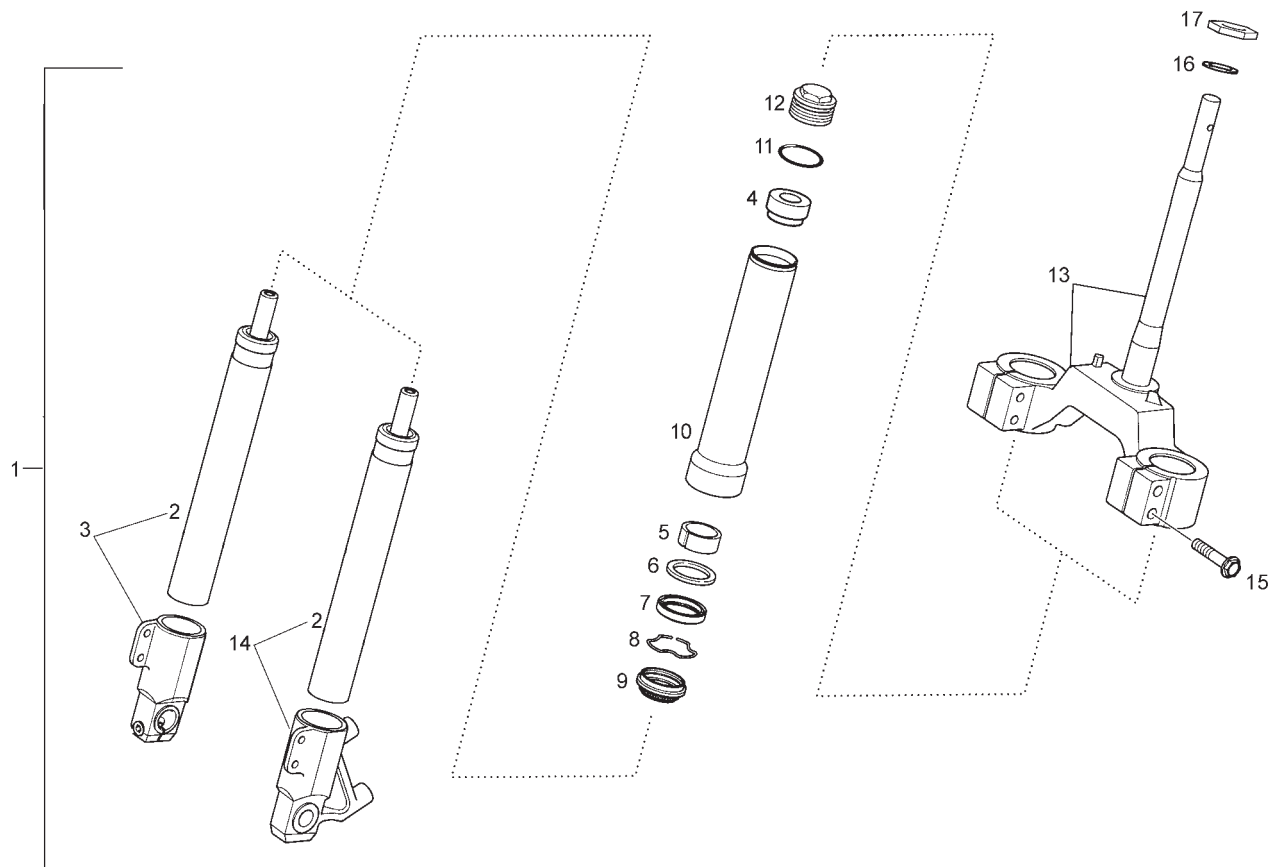

Fig.	Ver.	COD. KOD.	DESCRIPCIÓN DENOMINAZIONE NAME	BEZEICHNUNG DESIGNATION	MOD.	NOTAS NOTES NOTA MITSCHRIFT NOTES
01A		863186	CTO. HORQUILLA FORCELLA FRONT FORK ASSY	LENKUNGSGABEL FOURCHE AVANT	1 2	
02A		864545	SCTO HIDRAULICO IDRAULICO HYDRAULIC	HYDRAULISCH HYDRAULIQUE	1 2	
03A		864544	CTO HIDRAULICO C/PUNTERA DR IDRAULICO HYDRAULIC	HYDRAULISCH HYDRAULIQUE	1 2	
04A		864547	GOMA TOPE AMORTIGUACION FERMO STOPPER	ANSCHLAG BUTEE	1 2	
05A		864539	CASQUILLO GHIERA BUSH	DISTANZHULSE ENTRETOISE	1 2	
06A		864540	ARANDELA RONDELLA WASHER	SCHEIBE RONDELLE	1 2	
07A		864541	RETEN ACEITE GIUNTO TENUTA SEAL	DICHTRING JOINT	1 2	
08A		864542	ANILLO RETEN ACEITE ANELLO O'RING	RING ANNEAU	1 2	
09A		864543	GUARPOLVO RETEN ACEITE PARAPOLVERE DUSTGUARD	SCHMUTZBLECH CACHE-POUSSIERE	1 2	
10A		864538	PIERNA HORQUILLA GAMBA OUTER TUBE UNIT	BEIN JAMBE	1 2	
11A		864548	ANILLO TAPON PIERNA HORQUILLA ANELLO O'RING	RING ANNEAU	1 2	

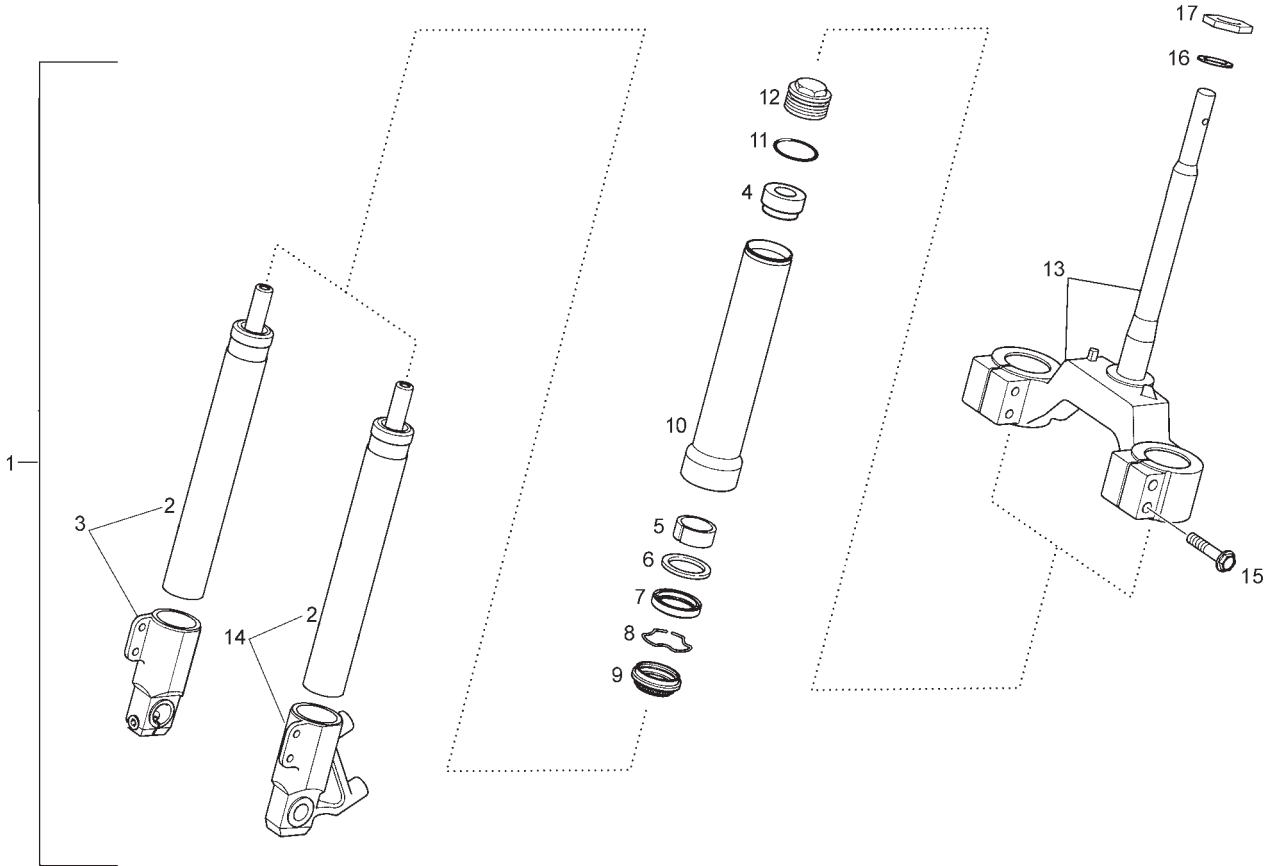

Fig.	Ver.	COD. KOD.	DESCRIPCIÓN DENOMINAZIONE NAME	BEZEICHNUNG DESIGNATION	MOD.	NOTAS NOTES NOTA MITSCHRIFT NOTES
12A		864549	TAPON PIERNA HORQUILLA TAPPO GAMBA FORCELLA PLUG UNIT	GABELSCHENKEL BOUCHON	1 2	
13A		864550	TIJA PLATINA SUBFUOTO PIASTRA LOWER TRIPLE CLAMP, W/PIN ASS	SATTELSTANGE-PLATTE PLATINE INF. AVEC PIVOT	1 2	
14A		864546	CTO HIDRAULICO C/PUNTERA IZQ IDRAULICO HYDRAULIC	HYDRAULISCH HYDRAULIQUE	1 2	
15A		864551	TORNILLO VITE SCREW	SCHRAUBE VIS	1 2	
16A		003751	ARANDELA RONDELLA WASHER	SCHEIBE RONDELLE	1 2	
17A		011109	CONTRATUERCA DIRECCION DADO NUT	MUTTER ECROU	1 2	

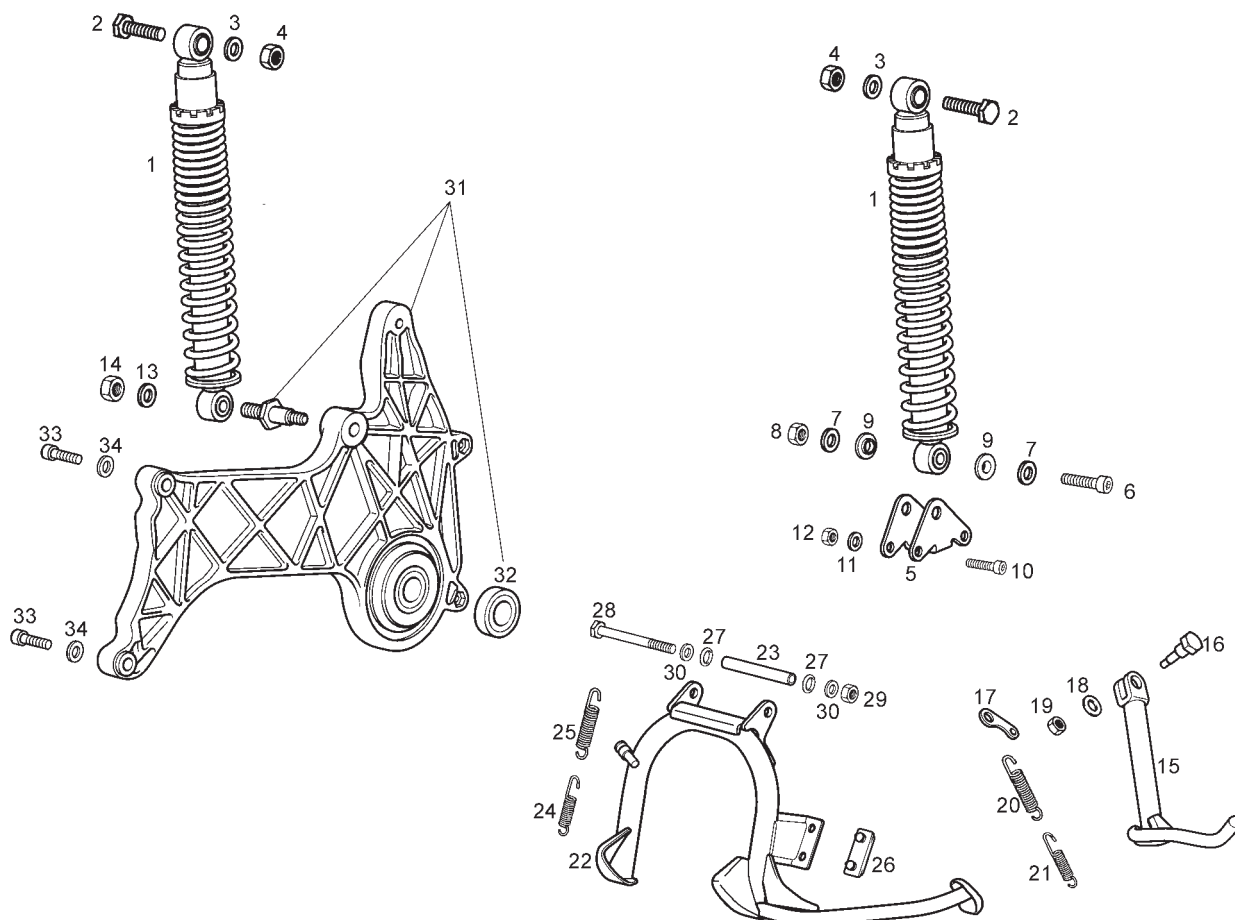

Fig.	Ver.	COD. KOD.	DESCRIPCIÓN DENOMINAZIONE NAME	BEZEICHUNG DESIGNATION	MOD.	NOTAS NOTES NOTA MITSCHRIFT NOTES
01A		863559	AMORTIGUADOR AMMORTIZZATORE SHOCK ABSORBER	AMORTISSEUR STOSSDAMPFER HINTEN	1 2	
02A		00006105000	TORNILLO EXAG.C/BRIDA 10M150X50 VITE SCREW	SCHRAUBE VIS	1 2	
03A		00402100001	ARANDELA D10 RONDELLA WASHER	SCHEIBE RONDELLE	1 2	
04A		00262100032	TUERCA 10M150 DADO NUT	MUTTER ECROU	1 2	
05A		949613	SOPORTE AMORTIGUADOR IZQUIERDO SUPPORTO BRACKET	HALTERUNG SUPPORT	1 2	
06A		00002105511	TORNILLO 10M150X55 VITE SCREW	SCHRAUBE VIS	1 2	
07A		00402100001	ARANDELA D10 RONDELLA WASHER	SCHEIBE RONDELLE	1 2	
08A		00262100032	TUERCA 10M150 DADO NUT	MUTTER ECROU	1 2	
09A		863560	CASQUILLO AMORTIGUADOR GHIERA BUSH	DISTANZHULSE ENTRETOISE	1 2	
10A		00000004850	TORNILLO C/ALLEN 8M125X50 VITE SCREW	SCHRAUBE VIS	1 2	

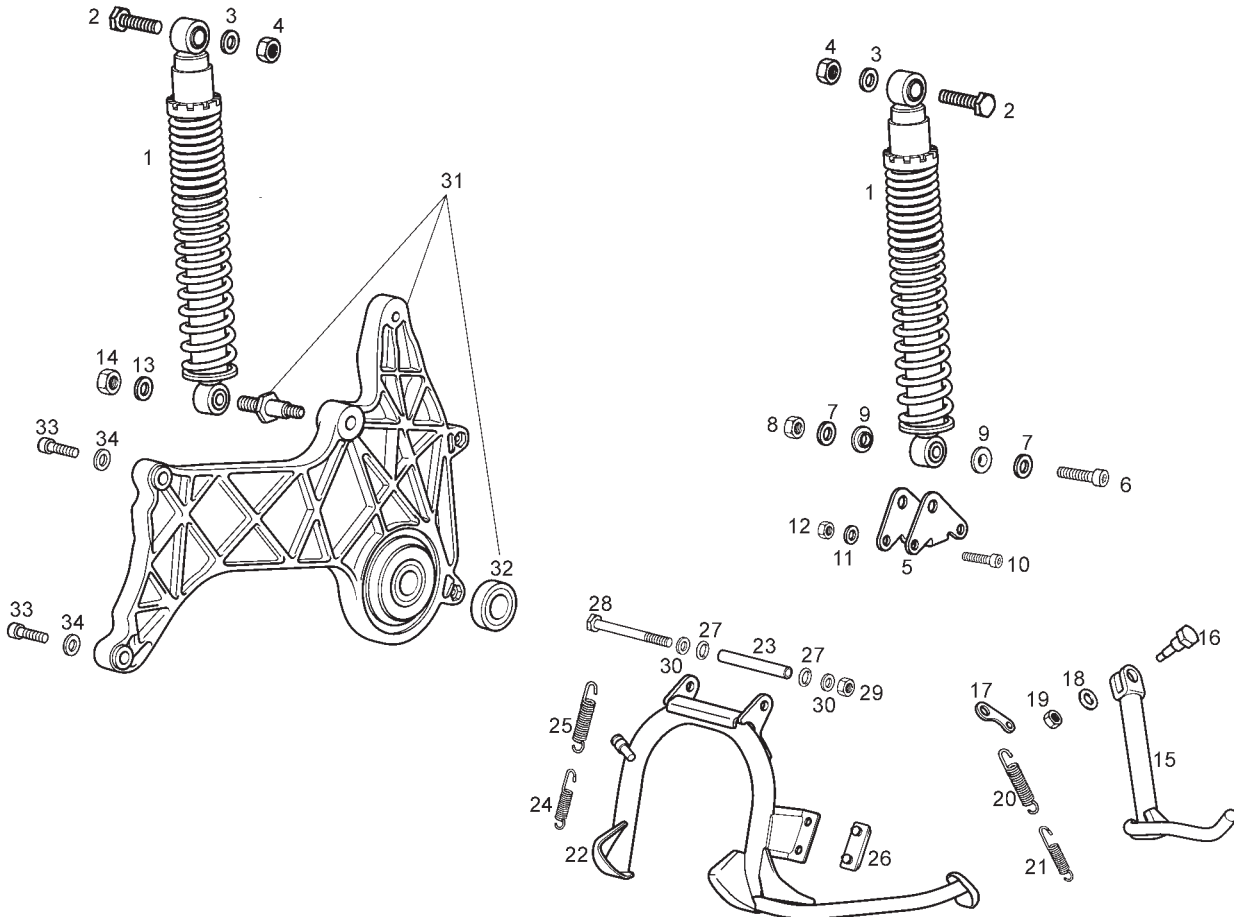

Fig.	Ver.	COD. KOD.	DESCRIPCIÓN DENOMINAZIONE NAME	BEZEICHNUNG DESIGNATION	MOD.	NOTAS NOTES NOTA MITSCHRIFT NOTES
11A		00402080001	ARANDELA D8 RONDELLA WASHER	SCHEIBE RONDELLE	1 2	
12A		00026008001	TUERCA EXAG.C/BRIDA 8M125 DADO NUT	MUTTER ECROU	1 2	
13A		00402100001	ARANDELA D10 RONDELLA WASHER	SCHEIBE RONDELLE	1 2	
14A		00262100032	TUERCA 10M150 DADO NUT	MUTTER ECROU	1 2	
15A		86369100WNB	PATA CABALLETE ZAMPA CAVALETO SIDE STAN	SEITENSTANDER BEQUILLE LATERALE	1 2	
16A		00H00805072	EJE GIRO PATA CABALLETE ASSE AXLE	ACHSE ESSIEU	1 2	
17A		00H00800421	PLACA RETORNO CABALLETE PIASTRINA RITORNO CAVALLETO G SPRING KIK-STAND SUPPORT	PLATTE F. GESTELLRUCKFUHRU SUPPORT RESSORT DE BEQUILLE	1 2	
18A		00402080001	ARANDELA D8 RONDELLA WASHER	SCHEIBE RONDELLE	1 2	
19A		00023108000	TUERCA AUTOBLOCANTE 8M125 DADO NUT	MUTTER ECROU	1 2	
20A		863168	MUELLE EXTERIOR MOLLA SPRING	FEDER RESSORT	1 2	

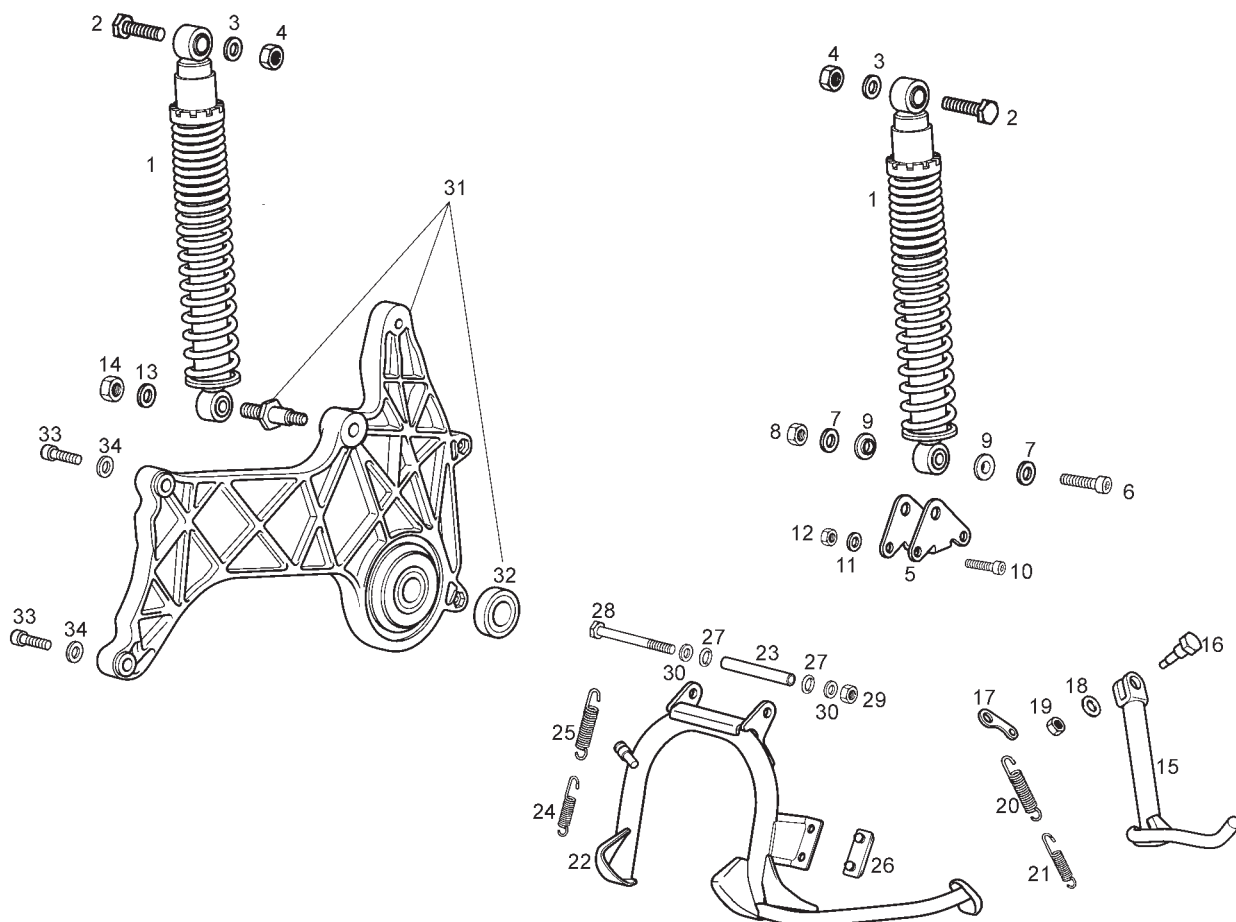

Fig.	Ver.	COD. KOD.	DESCRIPCIÓN DENOMINAZIONE NAME	BEZEICHUNG DESIGNATION	MOD.	NOTAS NOTES NOTA MITSCHRIFT NOTES
21A		863169	MUELLE INTERIOR MOLLA SPRING	FEDER RESSORT	1 2	
22A		647246	CABALLETE CENTRAL CAVALLETTO STAND	STÄNDER BÉQUILLE	1 2	
23A		582298	TUBO SEPARADOR CABALLETE TUBO SEPARAZIONE SEPARATOR TUB	DISTANZROHR TUBE SEPARATION	1 2	
24A		582850	MUELLE CABALLETE INTERIOR MOLLA SPRING	FEDER RESSORT	1 2	
25A		582851	MUELLE CABALLETE EXTERIOR MOLLA SPRING	FEDER RESSORT	1 2	
26A		581560	SILENT-BLOCK CABALLETE CENTRAL FERMO STOPPER	ANSCHLAG BUTEÉ	1 2	
27A		273754	ANILLO TORICO ANELLO O'RING	RING ANNEAU	1 2	
28A		030115	TORNILLO EXAGONAL 10M150X130 VITE SCREW	SCHRAUBE VIS	1 2	
29A		232108	TUERCA EXAGONAL 10M150 DADO NUT	MUTTER ECROU	1 2	
30A		00402100001	ARANDELA D10 RONDELLA WASHER	SCHEIBE RONDELLE	1 2	

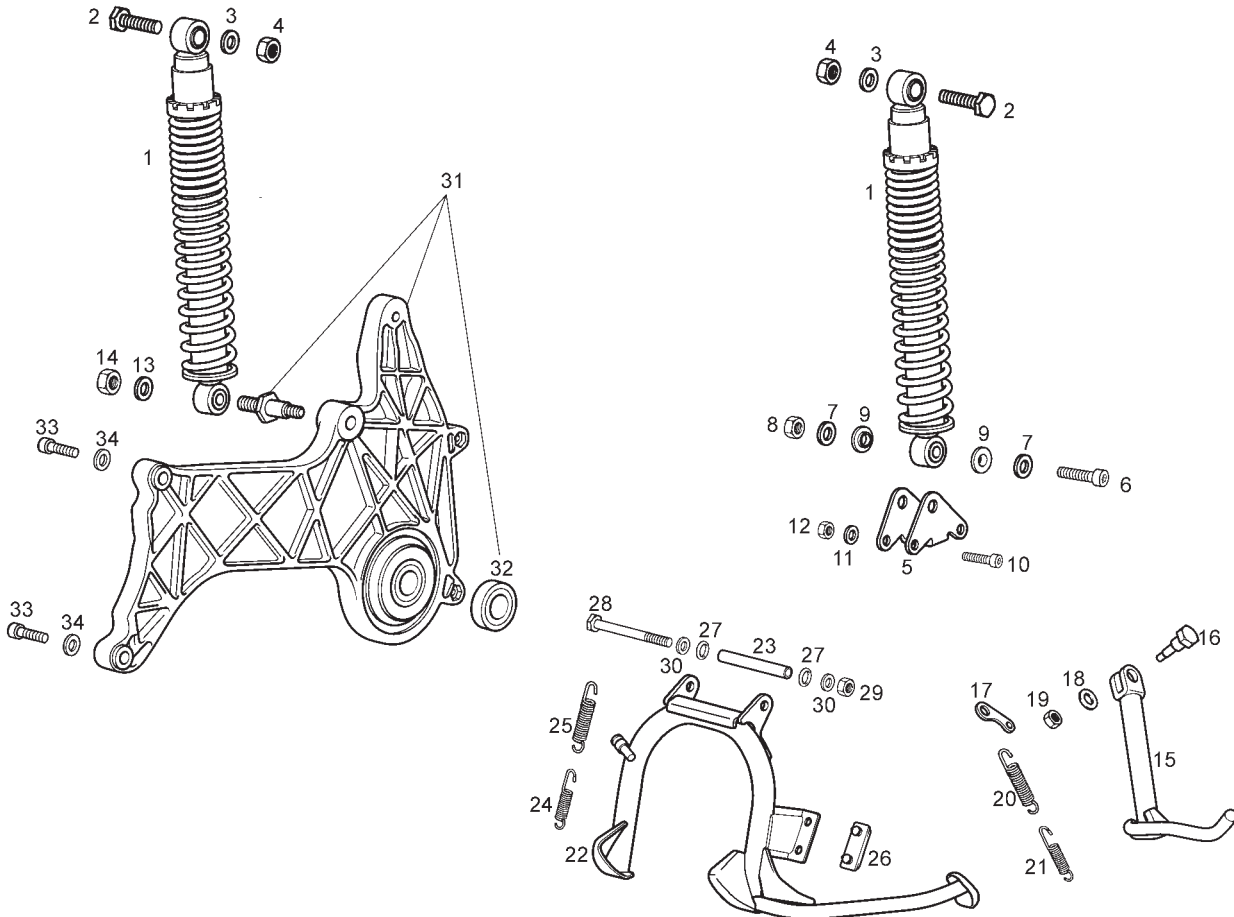

Fig.	Ver.	COD. KOD.	DESCRIPCIÓN DENOMINAZIONE NAME	BEZEICHUNG DESIGNATION	MOD.	NOTAS NOTES NOTA MITSCHRIFT NOTES
31A		863758	CTO.BRAZO SUSPENSION SUBRIBALTABILE SWING ARM SUB-ASSY	SCHWINGENACHSE BRAS OSCILLANT	1 2	
32A		82545R	COJINETE BRAZO SUSPENSION CUSCINETTO BEARING	LAGER ROULEMENT	1 2	
33A		00002084514	TORNILLO 8M125X45 VITE SCREW	SCHRAUBE VIS	1 2	
34A		00402080001	ARANDELA D8 RONDELLA WASHER	SCHEIBE RONDELLE	1 2	

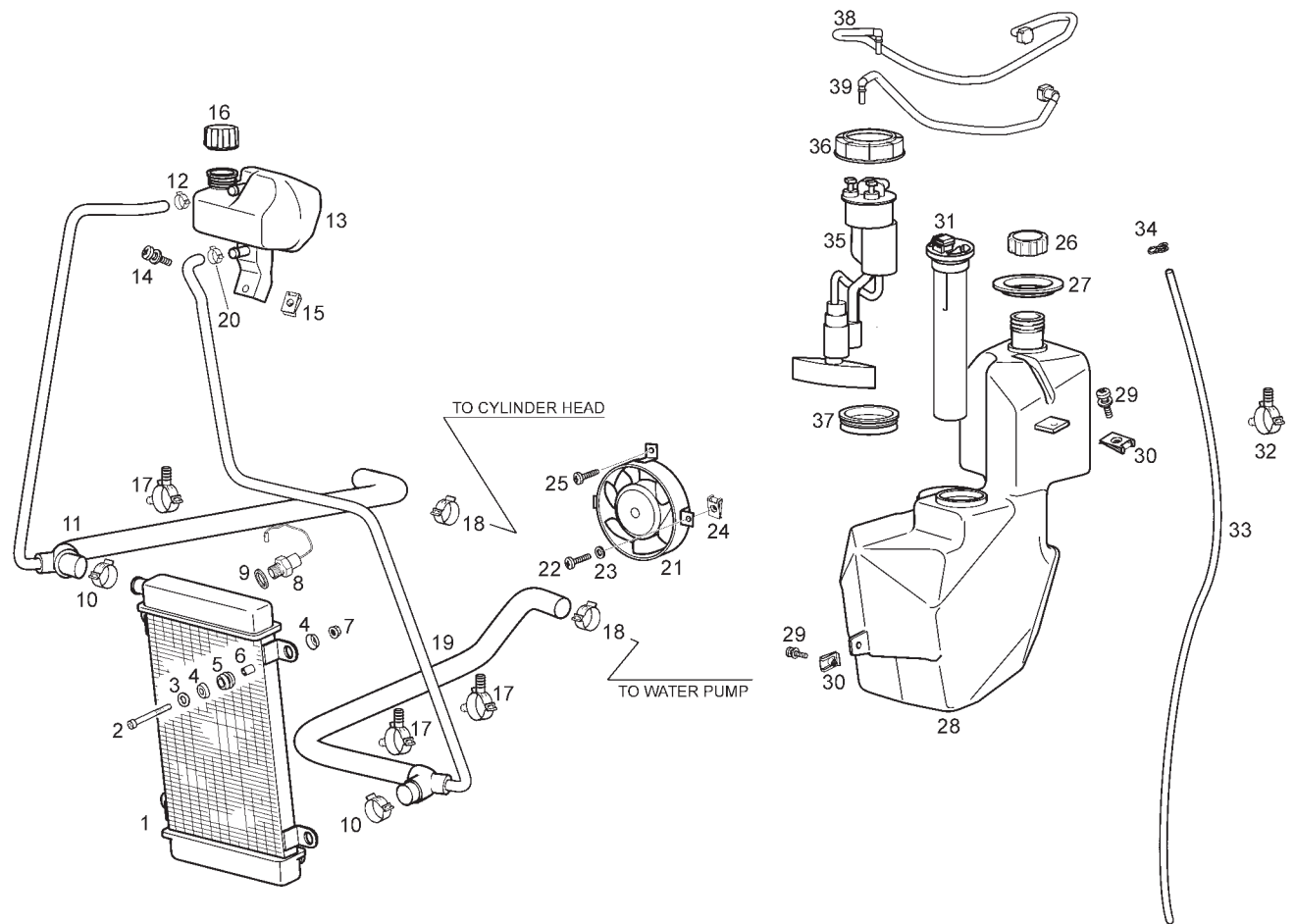

Fig.	Ver.	COD. KOD.	DESCRIPCIÓN DENOMINAZIONE NAME	BEZEICHNUNG DESIGNATION	MOD.	NOTAS NOTES NOTA MITSCHRIFT NOTES
01A		00G03805011	RADIADOR RADIATORE RADIATOR	RADIATOR RADIATEUR	1 2	
02A		00002062511	TORNILLO 6M100X25 VITE SCREW	SCHRAUBE VIS	1 2	
03A		00402060001	ARANDELA D6 RONDELLA WASHER	SCHEIBE RONDELLE	1 2	
04A		00D01500552	CAZOLETA SCADELLINO FISSAGGIO HOUSING	ABDECKSCHEIBE CUVETTE	1 2	
05A		00008915020	PROTECCION CABLES PROTEZIONE CAVI RUBBER,CABLE PROTECTOR	GUMMI PASSE-CABLE	1 2	
06A		00D01500471	CASQUILLO GHIERA BUSH	DISTANZHULSE ENTRETOISE	1 2	
07A		00000023060	TUERCA AUTOBLOCANTE 6M100 DADO NUT	MUTTER ECROU	1 2	
08A		584715	TERMOCONTACTO RADIADOR TERMOCONTATTO TERMOCONTACT	THERMOKONTAKT TERMOCONTATTO	1 2	
09A		168077	JUNTA TERMOCONTACTO GUARNIZIONE GASKET	DICHTUNG JOINT	1 2	
10A		00D03400521	ABRAZADERA FASCETTA CLAMP	SHELLE COLLIER	1 2	
11A		863813	TUBO CULATA RADIADOR TUBO TUYAU PIPE	ROHR TUYAU	1 2	

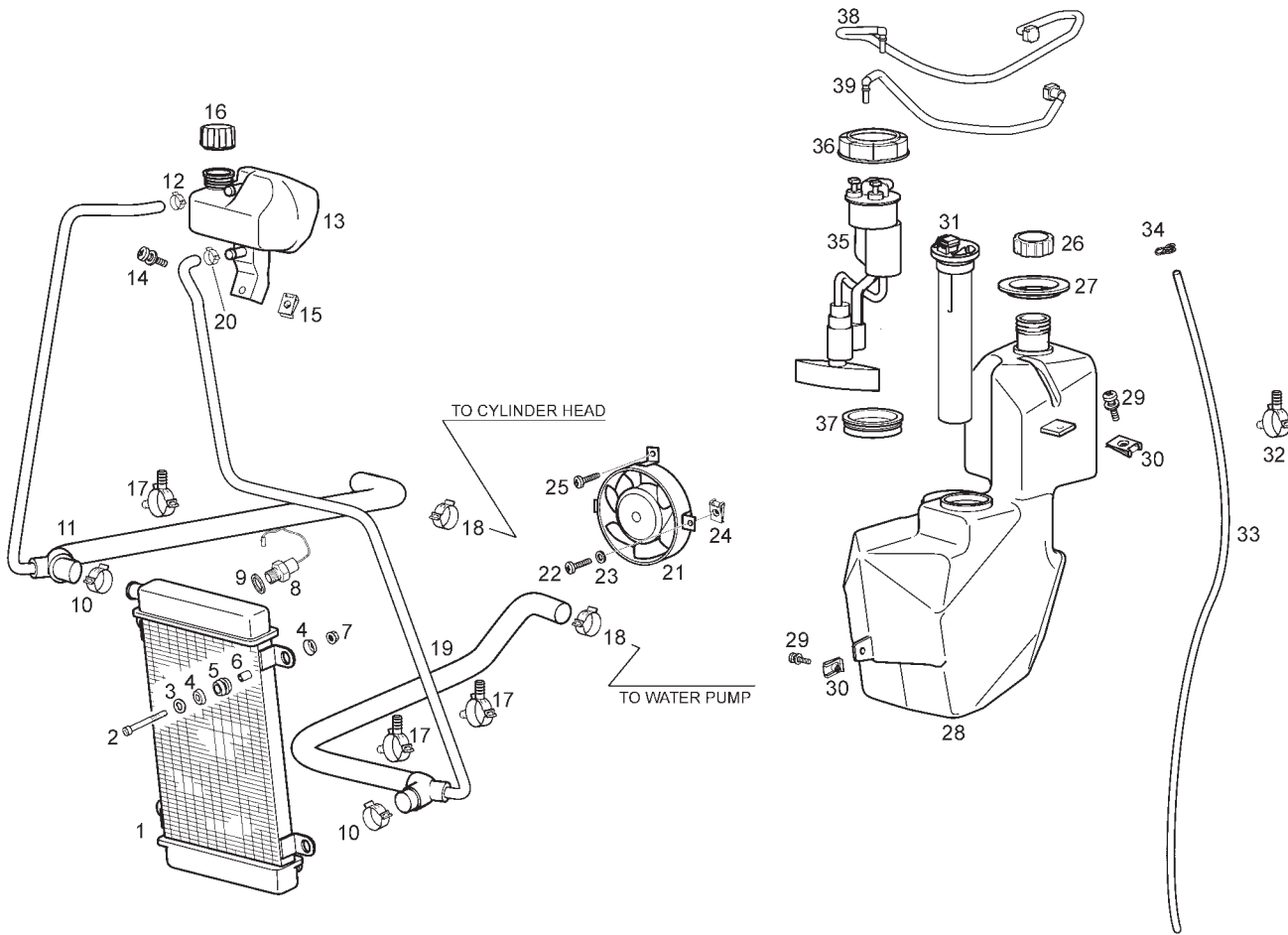

Fig.	Ver.	COD. KOD.	DESCRIPCIÓN DENOMINAZIONE NAME	BEZEICHNUNG DESIGNATION	MOD.	NOTAS NOTES NOTA MITSCHRIFT NOTES
12A		00G03801701	ABRAZADERA NORMA COBRA 13/8 W4 FASCETTA CLAMP	SHELLE COLLIER	1 2	
13A		00G03803501	DEPOSITO EXPANSOR SERBATOIO ACQUA RADIATORE WATER TANK	WASSERBEHALTER VASE DIEXPANSION	1 2	
14A		00H05900021	SCTO.TORNILLO 6M100X16 VITE SCREW	SCHRAUBE VIS	1 2	
15A		00D01501371	TUERCA FIJACION D6 DADO NUT	MUTTER ECROU	1 2	
16A		00G03800471	TAPON DEPOSITO AGUA TAPPO SERBATOIO WATER RESERVOIR CAP	KUEHLERDECKEL BOUCHON DE RESERVOIR D,EAU	1 2	
17A		00G03802091	ABRAZADERA MANGUITO AGUA D25,4 FASCETTA CLAMP	SHELLE COLLIER	1 2	
18A		00D03400521	ABRAZADERA FASCETTA CLAMP	SHELLE COLLIER	1 2	
19A		00G03802041	TUBO RADIADOR-MOTOR TUBO PIPE	ROHR TUYAU	1 2	
20A		00H03806091	ABRAZADERA NORMA COBRA 16/8 W4 FASCETTA CLAMP	SHELLE COLLIER	1 2	
21A		00G05700551	ELECTROVENTILADOR ELETTOVENTOLA ELECTRIC FAN	ELECTRISCHES GEBLASE ELECTROVENTILATEUR	1 2	
22A		00012151500	TORNILLO C/REDONDA CRUZ 5M80X16 VITE SCREW	SCHRAUBE VIS	1 2	

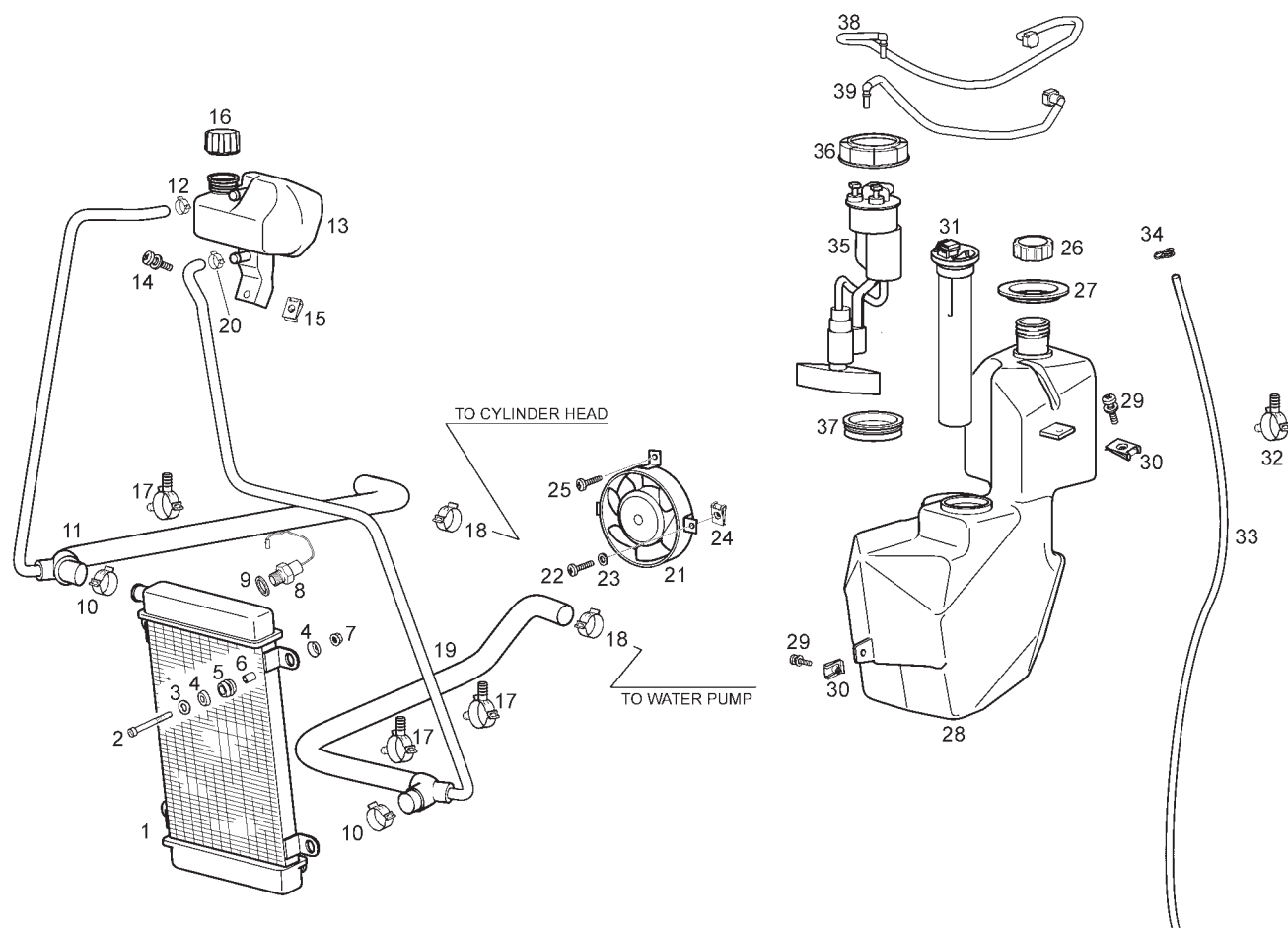

Fig.	Ver.	COD. KOD.	DESCRIPCIÓN DENOMINAZIONE NAME	BEZEICHNUNG DESIGNATION	MOD.	NOTAS NOTES NOTA MITSCHRIFT NOTES
23A		00000031050	ARANDELA PLANA D5 RONDELLA WASHER	SCHEIBE RONDELLE	1 2	
24A		00H01500691	TUERCA FIJACION D5 DADO NUT	MUTTER ECROU	1 2	
25A		00011141300	TORNILLO AUTOROSCANTE 4,8X13 VITE SCREW	SCHRAUBE VIS	1 2	
26A		00G00402131	TAPON DEPOSITO GASOLINA TAPPO SERBATOIO BENZINA FUEL TANK CAP	TANKVERSCHLUSS ENS. BOUCHON RESERV. ESSENCE V.B	1 2	
27A		00G06200051	JUNTA BOCA DEPOSITO GASOLINA GUARNIZIONE GASKET	FUGUNS JOINT	1 2	
28A		863762	DEPOSITO GASOLINA SERBATOIO BENZINA FUEL TANK	BENZINTANK RESERVOIR ESSENCE	1 2	
29A		00D05900081	SCTO TORNILLO 6M100X16 VITE SCREW	SCHRAUBE VIS	1 2	
30A		00D01501371	TUERCA FIJACION D6 DADO NUT	MUTTER ECROU	1 2	
31A		CM025707	CTO NIVEL GASOLINA GALLEGGIANTE BENZINA FUEL LEVEL FLOAT ASSY	BENZINSTANDGEBER FLOTTEUR ESSENCE	1 2	
32A		00G03802091	ABRAZADERA MANGUITO AGUA D25,4 FASCETTA CLAMP	SHELLE COLLIER	1 2	
33A		00G03702461	TUBO DRENAJE DEPOSITO TUBO PIPE	ROHR TUYAU	1 2	

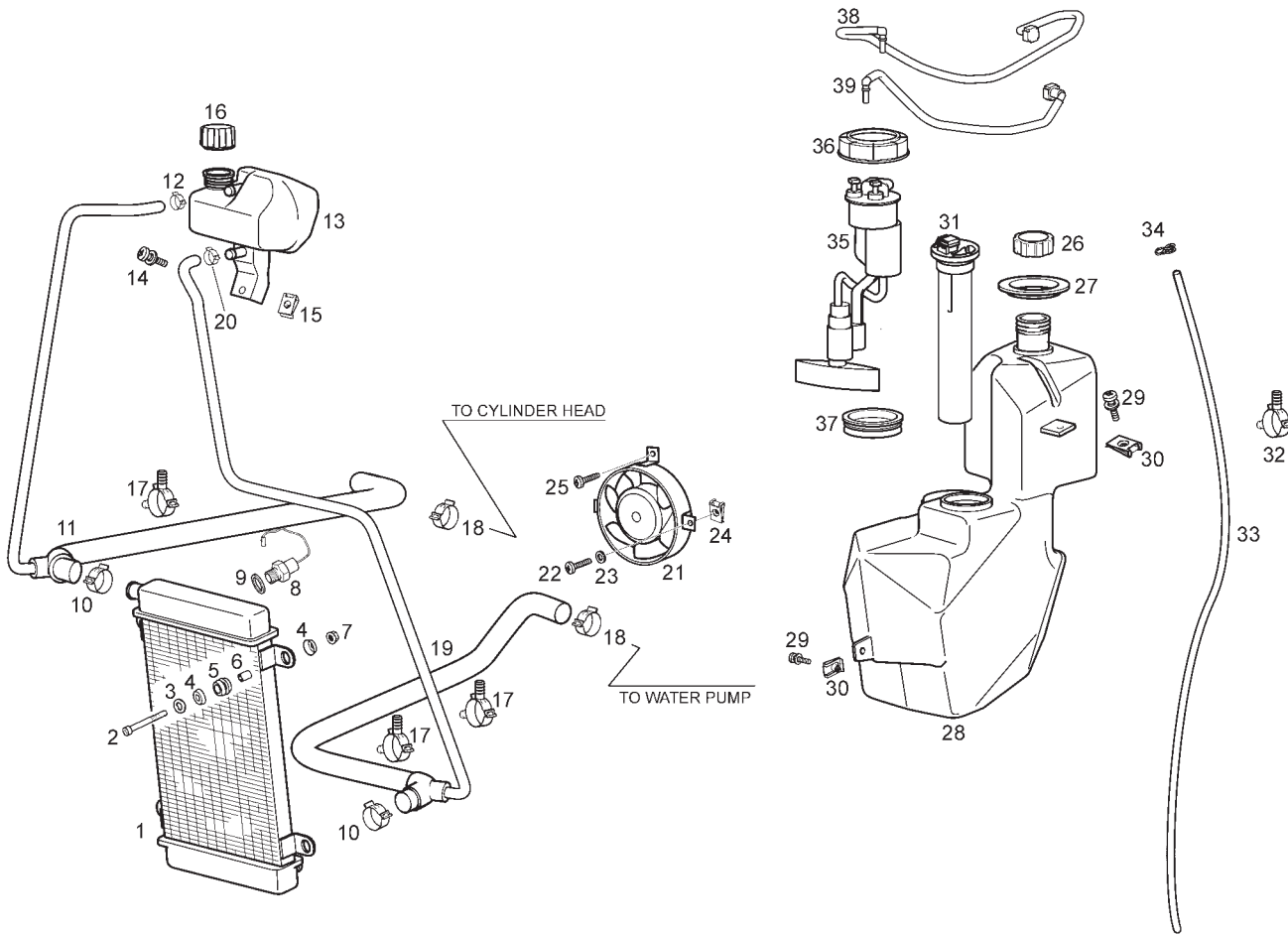

Fig.	Ver.	COD. KOD.	DESCRIPCIÓN DENOMINAZIONE NAME	BEZEICHNUNG DESIGNATION	MOD.	NOTAS NOTES NOTA MITSCHRIFT NOTES
34A		00D03700131	ABRAZADERA ELASTICA 9,8 - 10,4 FASCETTA CLAMP	SHELLE COLLIER	1 2	
35A		639150	BOMBA GASOLINA POMPA BENZINA FUEL PUMP	BENZINEPUMPE POMPE A ESSENCE	1 2	
36A		576546	TUERCA FIJACION BOMBA DADO NUT	MUTTER ECROU	1 2	
37A		576542	JUNTA ANCLAJE BOMBA GUARNIZIONE PACKING	DICHTUNG JOINT	1 2	
38A		863796	CTO TUBO ALIMENTACION GASOLINA TUBO PIPE	ROHR TUYAU	1 2	
39A		863798	CTO TUBO RETORNO GASOLINA TUBO PIPE	ROHR TUYAU	1 2	

**PIEZAS SIN CALCAS  
PARTS WITHOUT DECALS**

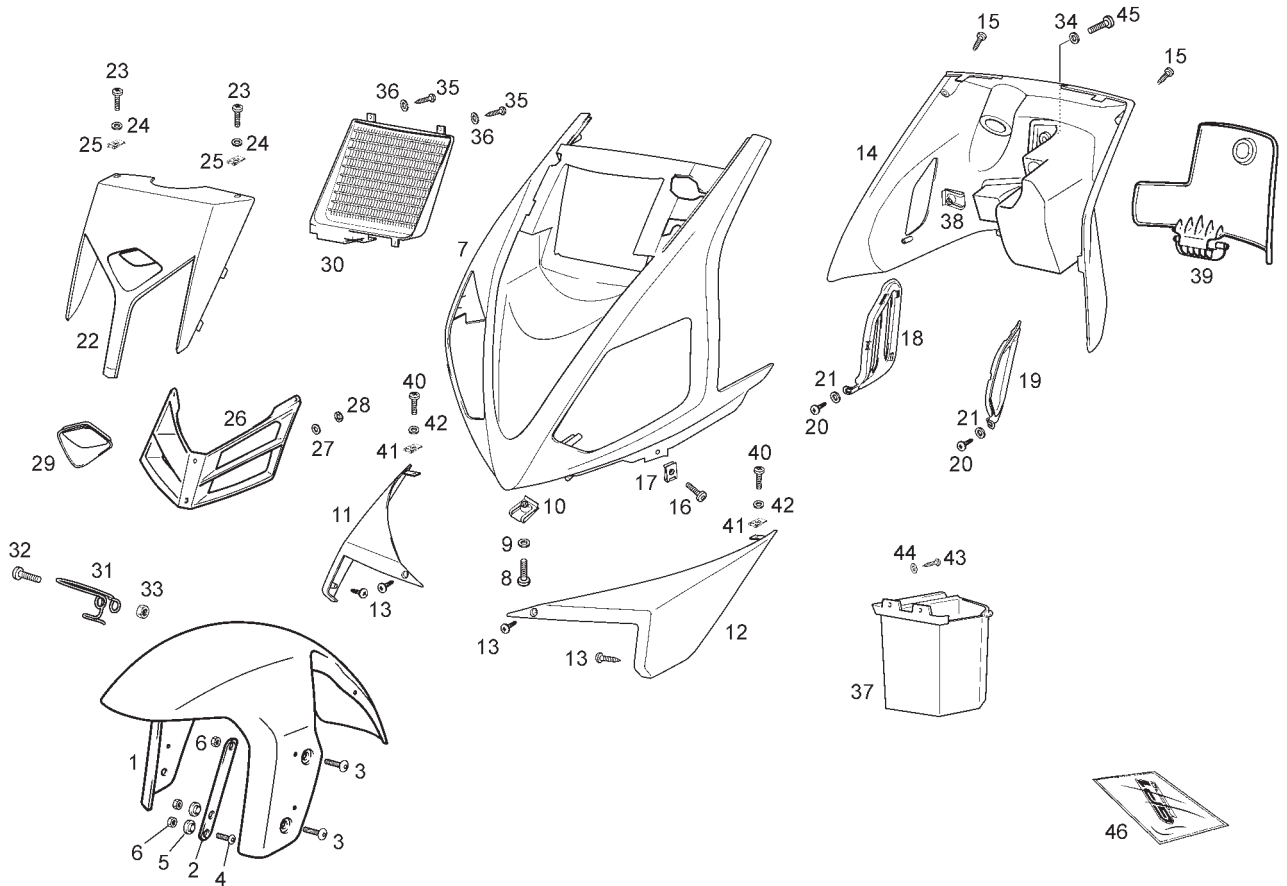
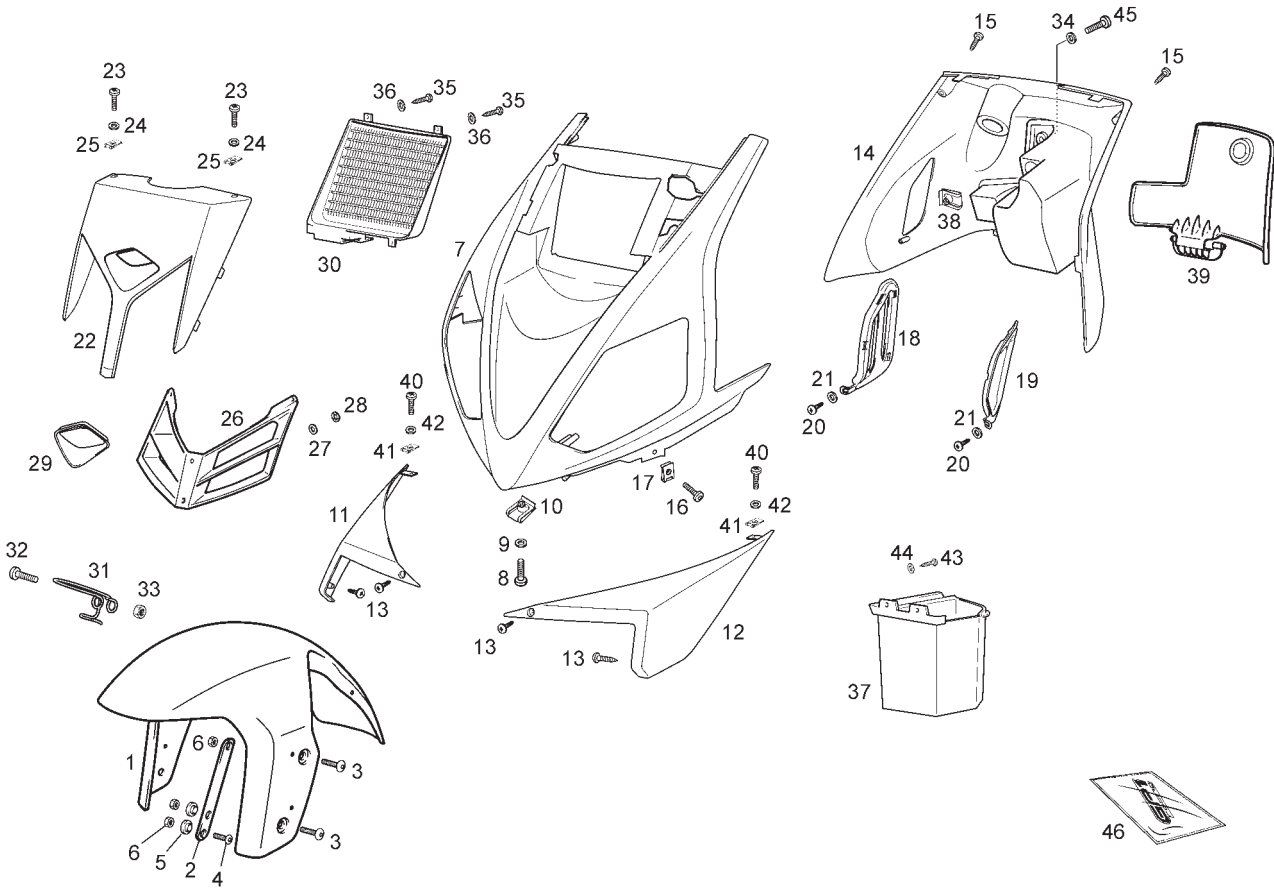

Fig.	Ver.	COD. KOD.	DESCRIPCIÓN DENOMINAZIONE NAME	BEZEICHUNG DESIGNATION	MOD.	NOTAS NOTES NOTA MITSCHRIFT NOTES
01A		00G00715022	GUARDABARRO DELANTERO PARAFANGO ANTERIORE FRONT MUDGUARD	VORDERES SCHMUTZBLECH GARDE-BOUE AVANT	1	
01B		00G00715023	GUARDABARRO DELANTERO PARAFANGO ANTERIORE FRONT MUDGUARD	VORDERES SCHMUTZBLECH GARDE-BOUE AVANT	2	
02A		00G00701051	SOPORTE GUARDABARRO DELANTERO SUPPORTO BRACKET	HALTERUNG SUPPORT	1 2	
03A		00H01503701	TORNILLO FIJACION INOX 6X25 VITE SCREW	SCHRAUBE VIS	1 2	
04A		00008062000	TORNILLO C/REDONDA ALLEN 6M100X20 VITE SCREW	SCHRAUBE VIS	1 2	
05A		00H00700321	CASQUILLO SEP. FIJ.GUARDABARRO DT GHIERA BUSH	DISTANZHULSE ENTRETOISE	1 2	
06A		00000023060	TUERCA AUTOBLOCANTE 6M100 DADO NUT	MUTTER ECROU	1 2	
07A		00G01505352	ESCUDO FRONTAL SCUDO ANTERIORE FRONT SHIELD	FRONTSCHILD ECU FRONTAL	1	
07B		00G01505353	ESCUDO FRONTAL SCUDO ANTERIORE FRONT SHIELD	FRONTSCHILD ECU FRONTAL	2	
08A		00012162000	TORNILLO C/REDONDA CRUZ 6M100X20 VITE SCREW	SCHRAUBE VIS	1 2	
09A		00031106000	ARANDELA PLANA D6 RONDELLA WASHER	SCHEIBE RONDELLE	1 2	



**PIEZAS SIN CALCAS  
PARTS WITHOUT DECALS**

Fig.	Ver.	COD. KOD.	DESCRIPCIÓN DENOMINAZIONE NAME	BEZEICHNUNG DESIGNATION	MOD.	NOTAS NOTES NOTA MITSCHRIFT NOTES
10A		00D01501371	TUERCA FIJACION D6 DADO NUT	MUTTER ECROU	1 2	
11A		00G01800021	TOMA AIRE FRONTAL DERECHA ENTRARE ARIA FRONTALE DX FRONT RH AIR INTAKE	LUFTDECKEL FRONTAL DR. AIR ENGAGER	1 2	
12A		00G01800031	TOMA AIRE FRONTAL IZQUIERDA ENTRARE ARIA FRONTALE SX FRONT LH AIR INTAKE	LUFTDECKEL FRONTAL GA. AIR ENGAGER	1 2	
13A		00113031060	TORNILLO AUTOROSCANTE 3X10 VITE SCREW	SCHRAUBE VIS	1 2	
14A		00G04907761	INTERIOR ESCUDO FRONTAL CONTROSCUDO FRONT SHIELD INNER	FRONTSCHILD INNEN INTER.ECU FR.	1 2	
15A		00011031401	TORNILLO AUTOROSCANTE 3,6X14 VITE SCREW	SCHRAUBE VIS	1 2	
16A		00008051200	TORNILLO C/REDONDA ALLEN 5M80X12 VITE SCREW	SCHRAUBE VIS	1 2	
17A		00G04401462	TUERCA FIJACION D5 DADO NUT	MUTTER ECROU	1 2	
18A		00G03802301	REJILLA POSTERIOR DERECHA INFERRIATA GRID	GITTER GRILLE	1 2	
19A		00G03800401	REJILLA POSTERIOR IZQUIERDA INFERRIATA GRID	GITTER GRILLE	1 2	
20A		00011031001	TORNILLO AUTOROSCANTE 3,6X10 VITE SCREW	SCHRAUBE VIS	1 2	

**PIEZAS SIN CALCAS  
PARTS WITHOUT DECALS**

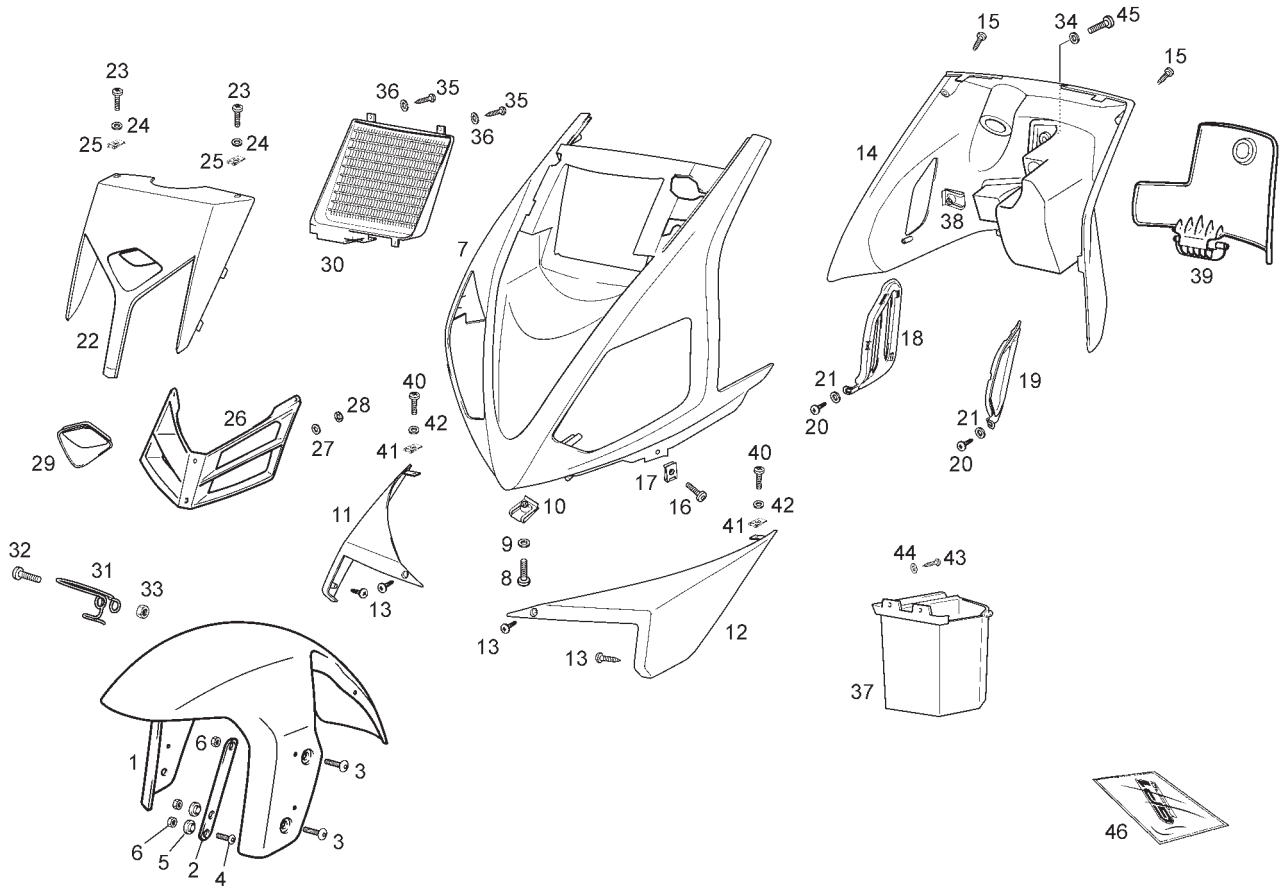
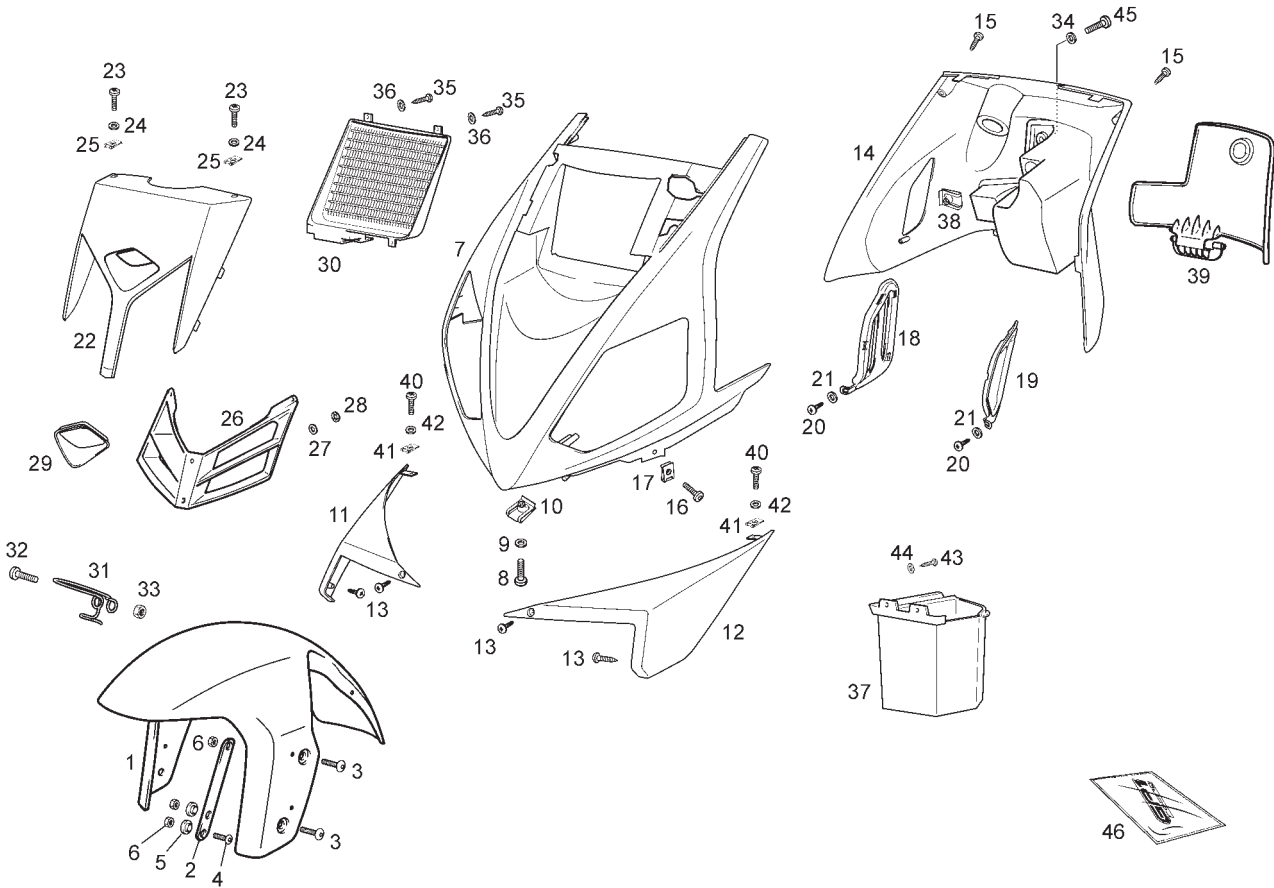

Fig.	Ver.	COD. KOD.	DESCRIPCIÓN DENOMINAZIONE NAME	BEZEICHUNG DESIGNATION	MOD.	NOTAS NOTES NOTA MITSCHRIFT NOTES
21A		00000031040	ARANDELA PLANA D4,3 RONDELLA WASHER	SCHEIBE RONDELLE	1 2	
22A		00G05905911	TAPA ESCUDO FRONTAL COPERCHIO COVER	DECKEL COUVERCLE	1 2	
23A		00012151500	TORNILLO C/REDONDA CRUZ 5M80X16 VITE SCREW	SCHRAUBE VIS	1 2	
24A		00000031050	ARANDELA PLANA D5 RONDELLA WASHER	SCHEIBE RONDELLE	1 2	
25A		00G04401462	TUERCA FIJACION D5 DADO NUT	MUTTER ECROU	1 2	
26A		00G03803301	REJILLA ESCUDO FRONTAL INFERRIATA GRID	GITTER GRILLE	1 2	
27A		00H01500741	ARANDELA RONDELLA WASHER	SCHEIBE RONDELLE	1 2	
28A		00G06300671	ARANDELA FIJACION RONDELLA WASHER	SCHEIBE RONDELLE	1 2	
29A		00G05703141	PROTECTOR OPTICA POSICION PROTEZIONE PROTECTOR	ABDECKUNG PROTECTEUR	1 2	
30A		00G03804301	REJILLA INTERIOR ESCUDO FRONTAL INFERRIATA GRID	GITTER GRILLE	1 2	
31A		639426	BRIDA FIJACION CABLE CTAKMS FLANGIA CLAMP	BINDER COLLIER	1 2	



**PIEZAS SIN CALCAS  
PARTS WITHOUT DECALS**

Fig.	Ver.	COD. KOD.	DESCRIPCIÓN DENOMINAZIONE NAME	BEZEICHNUNG DESIGNATION	MOD.	NOTAS NOTES NOTA MITSCHRIFT NOTES
32A		00G03000211	TORNILLO FIJACION 6X25 VITE SCREW	SCHRAUBE VIS	1 2	
33A		00000023060	TUERCA AUTOBLOCANTE 6M100 DADO NUT	MUTTER ECROU	1 2	
34A		00031106000	ARANDELA PLANA D6 RONDELLA WASHER	SCHEIBE RONDELLE	1 2	
35A		00011031001	TORNILLO AUTOROSCANTE VITE SCREW	SCHRAUBE VIS	1 2	
36A		00000031050	ARANDELA PLANA D5 RONDELLA WASHER	SCHEIBE RONDELLE	1 2	
37A		00G01503681	CAJA MALETA ESCUDO FRONTAL SCATOLA BOX	KASTEN BOITE	1 2	
38A		00D01501371	TUERCA FIJACION D6 DADO NUT	MUTTER ECROU	1 2	
39A		00G05911911	TAPA MALETA ESCUDO FRONTAL COPERCHIO COVER	DECKEL COUVERCLE	1 2	
40A		00012151500	TORNILLO C/REDONDA CRUZ 5M80X16 VITE SCREW	SCHRAUBE VIS	1 2	
41A		00G04401462	TUERCA FIJACION D5 DADO NUT	MUTTER ECROU	1 2	
42A		00000031050	ARANDELA PLANA D5 RONDELLA WASHER	SCHEIBE RONDELLE	1 2	

**PIEZAS SIN CALCAS  
PARTS WITHOUT DECALS**

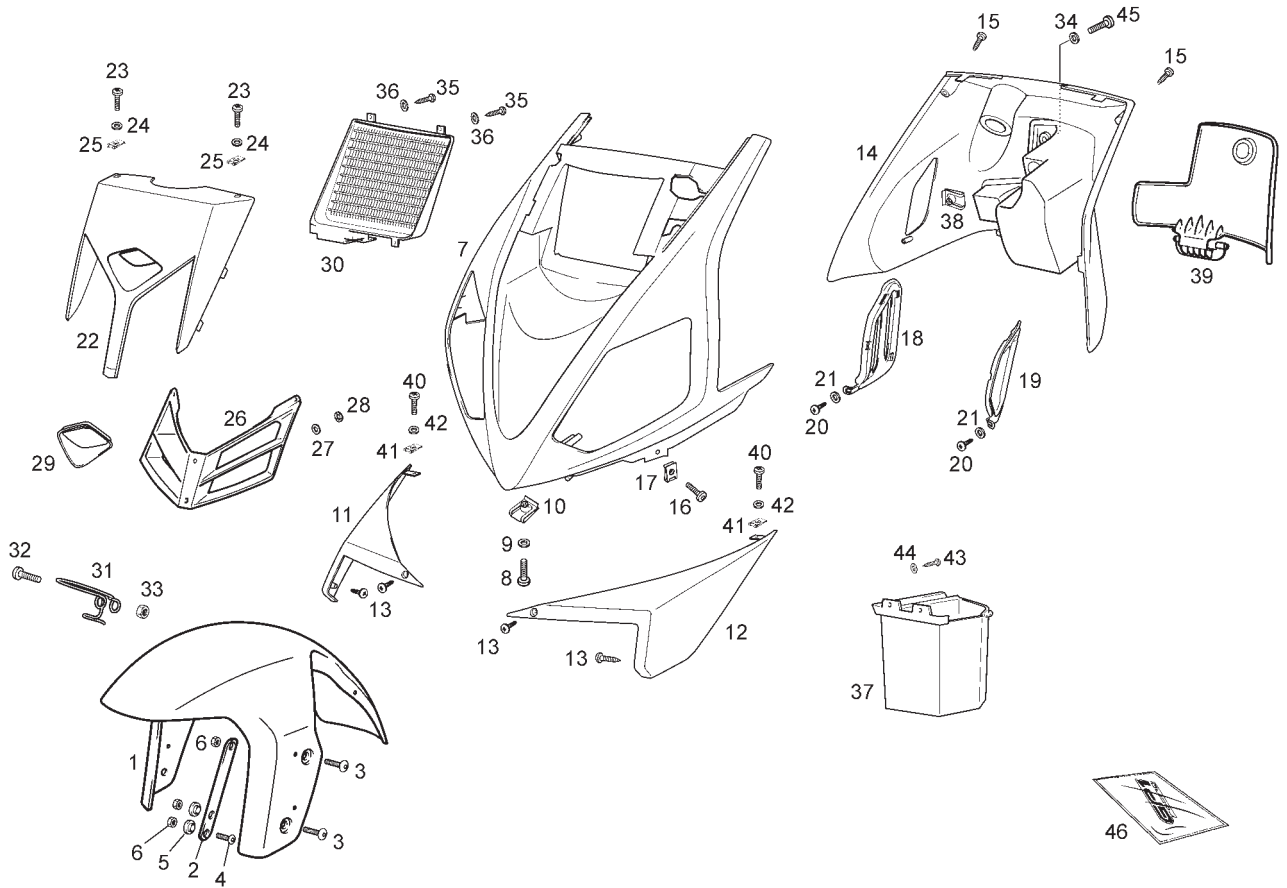
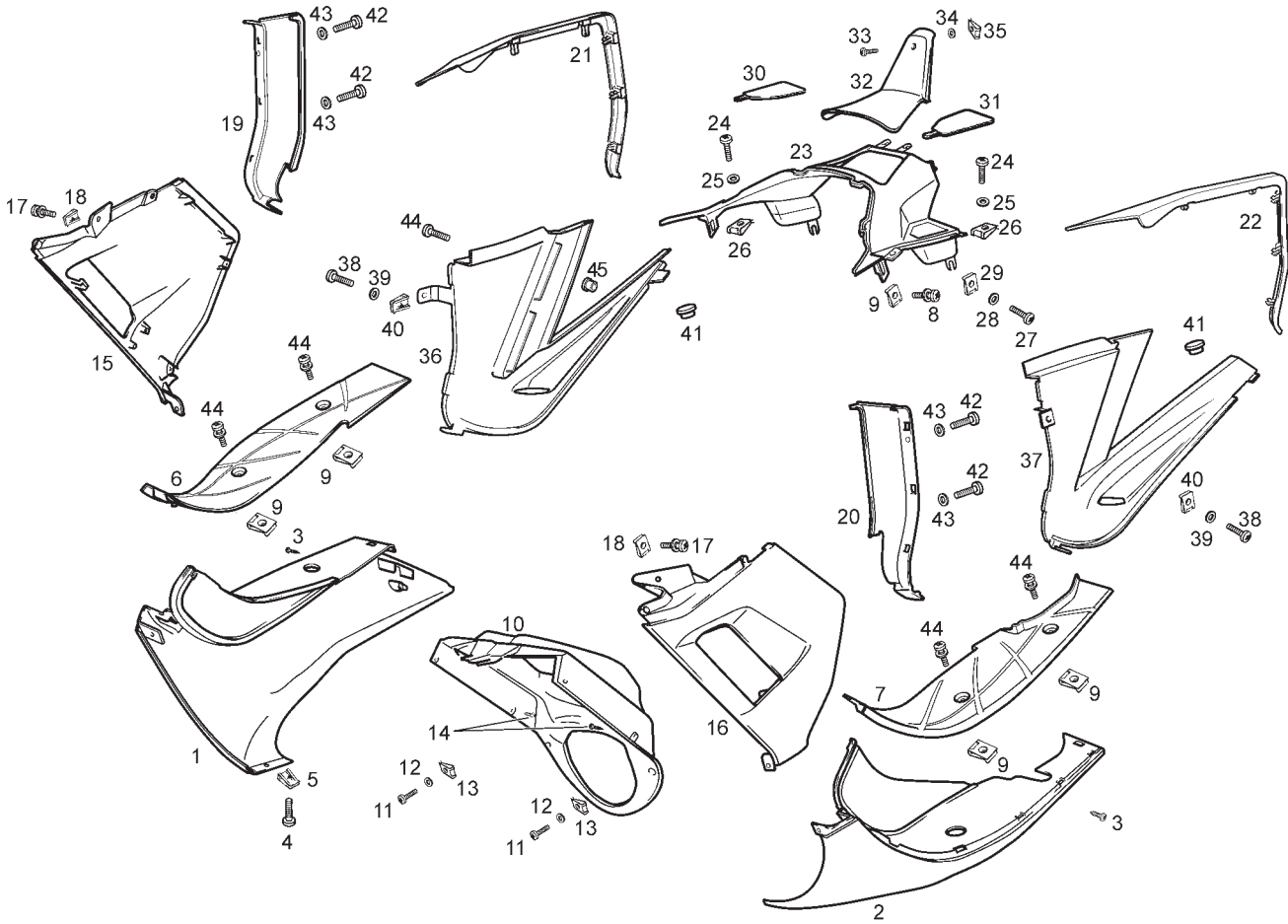

Fig.	Ver.	COD. KOD.	DESCRIPCIÓN DENOMINAZIONE NAME	BEZEICHNUNG DESIGNATION	MOD.	NOTAS NOTES NOTA MITSCHRIFT NOTES
43A		00011942000	TORNILLO AUTOROSCANTE 4,5X20 VITE SCREW	SCHRAUBE VIS	1 2	
44A		00000031050	ARANDELA PLANA D5 RONDELLA WASHER	SCHEIBE RONDELLE	1 2	
45A		00008061500	TORNILLO C/REDONDA ALLEN 6M100X16 VITE SCREW	SCHRAUBE VIS	1 2	
46A		86444800WN0	JUEGO CALCAS GP1 LS250 NEGRO COMPL.ADESIVI DECALS ASSY	AUFKLEBERSATZ JEU ADHESIF	1	
46B		86444800WG0	JUEGO CALCAS GP1 LS250 GRIS COMPL.ADESIVI DECALS ASSY	AUFKLEBERSATZ JEU ADHESIF	2	



**PIEZAS SIN CALCAS  
PARTS WITHOUT DECALS**

Fig.	Ver.	COD. KOD.	DESCRIPCIÓN DENOMINAZIONE NAME	BEZEICHNUNG DESIGNATION	MOD.	NOTAS NOTES NOTA MITSCHRIFT NOTES
01A		86441200W4G	QUILLA INFERIOR DERECHA COPERCHIO INF. DX. LOWER RH SIDE COVER	SEITENABDECKUNG UNTERE RECHT COUVERCLE INF. DR.	1 2	
02A		86441300W4G	QUILLA INFERIOR IZQUIERDA COPERCHIO INF. SX. LOWER LH SIDE COVER	SEITENABDECKUNG UNTERE LINKS COUVERCLE INF. GA.	1 2	
03A		00011142500	TORNILLO AUTORROS. C/CRUZ 4,2X25 VITE SCREW	SCHRAUBE VIS	1 2	
04A		00H06300861	TORNILLO FIJACION 6X14 VITE SCREW	SCHRAUBE VIS	1 2	
05A		00D01501371	TUERCA FIJACION D6 DADO NUT	MUTTER ECROU	1 2	
06A		00G01507091	REPOSAPIES DERECHO APPOGGIAPIEDI FOOTREST	FUSS-STUETZE REPOSE-PIED	1 2	
07A		00G01502451	REPOSAPIES IZQUIERDO APPOGGIAPIEDI FOOTREST	FUSS-STUETZE REPOSE-PIED	1 2	
08A		00F05900041	SCTO.TORNILLO 6M100X16 VITE SCREW	SCHRAUBE VIS	1 2	
09A		00D01501371	TUERCA FIJACION D6 DADO NUT	MUTTER ECROU	1 2	
10A		863409	GUARDABARRO DELANTERO INTERIOR PARAFANGO INTERIORE INNER MUDGUARD	SCHMUTZBLECH GARDE-BOUE	1 2	
11A		00012162000	TORNILLO C/REDONDA CRUZ 6M100X20 VITE SCREW	SCHRAUBE VIS	1 2	

**PIEZAS SIN CALCAS  
PARTS WITHOUT DECALS**

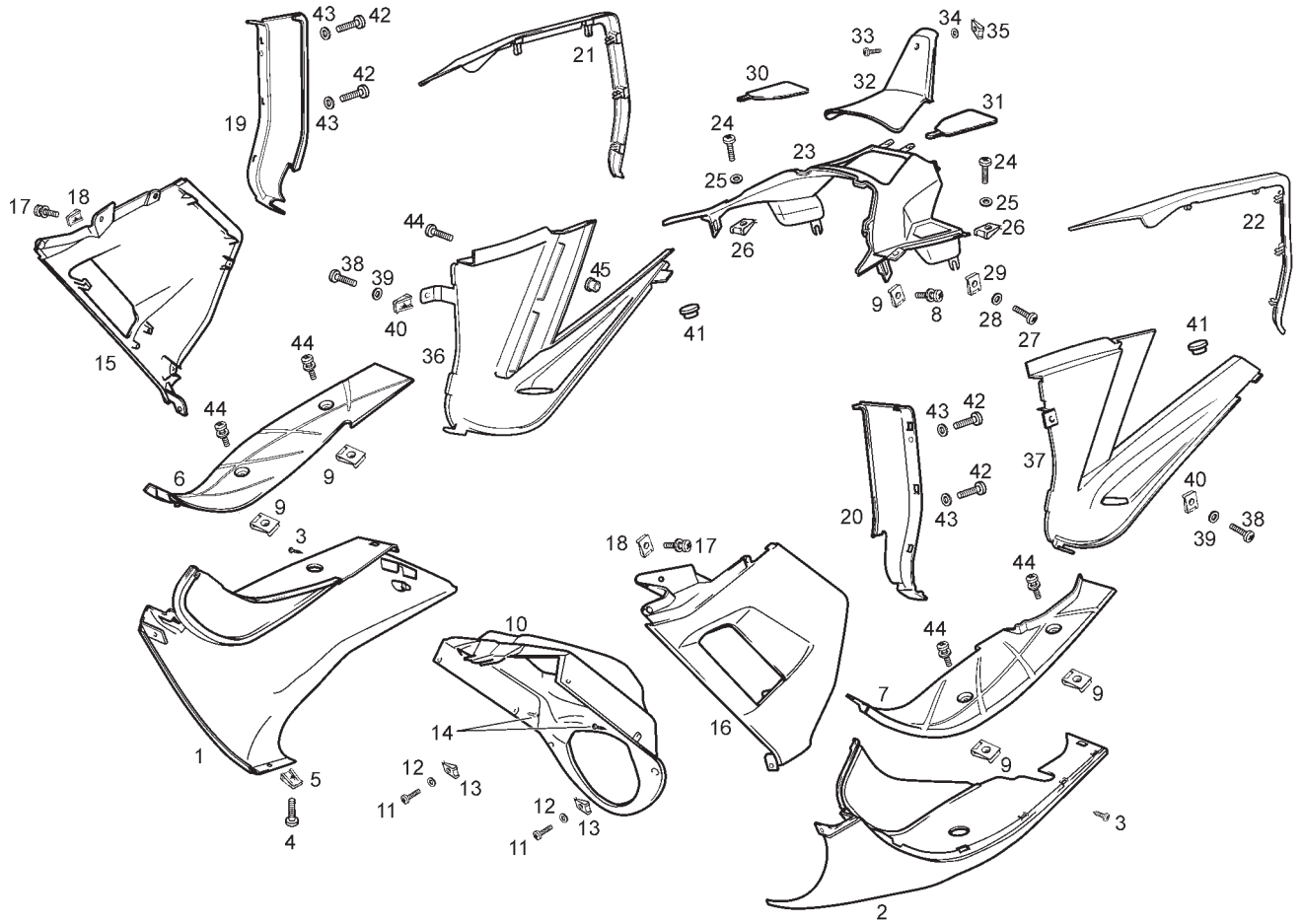
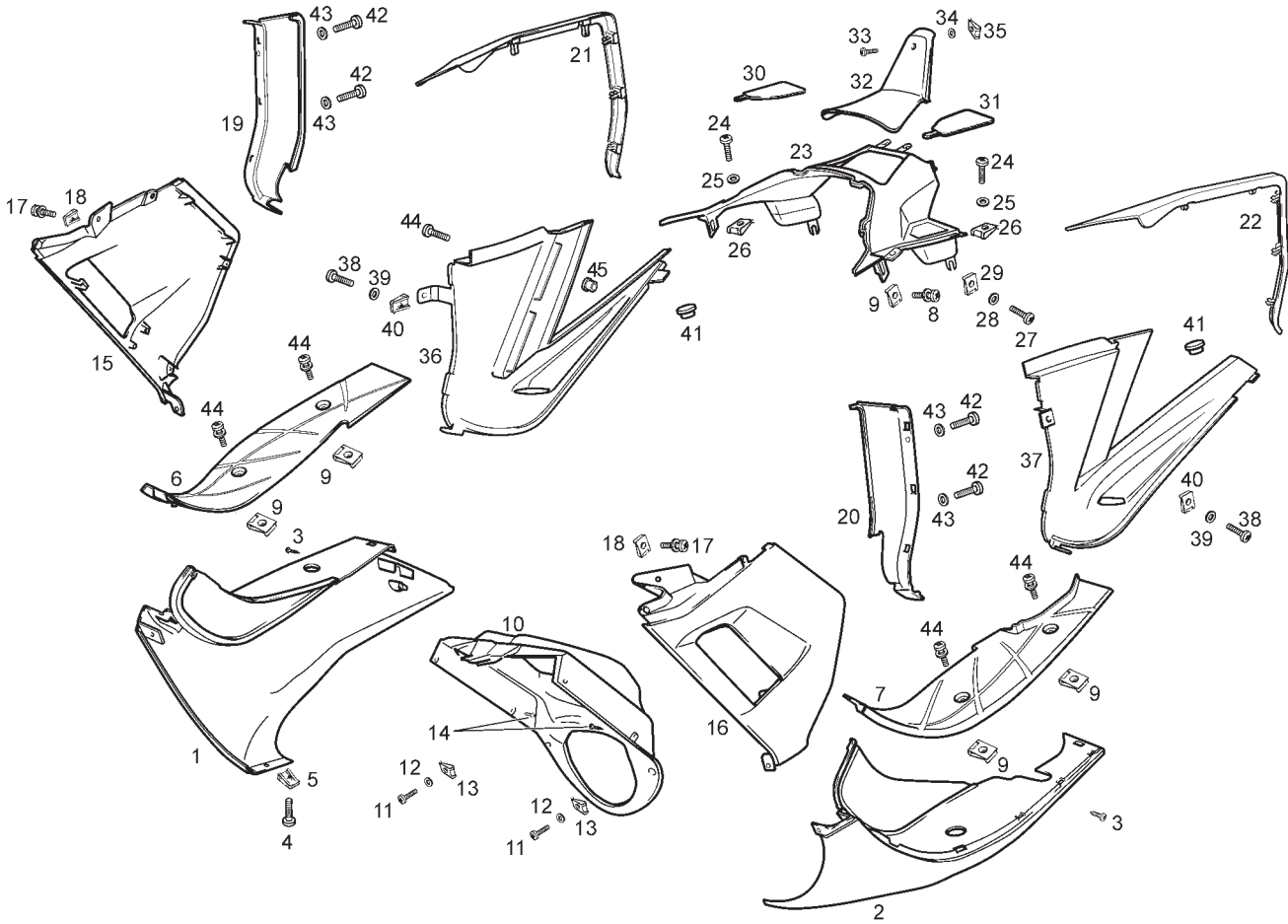

Fig.	Ver.	COD. KOD.	DESCRIPCIÓN DENOMINAZIONE NAME	BEZEICHNUNG DESIGNATION	MOD.	NOTAS NOTES NOTA MITSCHRIFT NOTES
12A		00031106000	ARANDELA PLANA D6 RONDELLA WASHER	SCHEIBE RONDELLE	1 2	
13A		00D01501371	TUERCA FIJACION D6 DADO NUT	MUTTER ECROU	1 2	
14A		00011031001	TORNILLO AUTOROSCANTE 3,6X10 VITE SCREW	SCHRAUBE VIS	1 2	
15A		00G01508232	TAPA LATERAL DERECHA COPERCHIO COVER	DECKEL COUVERCLE	1	
15B		00G01508233	TAPA LATERAL DERECHA COPERCHIO COVER	DECKEL COUVERCLE	2	
16A		00G06816322	TAPA LATERAL IZQUIERDA COPERCHIO COVER	DECKEL COUVERCLE	1	
16B		00G06816323	TAPA LATERAL IZQUIERDA COPERCHIO COVER	DECKEL COUVERCLE	2	
17A		00F05900041	SCTO.TORNILLO 6M100X16 VITE SCREW	SCHRAUBE VIS	1 2	
18A		00D01501371	TUERCA FIJACION D6 DADO NUT	MUTTER ECROU	1 2	
19A		00G04403771	TAPA INFERIOR CUBREDEPOSITO DR. COPERCHIO COVER	DECKEL COUVERCLE	1 2	
20A		00G04403781	TAPA INFERIOR CUBREDEPOSITO IZ. COPERCHIO COVER	DECKEL COUVERCLE	1 2	



**PIEZAS SIN CALCAS  
PARTS WITHOUT DECALS**

Fig.	Ver.	COD. KOD.	DESCRIPCIÓN DENOMINAZIONE NAME	BEZEICHNUNG DESIGNATION	MOD.	NOTAS NOTES NOTA MITSCHRIFT NOTES
21A		00G04400971	CUBRE LATERAL DRCHO GP1 COPERCHIO COVER	DECKEL COUVERCLE	1 2	
22A		00G04400981	CUBRE LATERAL IZDO. GP1 COPERCHIO COVER	DECKEL COUVERCLE	1 2	
23A		00G00401681	CUBREDEPOSITO GASOLINA COPERCHIO COVER	DECKEL COUVERCLE	1 2	
24A		00012151500	TORNILLO C/REDONDA CRUZ 5M80X16 VITE SCREW	SCHRAUBE VIS	1 2	
25A		00000031050	ARANDELA PLANA D5 RONDELLA WASHER	SCHEIBE RONDELLE	1 2	
26A		00G04401462	TUERCA FIJACION D5 DADO NUT	MUTTER ECROU	1 2	
27A		00012151500	TORNILLO C/REDONDA CRUZ 5M80X16 VITE SCREW	SCHRAUBE VIS	1 2	
28A		00000031050	ARANDELA PLANA D5 RONDELLA WASHER	SCHEIBE RONDELLE	1 2	
29A		00G04401462	TUERCA FIJACION D5 DADO NUT	MUTTER ECROU	1 2	
30A		00G05907911	TAPA DERECHA CUBREDEPOSITO COPERCHIO COVER	DECKEL COUVERCLE	1 2	
31A		00G05908911	TAPA IZQUIERDA CUBREDEPOSITO COPERCHIO COVER	DECKEL COUVERCLE	1 2	

**PIEZAS SIN CALCAS  
PARTS WITHOUT DECALS**

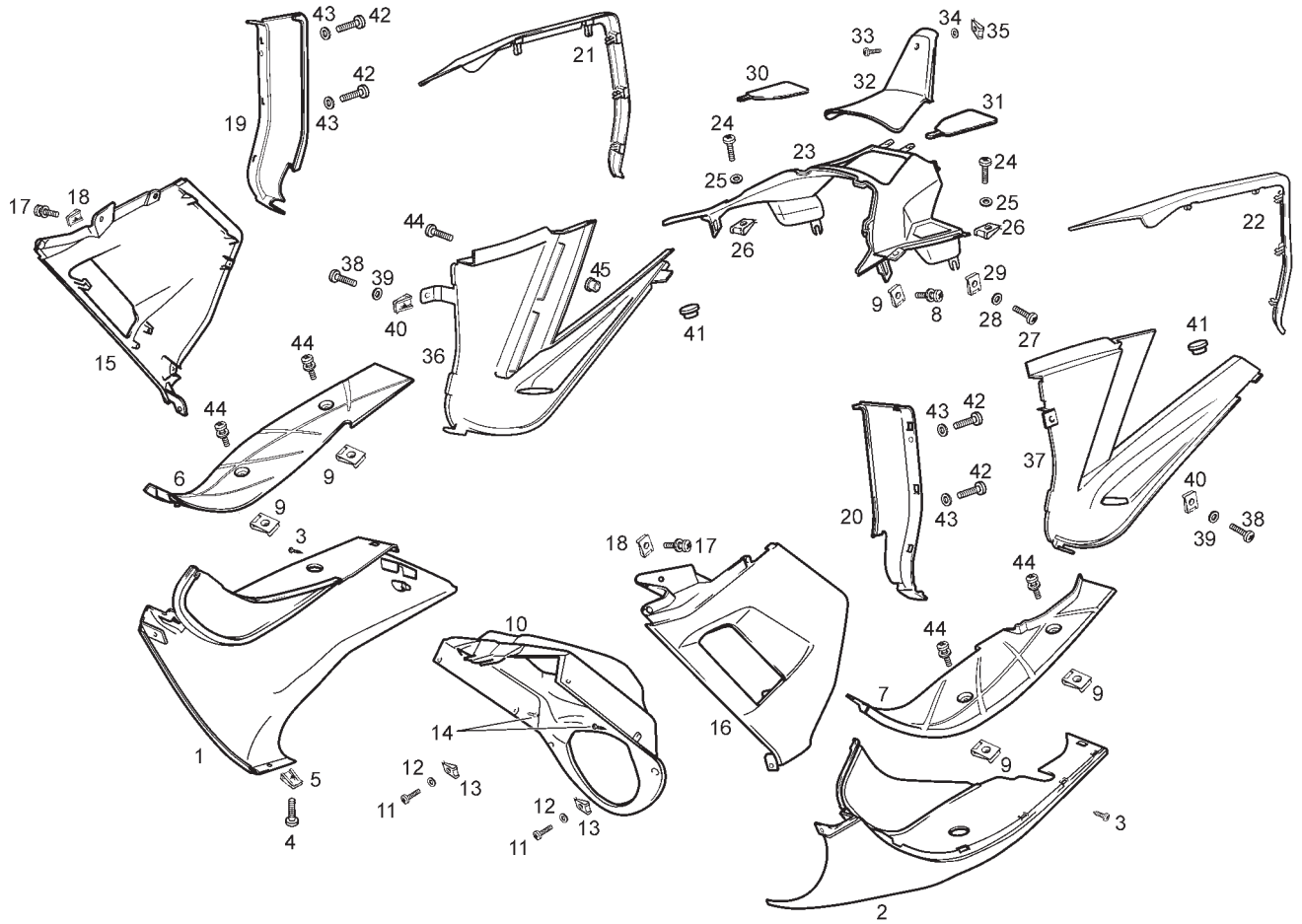
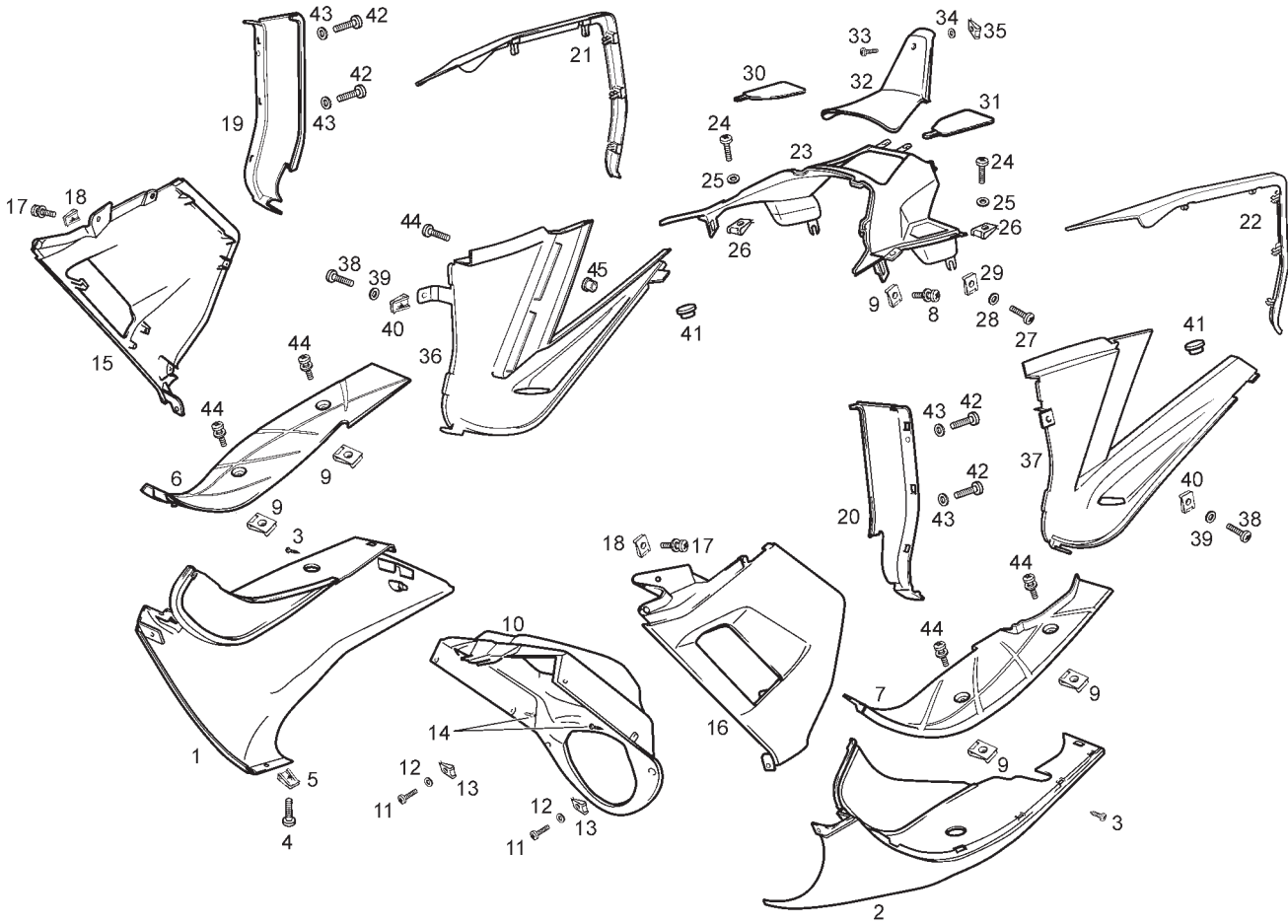

Fig.	Ver.	COD. KOD.	DESCRIPCIÓN DENOMINAZIONE NAME	BEZEICHNUNG DESIGNATION	MOD.	NOTAS NOTES NOTA MITSCHRIFT NOTES
32A		00G05906911	TAPA CENTRAL CUBREDEPOSITO COPERCHIO COVER	DECKEL COUVERCLE	1 2	
33A		00008051200	TORNILLO C/REDONDA ALLEN 5M80X12 VITE SCREW	SCHRAUBE VIS	1 2	
34A		00000031050	ARANDELA PLANA D5 RONDELLA WASHER	SCHEIBE RONDELLE	1 2	
35A		00G04401462	TUERCA FIJACION D5 DADO NUT	MUTTER ECROU	1 2	
36A		862596	TAPA LATERAL DR. CUBREDEPOSITO COPERCHIO COVER	DECKEL COUVERCLE	1 2	
37A		862597	TAPA LATERAL IZ. CUBREDEPOSITO COPERCHIO COVER	DECKEL COUVERCLE	1 2	
38A		00012151500	TORNILLO C/REDONDA CRUZ 5M80X16 VITE SCREW	SCHRAUBE VIS	1 2	
39A		00000031050	ARANDELA PLANA D5 RONDELLA WASHER	SCHEIBE RONDELLE	1 2	
40A		00G04401462	TUERCA FIJACION D5 DADO NUT	MUTTER ECROU	1 2	
41A		864389	TAPON D7 NEGRO TAPPO CAP	KAPPE BOUCHON	1 2	
42A		00008051600	TORNILLO C/ESF ALLEN 5M80X16 VITE SCREW	SCHRAUBE VIS	1 2	



**PIEZAS SIN CALCAS  
PARTS WITHOUT DECALS**

Fig.	Ver.	COD. KOD.	DESCRIPCIÓN DENOMINAZIONE NAME	BEZEICHNUNG DESIGNATION	MOD.	NOTAS NOTES NOTA MITSCHRIFT NOTES
43A		00000031050	ARANDELA PLANA D5 RONDELLA WASHER	SCHEIBE RONDELLE	1 2	
44A		00H05900021	SCTO. TORNILLO 6M100X16 VITE SCREW	SCHRAUBE VIS	1 2	
45A		00H04401711	TUERCA NYLON DADO NUT	MUTTER ECROU	1 2	

**PIEZAS SIN CALCAS  
PARTS WITHOUT DECALS**

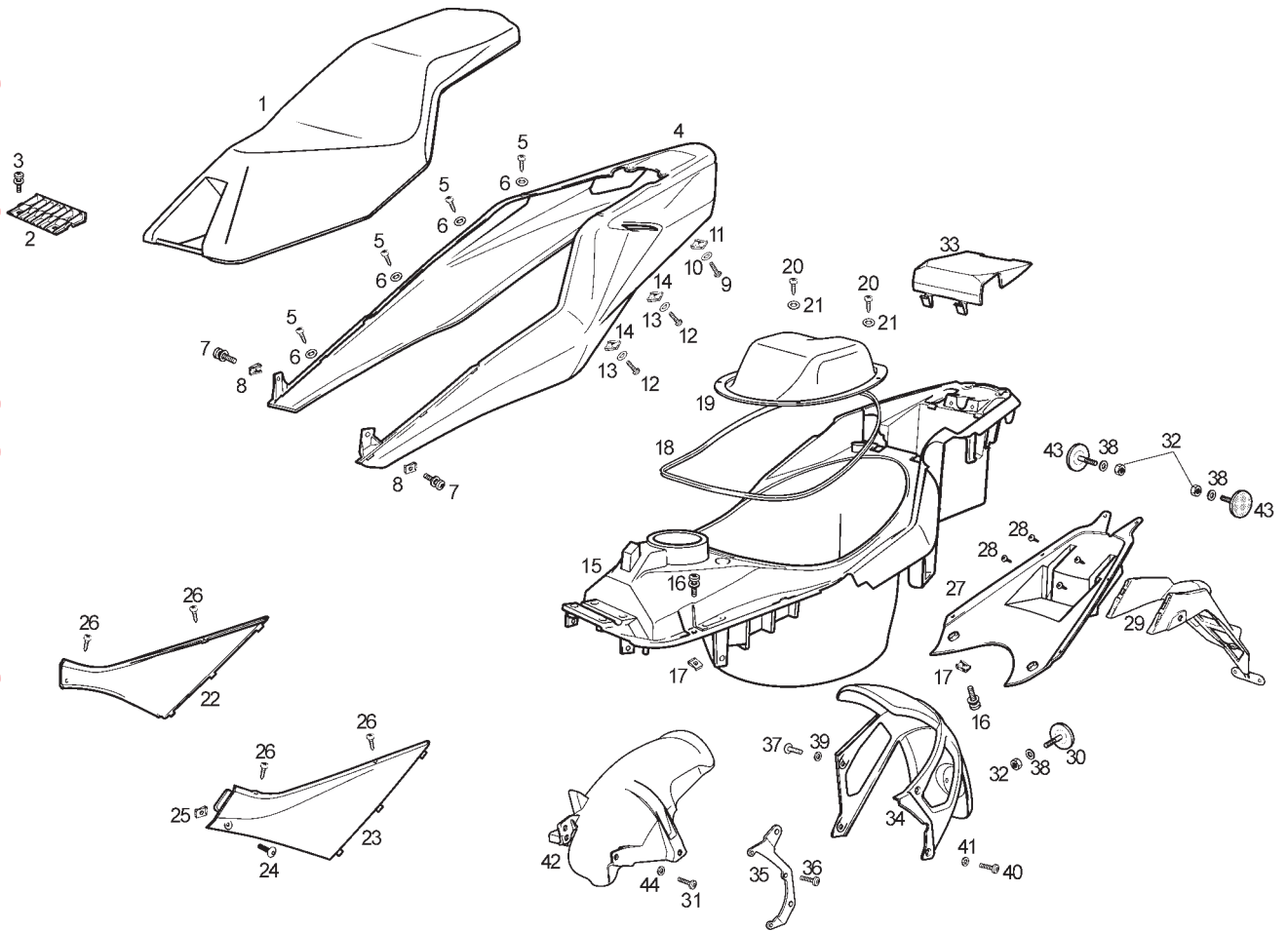
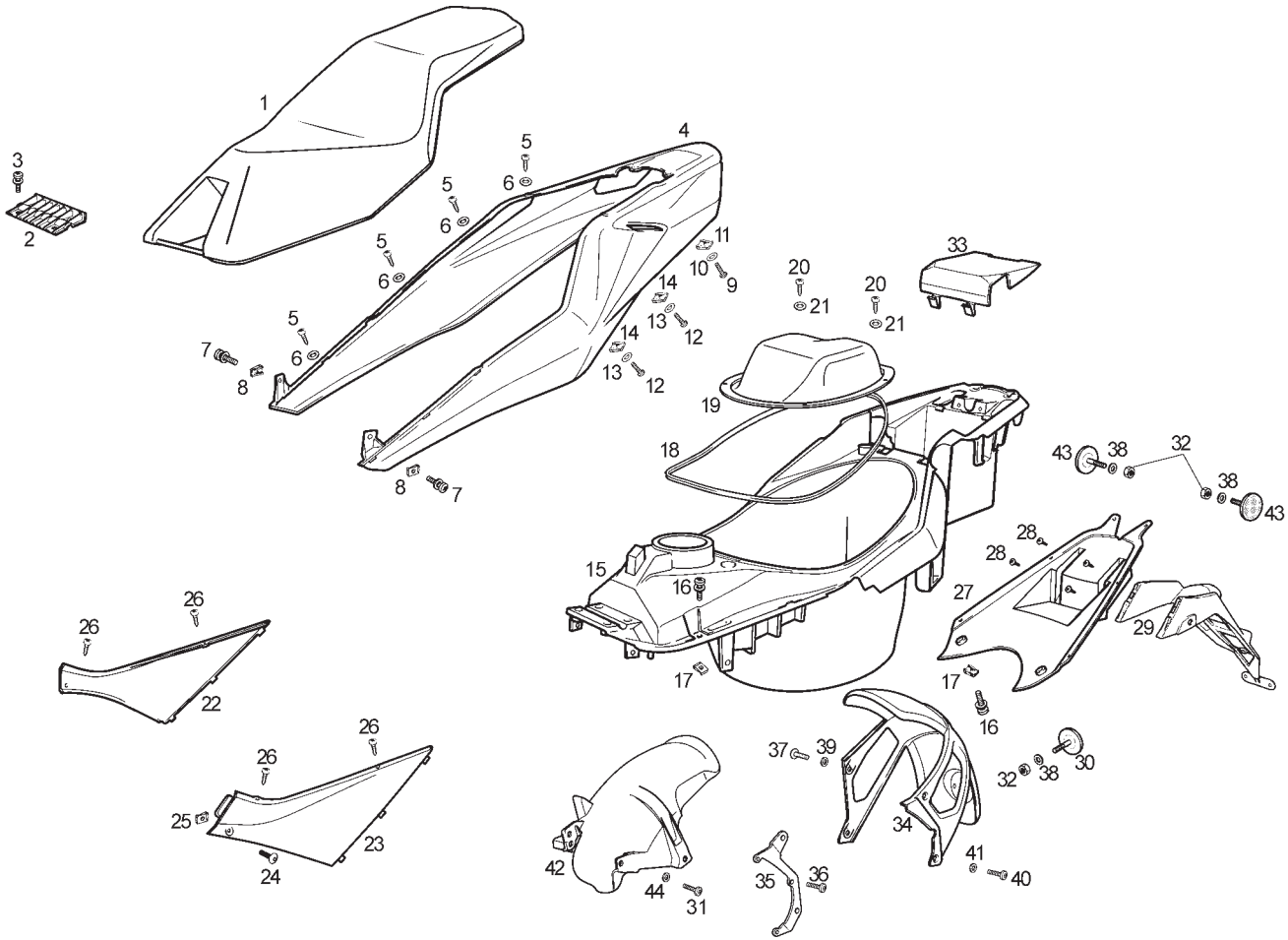

Fig.	Ver.	COD. KOD.	DESCRIPCIÓN DENOMINAZIONE NAME	BEZEICHNUNG DESIGNATION	MOD.	NOTAS NOTES NOTA MITSCHRIFT NOTES
01A		8631830001	CTO SILLIN SELLA SEAT	SITZ ENSEMBLE SELLE	1 2	
02A		00G05905941	ARTICULACION SILLIN ASSE AXLE	ACHSE AXE	1 2	
03A		00F05900091	SCTO.TORNILLO 6M100X20 VITE SCREW	SCHRAUBE VIS	1 2	
04A		00G00607162	COLIN COLIN SELLINO SEAT BASE	KOTFLUGEL HINTEN DOSSERET SELLE	1	
04B		00G00607163	COLIN COLIN SELLINO SEAT BASE	KOTFLUGEL HINTEN DOSSERET SELLE	2	
05A		00011031401	TORNILLO AUTOROSCANTE 3,6X14 VITE SCREW	SCHRAUBE VIS	1 2	
06A		00H04901411	ARANDELA FIJACION RONDELLA WASHER	SCHRAUBE VIS	1 2	
07A		00F05900041	SCTO.TORNILLO 6M100X16 VITE SCREW	SCHRAUBE VIS	1 2	
08A		00D01501371	TUERCA FIJACION D6 DADO NUT	MUTTER ECROU	1 2	
09A		00008051600	TORNILLO C/ESFERICA ALLEN 5M80X16 VITE SCREW	SCHRAUBE VIS	1 2	



**PIEZAS SIN CALCAS  
PARTS WITHOUT DECALS**

Fig.	Ver.	COD. KOD.	DESCRIPCIÓN DENOMINAZIONE NAME	BEZEICHNUNG DESIGNATION	MOD.	NOTAS NOTES NOTA MITSCHRIFT NOTES
10A		00D02600631	ARANDELA RONDELLA WASHER	SCHEIBE RONDELLE	1 2	
11A		00G04401462	TUERCA FIJACION D5 DADO NUT	MUTTER ECROU	1 2	
12A		00008051200	TORNILLO C/REDONDA ALLEN 5M80X12 VITE SCREW	SCHRAUBE VIS	1 2	
13A		00000031050	ARANDELA PLANA D5 RONDELLA WASHER	SCHEIBE RONDELLE	1 2	
14A		00G04401462	TUERCA FIJACION D5 DADO NUT	MUTTER ECROU	1 2	
15A		863599	PORTACASCOS PORTA-ELMO TRUNK	HELMFACH PORTE-CASQUE	1 2	
16A		00F05900041	SCTO.TORNILLO 6M100X16 VITE SCREW	SCHRAUBE VIS	1 2	
17A		00D01501371	TUERCA FIJACION D6 DADO NUT	MUTTER ECROU	1 2	
18A		00G06301551	JUNTA PERFIL PORTACASCO VANO CASCO HELMET BOX RUBBER SEAL PROT.	DICHTGUMMI HELMTRAEGER PROFIL PORTE-CASQUE	1 2	
19A		863601	TAPA ACCESO CARBURADOR COPERCHIO COVER	DECKEL COUVERCLE	1 2	

**PIEZAS SIN CALCAS  
PARTS WITHOUT DECALS**

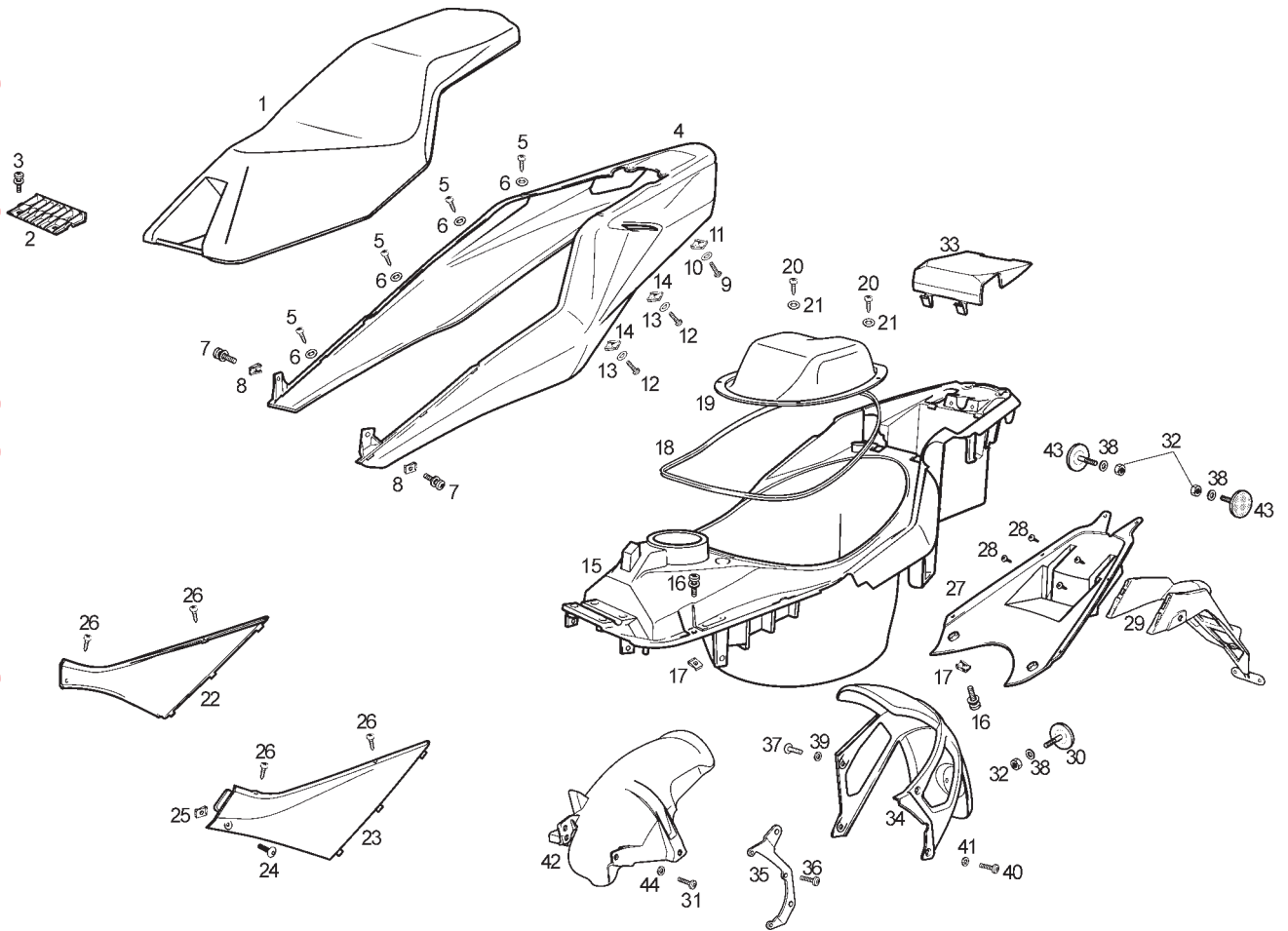
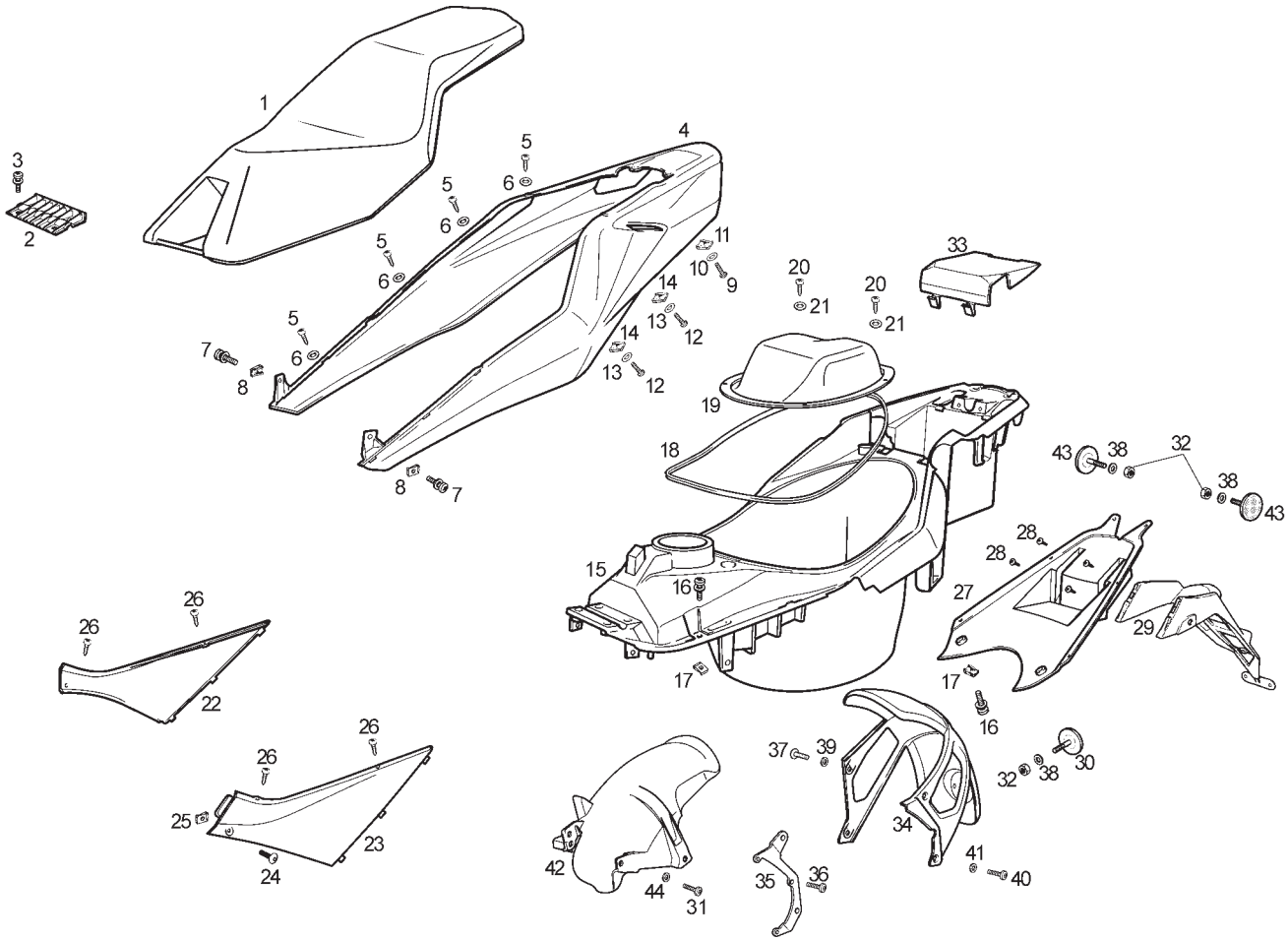

Fig.	Ver.	COD. KOD.	DESCRIPCIÓN DENOMINAZIONE NAME	BEZEICHNUNG DESIGNATION	MOD.	NOTAS NOTES MITSCHRIFT NOTES
20A		00011031401	TORNILLO AUTOROSCANTE 3,6X14 VITE SCREW	SCHRAUBE VIS	1 2	
21A		00000031050	ARANDELA PLANA D5 RONDELLA WASHER	SCHEIBE RONDELLE	1 2	
22A		00G06101181	ADORNO LATERAL SILLIN DERECHO COPERCHIO COVER	DECKEL COUVERCLE	1 2	
23A		00G06101191	ADORNO LATERAL SILLIN IZQUIERDO COPERCHIO COVER	DECKEL COUVERCLE	1 2	
24A		00008051600	TORNILLO C/ESFERICA ALLEN 5M80X16 VITE SCREW	SCHRAUBE VIS	1 2	
25A		00G04401462	TUERCA FIJACION D5 DADO NUT	MUTTER ECROU	1 2	
26A		00011031401	TORNILLO AUTOROSCANTE 3,6X14 VITE SCREW	SCHRAUBE VIS	1 2	
27A		863600	TAPA INFERIOR COLIN COPERCHIO COVER	DECKEL COUVERCLE	1 2	
28A		00011031401	TORNILLO AUTOROSCANTE 3,6X14 VITE SCREW	SCHRAUBE VIS	1 2	
29A		00H00717341	SUPLEMENTO GUARDABARRO TRASERO SUPPL. PARAFANGHI POSTERI REAR MUDGUARD EXTENSION	SPRITZSCHUTZ HINTEN SUPPL. GARDE-BOUE ARRIERE	1 2	



**PIEZAS SIN CALCAS  
PARTS WITHOUT DECALS**

Fig.	Ver.	COD. KOD.	DESCRIPCIÓN DENOMINAZIONE NAME	BEZEICHNUNG DESIGNATION	MOD.	NOTAS NOTES NOTA MITSCHRIFT NOTES
30A		00K05110651	CATADRIOPTICO ATV CATADIOTTRO REFLECTOR	RÜCKSTRAHLER CATADIOPTRE	1 2	
31A		00004163500	TORNILLO C/ALLEN 6M100X35 VITE SCREW	SCHRAUBE VIS	1 2	
32A		00000023040	TUERCA AUTOBLOCANTE 4M70 DADO NUT	MUTTER ECROU	1 2	
33A		00G01501901	TAPA BATERIA GP1 50CC 04 E2 COPERCHIO COVER	DECKEL COUVERCLE	1 2	
34A		949562000G	GUARDABARRO TRASERO POSTERIOR PARAFANGO POSTERIORE REAR MUDGUARD	KOTFLUGEL HI. GARDE-BOUE ARRIERE	1 2	
35A		949560	SOPORTE IZQUIERDO GUARDAB.TRAS. SUPPORTO BRACKET	STÜTZ SUPPORT	1 2	
36A		00G03001091	TORNILLO FIJACION 6X35 VITE SCREW	SCHRAUBE VIS	1 2	
37A		00008062000	TORNILLO C/REDONDA ALLEN 6M100X20 VITE SCREW	SCHRAUBE VIS	1 2	
38A		00D02600631	ARANDELA RONDELLA WASHER	SCHEIBE RONDELLE	1 2	
39A		00031106000	ARANDELA PLANA D6 RONDELLA WASHER	SCHEIBE RONDELLE	1 2	

**PIEZAS SIN CALCAS  
PARTS WITHOUT DECALS**

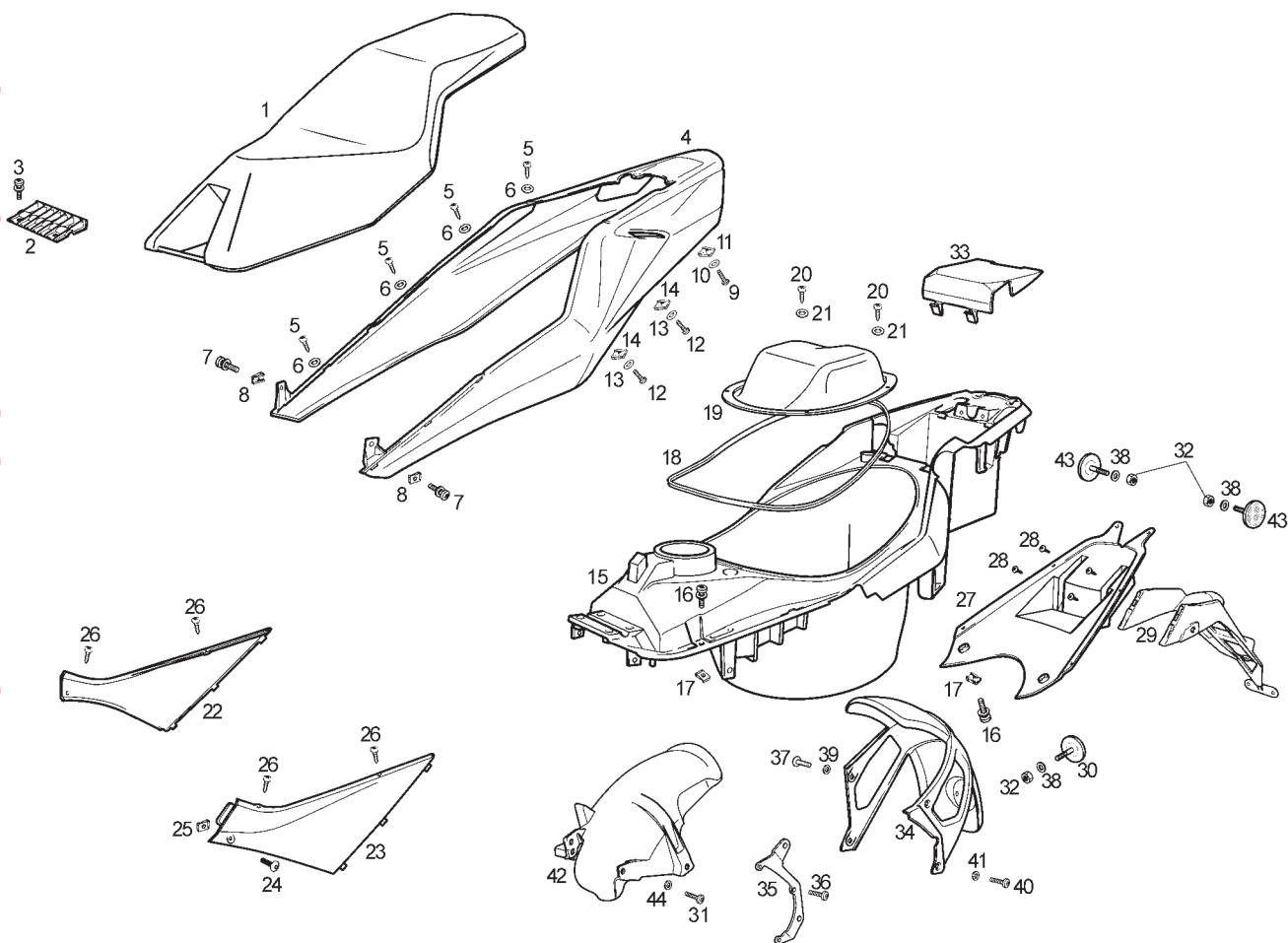

Fig.	Ver.	COD. KOD.	DESCRIPCIÓN DENOMINAZIONE NAME	BEZEICHNUNG DESIGNATION	MOD.	NOTAS NOTES NOTA MITSCHRIFT NOTES
40A		00008061500	TORNILLO C/REDONDA ALLEN 6M100X15 VITE SCREW	SCHRAUBE VIS	1 2	
41A		00031106000	ARANDELA PLANA D6 RONDELLA WASHER	SCHEIBE RONDELLE	1 2	
42A		863692	GUARDABARROS TRASERO PARAFANGO MUDGUARD	KOTFLUGEL GARDE-BOUE	1 2	
43A		00G04402751	CATADIOPTRICO CATADIOTTRO REFLECTOR	RÜCKSTRAHLER CATADIOPTRE	1 2	
44A		00402060001	ARANDELA D6 RONDELLA WASHER	SCHEIBE RONDELLE	1 2	

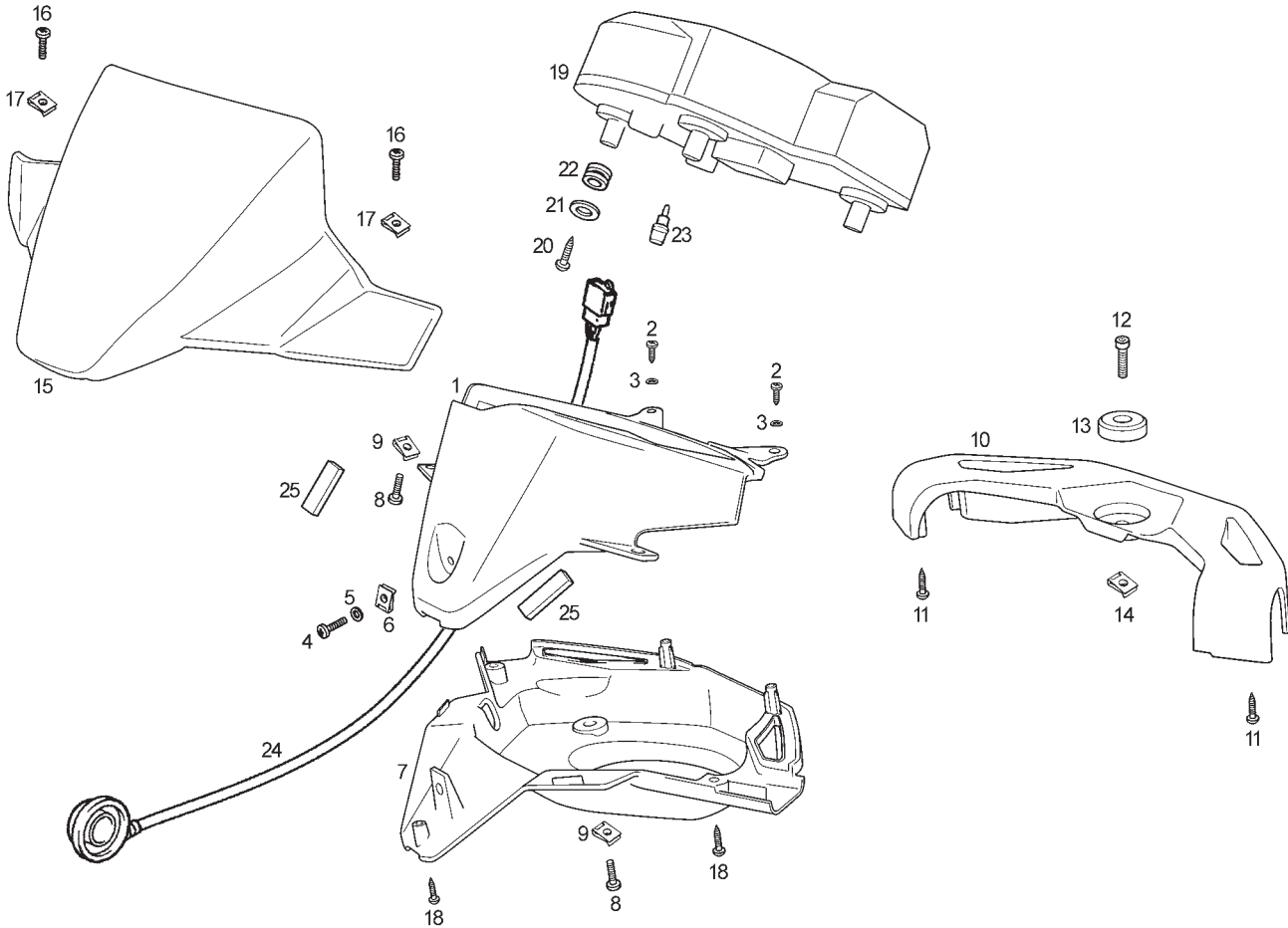

Fig.	Ver.	COD. KOD.	DESCRIPCIÓN DENOMINAZIONE NAME	BEZEICHNUNG DESIGNATION	MOD.	NOTAS NOTES NOTA MITSCHRIFT NOTES
01A		00G01016521	CARCASA SUPERIOR CARENATURA BODY PANEL	LENKERDEKEL CACHE DIRECTION	1 2	
02A		00011131401	TORNILLO AUTOROSCANTE 3X14 VITE SCREW	SCHRAUBE VIS	1 2	
03A		00000031050	ARANDELA PLANA D5 RONDELLA WASHER	SCHEIBE RONDELLE	1 2	
04A		00012162000	TORNILLO C/REDONDA CRUZ 6M100X20 VITE SCREW	SCHRAUBE VIS	1 2	
05A		00031106000	ARANDELA PLANA D6 RONDELLA WASHER	SCHEIBE RONDELLE	1 2	
06A		00D01501371	TUERCA FIJACION D6 DADO NUT	MUTTER ECROU	1 2	
07A		862564	CARCASA INFERIOR CARENATURA BODY PANEL	LENKERDEKEL CACHE DIRECTION	1 2	
08A		00012051200	TORNILLO C/REDONDA CRUZ 5M80X12 VITE SCREW	SCHRAUBE VIS	1 2	
09A		00G04401462	TUERCA FIJACION D5 DADO NUT	MUTTER ECROU	1 2	
10A		00G01501651	PLETINA CUBREMANILLAR COPERCHIO COVER	DECKEL COUVERCLE	1 2	
11A		00011131401	TORNILLO AUTOROSCANTE 3X14 VITE SCREW	SCHRAUBE VIS	1 2	

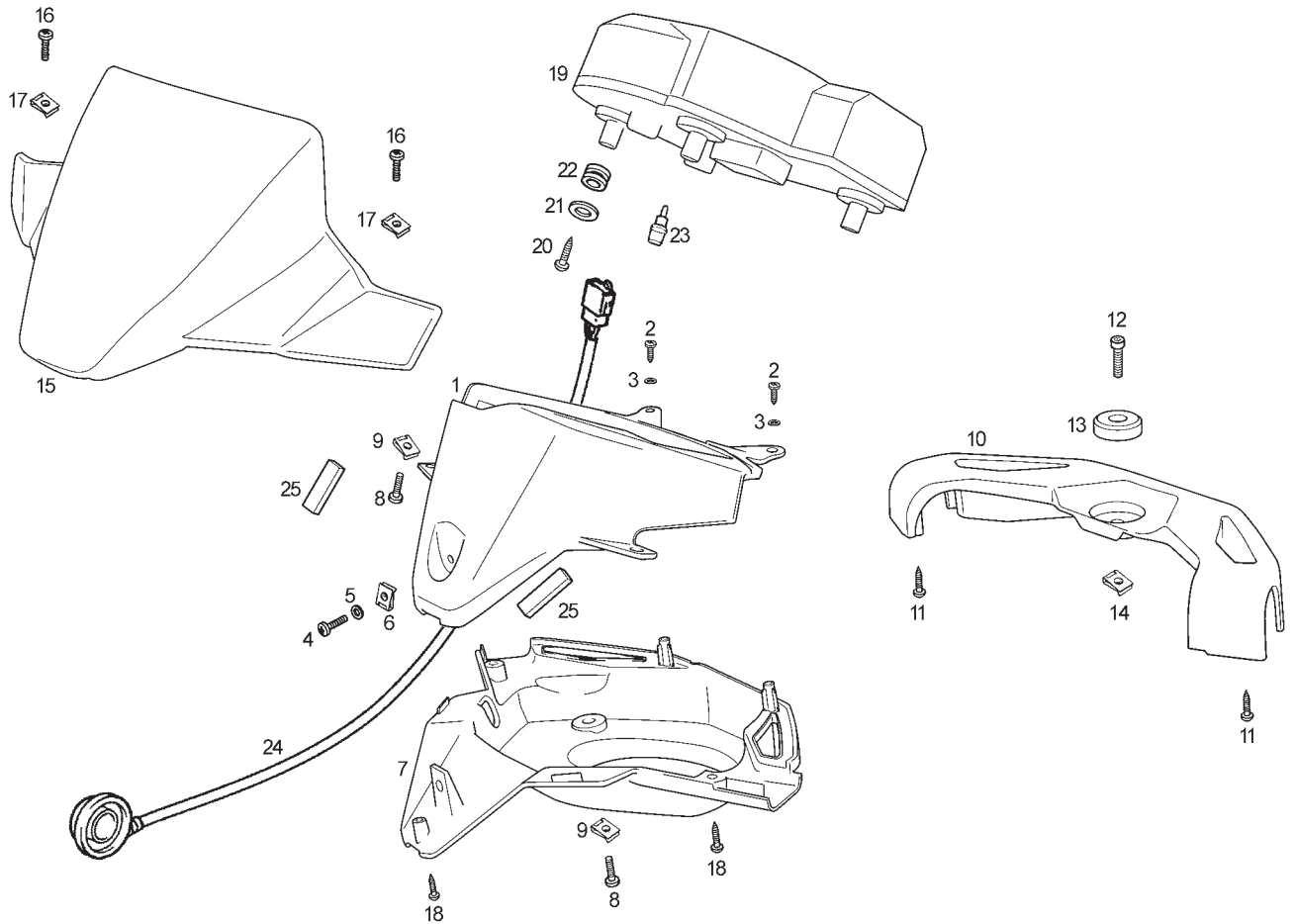

Fig.	Ver.	COD. KOD.	DESCRIPCIÓN DENOMINAZIONE NAME	BEZEICHNUNG DESIGNATION	MOD.	NOTAS NOTES NOTA MITSCHRIFT NOTES
12A		00002062011	TORNILLO 6M100X20 VITE SCREW	SCHRAUBE VIS	1 2	
13A		00G05900711	CASQUILLO FIJ. CARCASA SUPERIOR GHIERA BUSH	DISTANZHULSE ENTRETOISE	1 2	
14A		00D01501371	TUERCA FIJACION D6 DADO NUT	MUTTER ECROU	1 2	
15A		00G01506751	CUPULA CARCASA COPERCHIO COVER	DECKEL COUVERCLE	1 2	
16A		00012051200	TORNILLO C/REDONDA CRUZ 5M80X12 VITE SCREW	SCHRAUBE VIS	1 2	
17A		00G04401462	TUERCA FIJACION D5 DADO NUT	MUTTER ECROU	1 2	
18A		00011031001	TORNILLO AUTORROSCANTE 3,6X10 VITE SCREW	SCHRAUBE VIS	1 2	
19A		864097	CTO.TABLIER (KPH) CRUSCOTTO (KMH) DASH ASSY (KMH)	INSTRUMENTERHALTER (KMH) BOITIER TABLEAU BORD (KMH)		KILOMETERS PER HOUR
19B		864185	CTO.TABLIER (MPH) CRUSCOTTO (MPH) DASH ASSY (MPH)	INSTRUMENTERHALTER (MPH) BOITIER TABLEAU BORD (MPH)		MILES PER HOUR
20A		00011941300	TORNILLO AUTORROSCANTE VITE SCREW	SCHRAUBE VIS	1 2	
21A		00D02600631	ARANDELA RONDELLA WASHER	SCHEIBE RONDELLE	1 2	

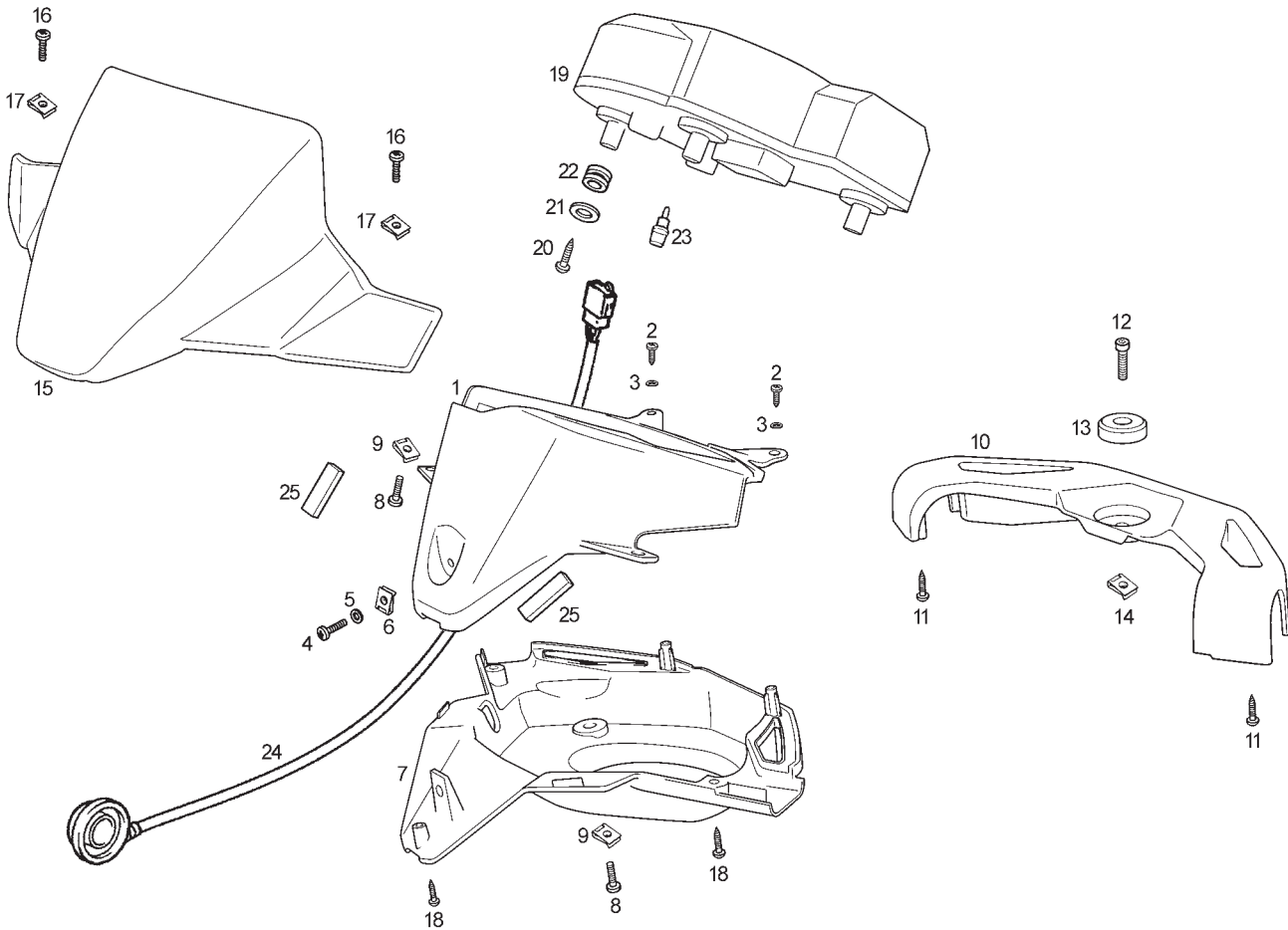

Fig.	Ver.	COD. KOD.	DESCRIPCIÓN DENOMINAZIONE NAME	BEZEICHNUNG DESIGNATION	MOD.	NOTAS NOTES NOTA MITSCHRIFT NOTES
22A		00H01602941	SILENTBLOCK PASSACAVO GROMMET	KABELDURCHGANG PASSE-CÂBLE	1 2	
23A		00G01602581	BOMBILLA TABLIER 12V 1,2W LAMPADA BULB	BIRNE AMPOULE	1 2	
24A		86108R	CTO.REENVIO CTAKMS RINVIO RETURN UNIT.	RETURN UNIT. RENVOI DE ROUE	1 2	
25A		864568	TOPE ANTIVIBRACION FERMO STOPPER	ANSCHLAG BUTÉE	1 2	

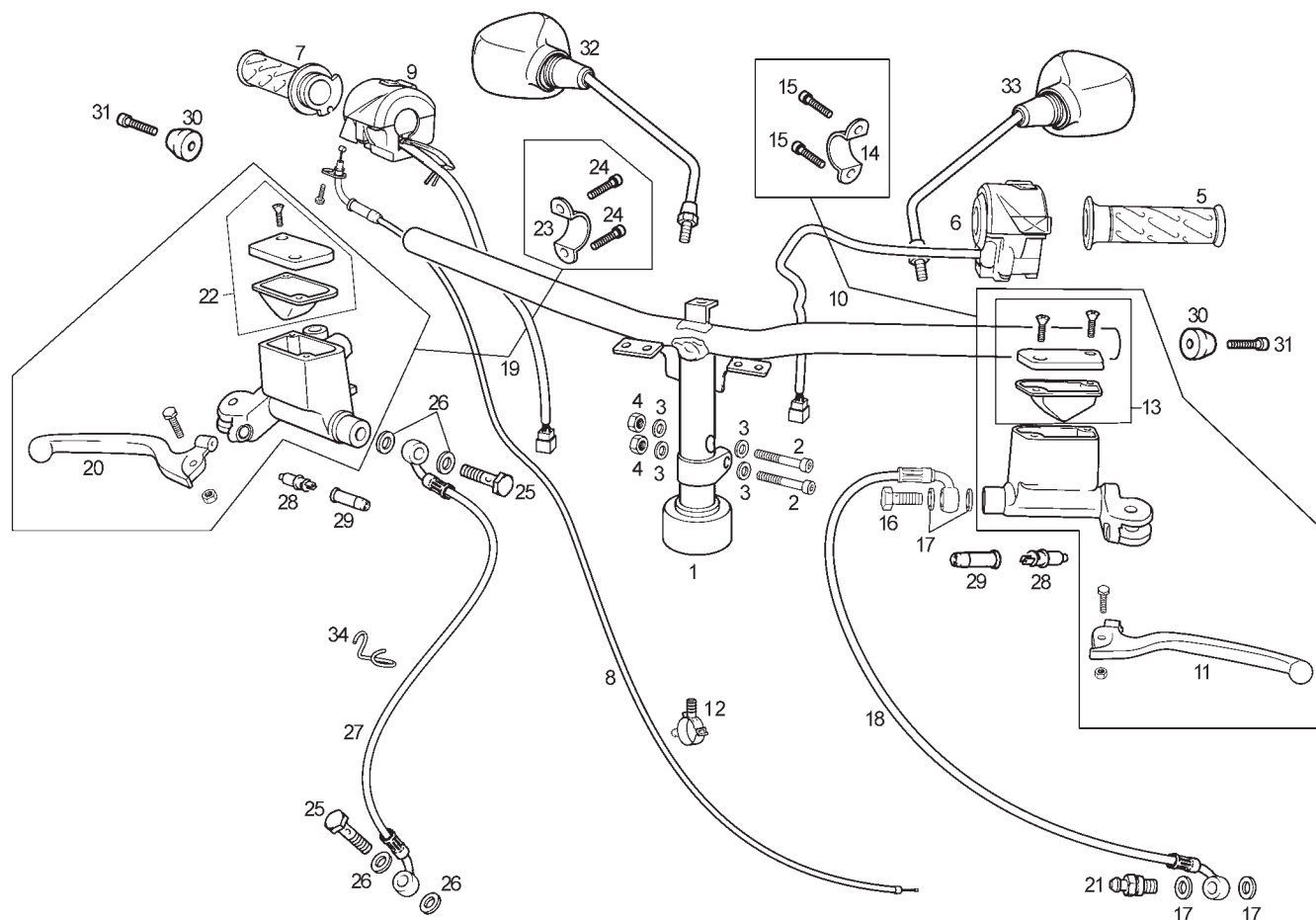

Fig.	Ver.	COD. KOD.	DESCRIPCIÓN DENOMINAZIONE NAME	BEZEICHNUNG DESIGNATION	MOD.	NOTAS NOTES NOTA MITSCHRIFT NOTES
01A		00G00910011	MANILLAR MANUBRIO HANDLEBAR	LENKER GUIDON	1 2	
02A		00004184500	TORNILLO C/ALLEN 8M125X45 VITE SCREW	SCHRAUBE VIS	1 2	
03A		00000031080	ARANDELA PLANA D8 RONDELLA WASHER	SCHEIBE RONDELLE	1 2	
04A		00000023080	TUERCA AUTOBLOCANTE 8M125 DADO NUT	MUTTER ECROU	1 2	
05A		00G00909071	EMPUÑADURA IZQUIERDA MANOPOLA GRIP	GRIFFGUMMI POIGNEE FREIN	1 2	
06A		00G02304171	CONMUTADOR LUCES CONMUTATORE LUCI SWITCH	LICHTSCHALTER INVERSEUR AVEC CABLE	1 2	
07A		00G00910081	PUÑO GAS MANOPOLA ACCELERATO THROTTLE TWIST GRIP ASSY	GASGRIFF KOMPL. ENSEMBLE POIGNEE GAZ	1 2	
08A		864098	CTO CABLE GAS CAVO ACCELERATORE THROTTLE CABLE	GASKABEL CABLE GAZ	1 2	
09A		00G02102631	CONMUTADOR ARRANQUE ELECTRICO INTERRUPTORE SWITCH	STOPSCHALTER INTERRUPTEUR	1 2	
10A		862556	CTO BOMBA FRENO TRASERO BOMBA FRENO BRAKE PUMP	BREMSPUMPE POMPE DE FREIN	1 2	

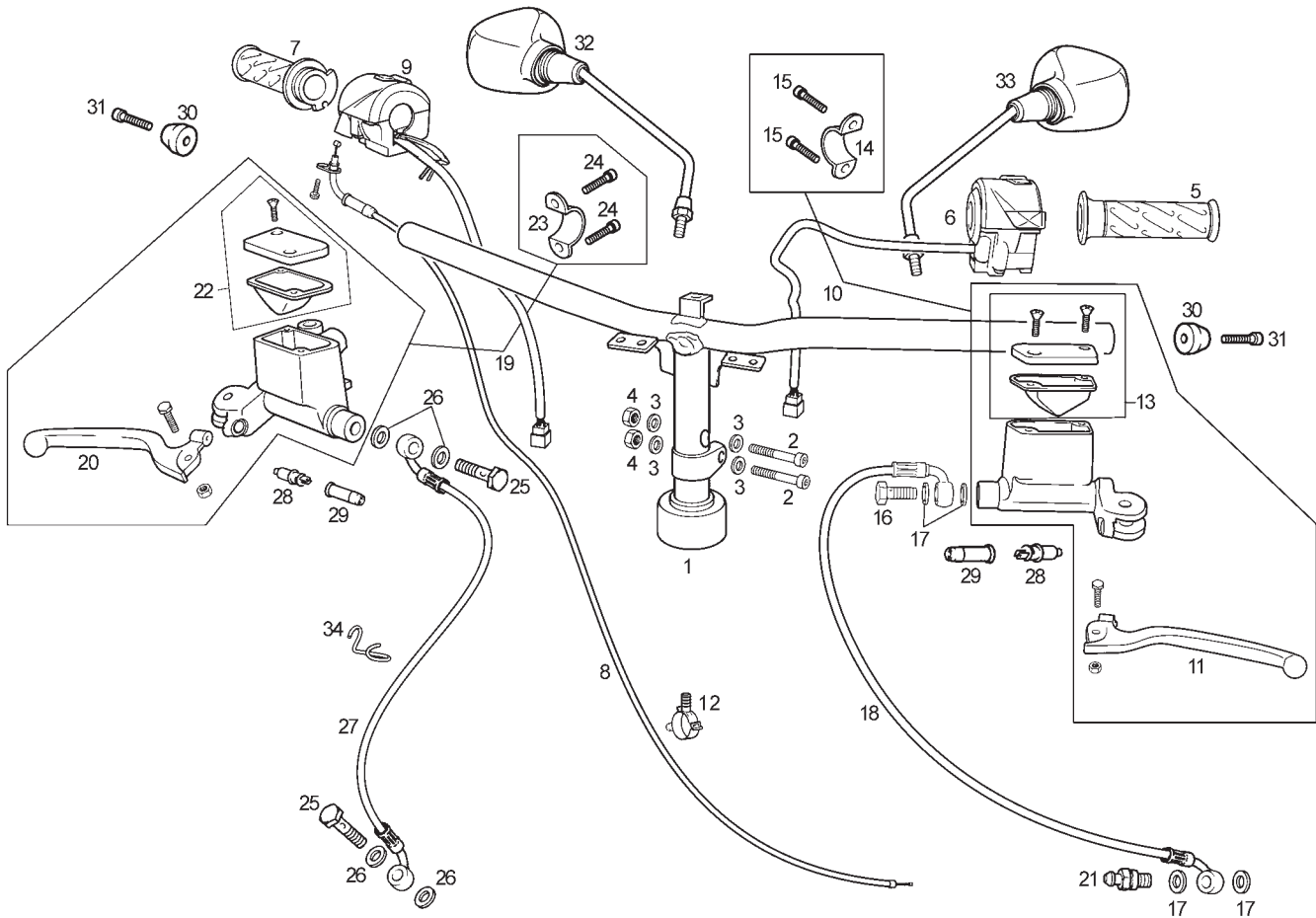

Fig.	Ver.	COD. KOD.	DESCRIPCIÓN DENOMINAZIONE NAME	BEZEICHNUNG DESIGNATION	MOD.	NOTAS NOTES NOTA MITSCHRIFT NOTES
11A		00G00903201	MANETA FRENO LEVIER FRENO BRAKE LEVER	BREMSHEBEL FREIN D'EMBRAYAGE	1 2	
12A		863553	BRIDA PASACABLES FLANGIA CLAMP	BINDER COLLIER	1 2	
13A		00G05601201	KIT REPAR.TAPA BOMBA FRENO TRAS KIT COPERCHIO COVER KIT	DECKEL KIT COUVERCLE KIT	1 2	
14A		00H02100901	BRIDA FIJACION BOMBA FRENO FLANGIA CLAMP	BINDER COLLIER	1 2	
15A		00000004512	TORNILLO FIJACION BRIDA VITE SCREW	SCHRAUBE VIS	1 2	
16A		00006309260	RACORD HIDRAULICO RACCORDO TUBE CONNECTOR	STUTZEN HYDRAULIKLEITUNG RACCORD	1 2	
17A		00006321040	ARANDELA RACORD RONDELLA WASHER	SCHEIBE RONDELLE	1 2	
18A		864581	TUBO LIQUIDO FRENOS TRASERO TUBO TUBE	SCHLAUCH TUYAU	1 2	
19A		861669	CTO BOMBA FRENO DELANTERO BOMBA FRENO BRAKE PUMP	BREMSPUMPE POMPE DE FREIN	1 2	
20A		00G00903201	MANETA FRENO LEVIER FRENO BRAKE LEVER	BREMSHEBEL FREIN D'EMBRAYAGE	1 2	

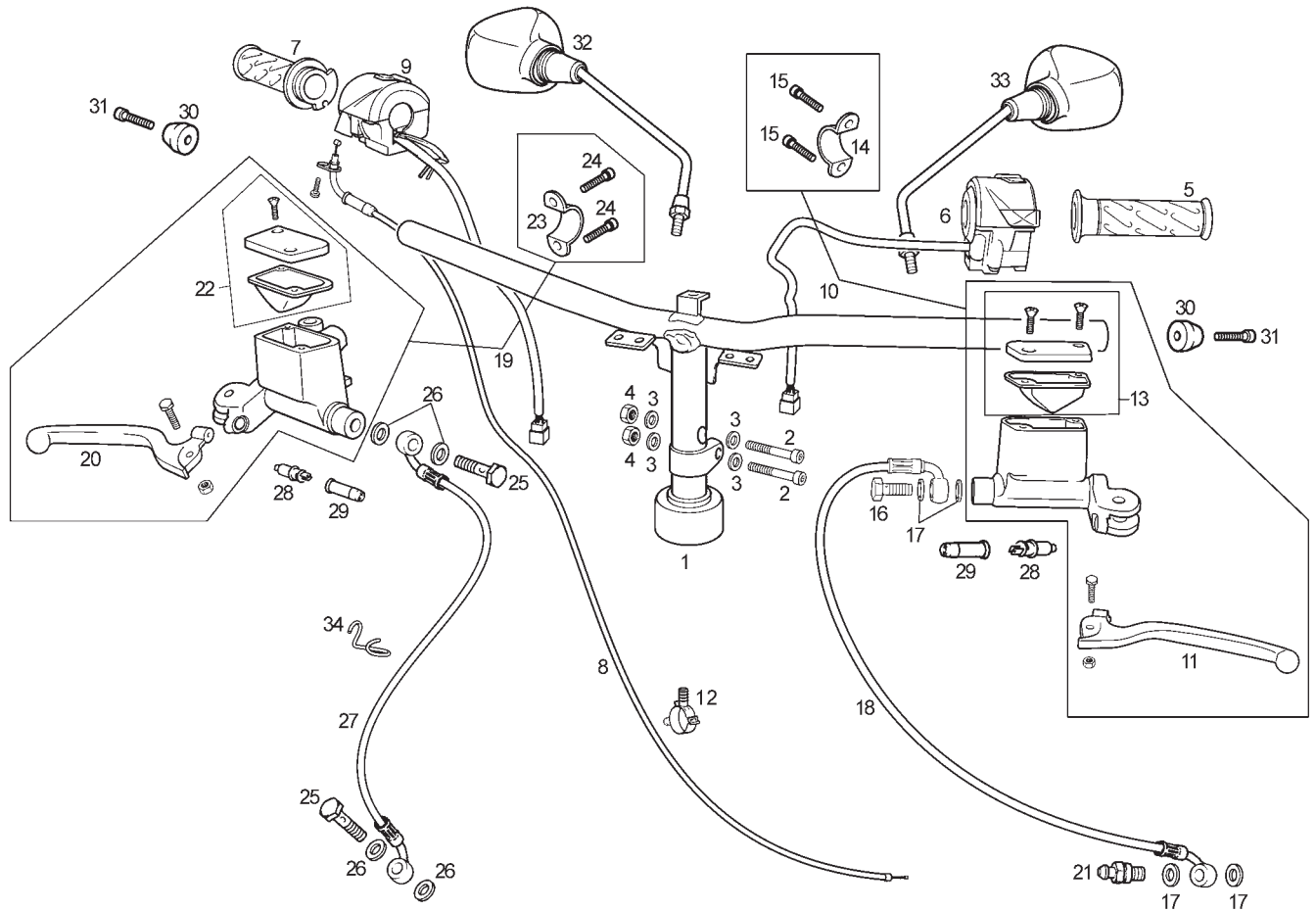

Fig.	Ver.	COD. KOD.	DESCRIPCIÓN DENOMINAZIONE NAME	BEZEICHNUNG DESIGNATION	MOD.	NOTAS NOTES NOTA MITSCHRIFT
21A		00H04702121	RACORD HIDRAULICO C/SANGRADOR RACCORDO TUBE CONNECTOR	STUTZEN HYDRAULIKLEITUNG RACCORD	1 2	
22A		862534	KIT REPARACION TAPA BOMBA FRENO DT KIT COPERCHIO COVER KIT	DECKEL KIT COUVERCLE KIT	1 2	
23A		00H02100901	BRIDA FIJACION BOMBA FRENO FLANGIA CLAMP	BINDER COLLIER	1 2	
24A		00000004512	TORNILLO FIJACION BRIDA VITE SCREW	SCHRAUBE VIS	1 2	
25A		00006309260	RACORD RACCORDO TUBE CONNECTOR	STUTZEN HYDRAULIKLEITUNG RACCORD	1 2	
26A		00006321040	ARANDELA RACORD RONDELLA WASHER	SCHEIBE RONDELLE	1 2	
27A		864578	TUBO LIQUIDO FRENOS DELANTERO TUBO TUBE	SCHLAUCH TUYAU	1 2	
28A		AP8127305	INTERRUPTOR STOP GP1 LS INTERRUPTORE COMANDO STOP SWITCH, STOP LIGHT	STOPSCHALTER VO. INTERRUPTEUR COMMANDEMENT STOP	1 2	
29A		00005010760	CAPUCHON INTERRUPTOR STOP CAPPuccio CAVO CABLE PROTECTOR	KAPPE BOUCHON	1 2	
30A		86446200W07	CONTRAPESO MANILLAR CONTRAPPESO MANOPOLA HANDLEBAR COUNTERWEIGHT	GEGENGEWICHT DES LENKERS CONTRE POIDS DE GUIDON	1 2	

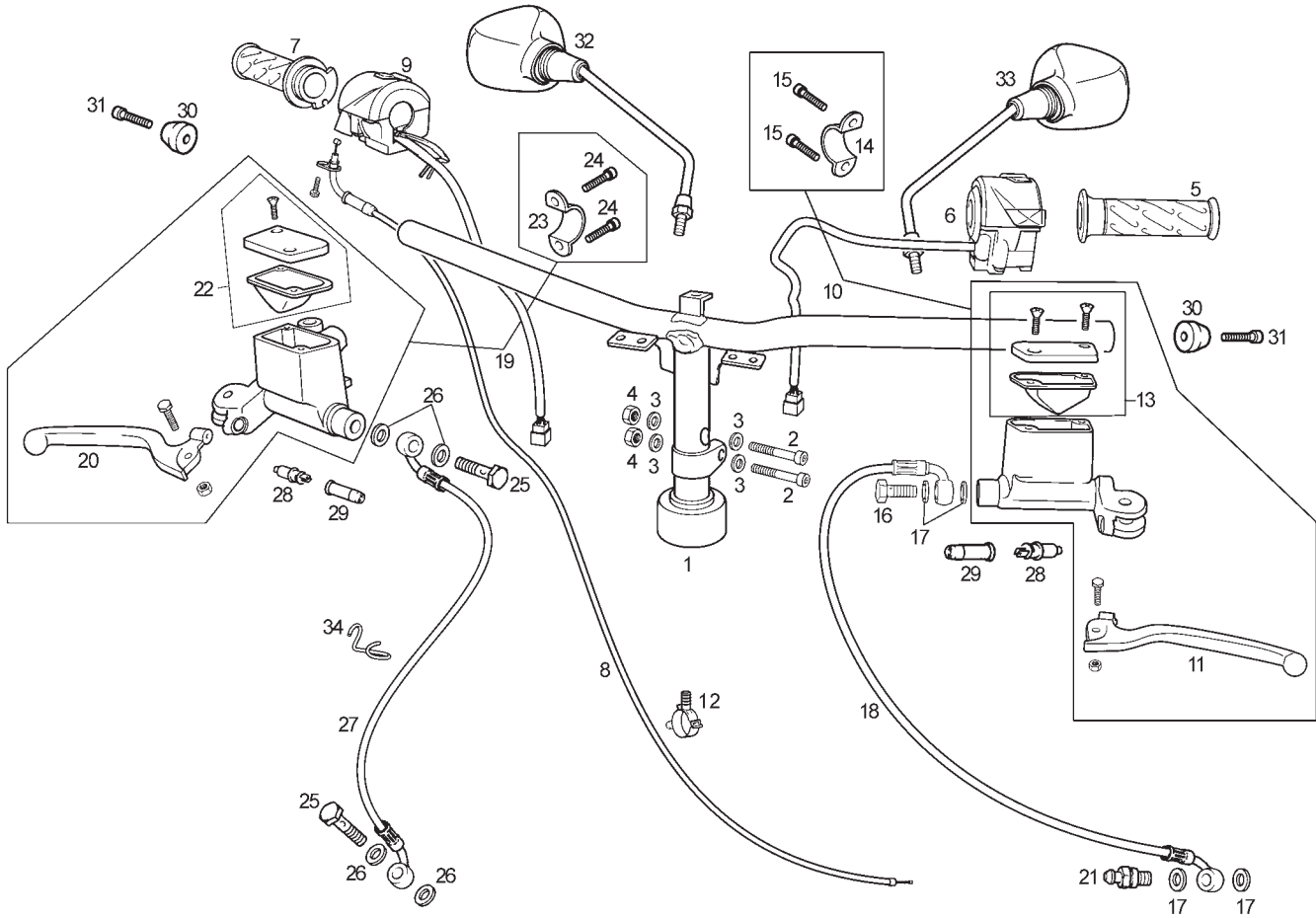

Fig.	Ver.	COD. KOD.	DESCRIPCIÓN DENOMINAZIONE NAME	BEZEICHNUNG DESIGNATION	MOD.	NOTAS NOTES NOTA MITSCHRIFT NOTES
31A		00004154000	TORNILLO C/ALLEN 5M80X40 VITE SCREW	SCHRAUBE VIS	1 2	
32A		863712	ESPEJO RETROVISOR DERECHO SPECCHIETTO RETROVSORE DX RH. REAR VIEW MIRROR	RECHT SPIEGEL RETROVISEUR DR.	1 2	
33A		863713	ESPEJO RETROVISOR IZQUIERDO SPECCHIETTO RETROVSORE SX LH. REAR VIEW MIRROR	SPIEGEL LINKE RETROVISEUR GA.	1 2	
34A		00F01500381	MUELLE GUIA CABLES MOLLA SPRING	FEDER RESSORT	1 2	

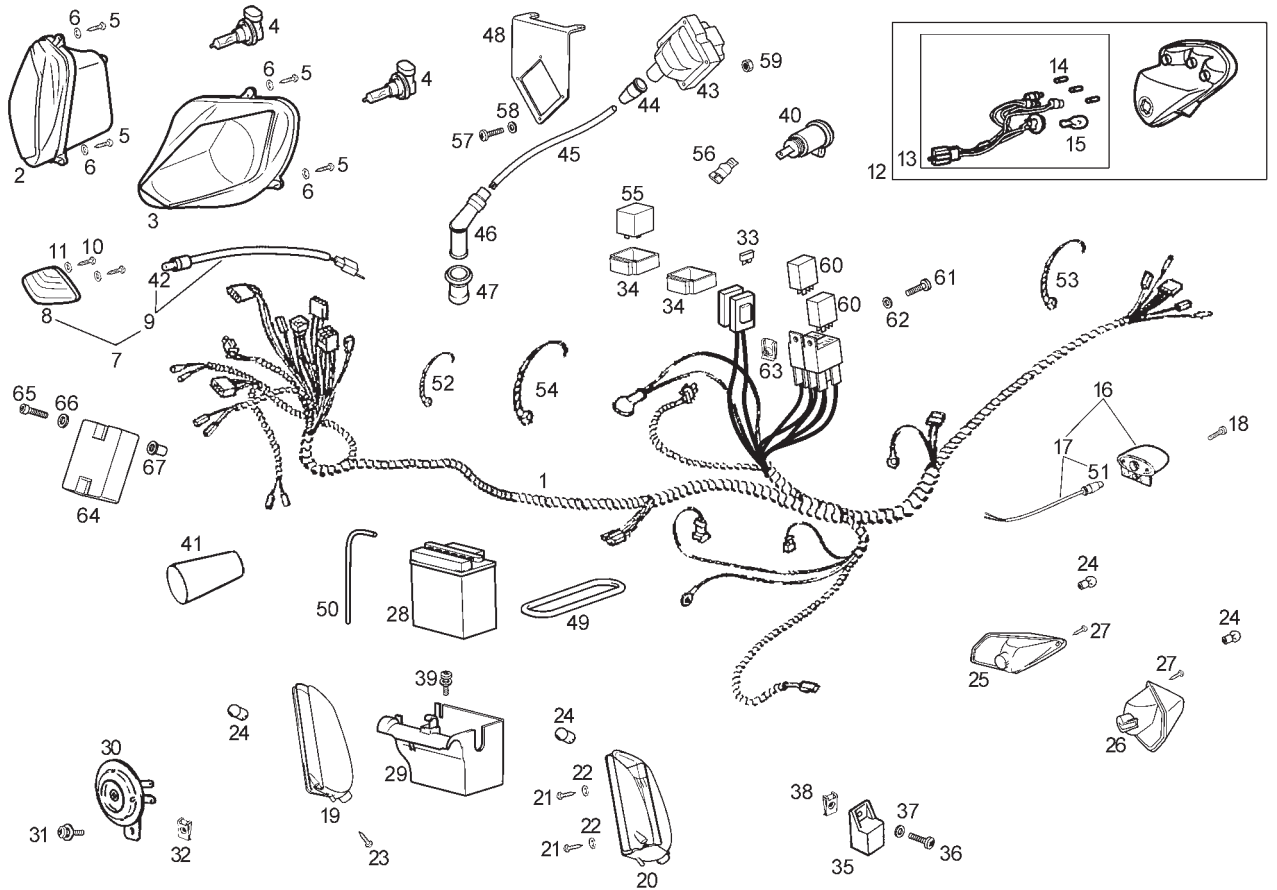

Fig.	Ver.	COD. KOD.	DESCRIPCIÓN DENOMINAZIONE NAME	BEZEICHUNG DESIGNATION	MOD.	NOTAS NOTES NOTA MITSCHRIFT NOTES
01A		863808	INSTALACION ELECTRICA IMPIANTO ELETTRICO ELECTRICAL INSTALATIONS	ELEKTROINSTALLATION FAISCEAU ELECTRIQUE	1 2	
02A		00H01023011	FARO DT DERECHO (H11) GR. OTTICO DX. RH LIGHT UNIT	RE. SCHEINWERFER OPTIQUE DR.	1 2	
02B		00G01026011	FARO DT DERECHO (H8) GR. OTTICO DX. RH LIGHT UNIT	RE. SCHEINWERFER OPTIQUE DR.	1 2	ONLY ENGLAND JAPAN
03A		00H01024011	FARO DT IZQUIERDO (H11) GR. OTTICO SX. LH LIGHT UNIT	LI. SCHEINWERFER OPTIQUE GA.	1 2	
03B		00G01027011	FARO DT IZQUIERDO (H8) GR. OTTICO SX. LH LIGHT UNIT	LI. SCHEINWERFER OPTIQUE GA.	1 2	ONLY ENGLAND JAPAN
04A		00H01002131	BOMBILLA H11 55W LAMPADA BULB	BIRNE AMPOULE	1 2	
04B		00H01004131	BOMBILLA H8 35W LAMPADA BULB	BIRNE AMPOULE	1 2	ONLY ENGLAND JAPAN
05A		00011031401	TORNILLO AUTOROSCANTE 3,6X14 VITE SCREW	SCHRAUBE VIS	1 2	
06A		00000031050	ARANDELA PLANA D5 RONDELLA WASHER	SCHEIBE RONDELLE	1 2	
07A		00H05704471	FARO LUZ POSICION FANALINO POSICIONE POSITION LIGHT ASSY	LICHT IN POSITION LUMIERE DE POSITION	1 2	
08A		00H05701471	OPTICA LUZ POSICION FANALINO GLASS	LICHT FEU	1 2	

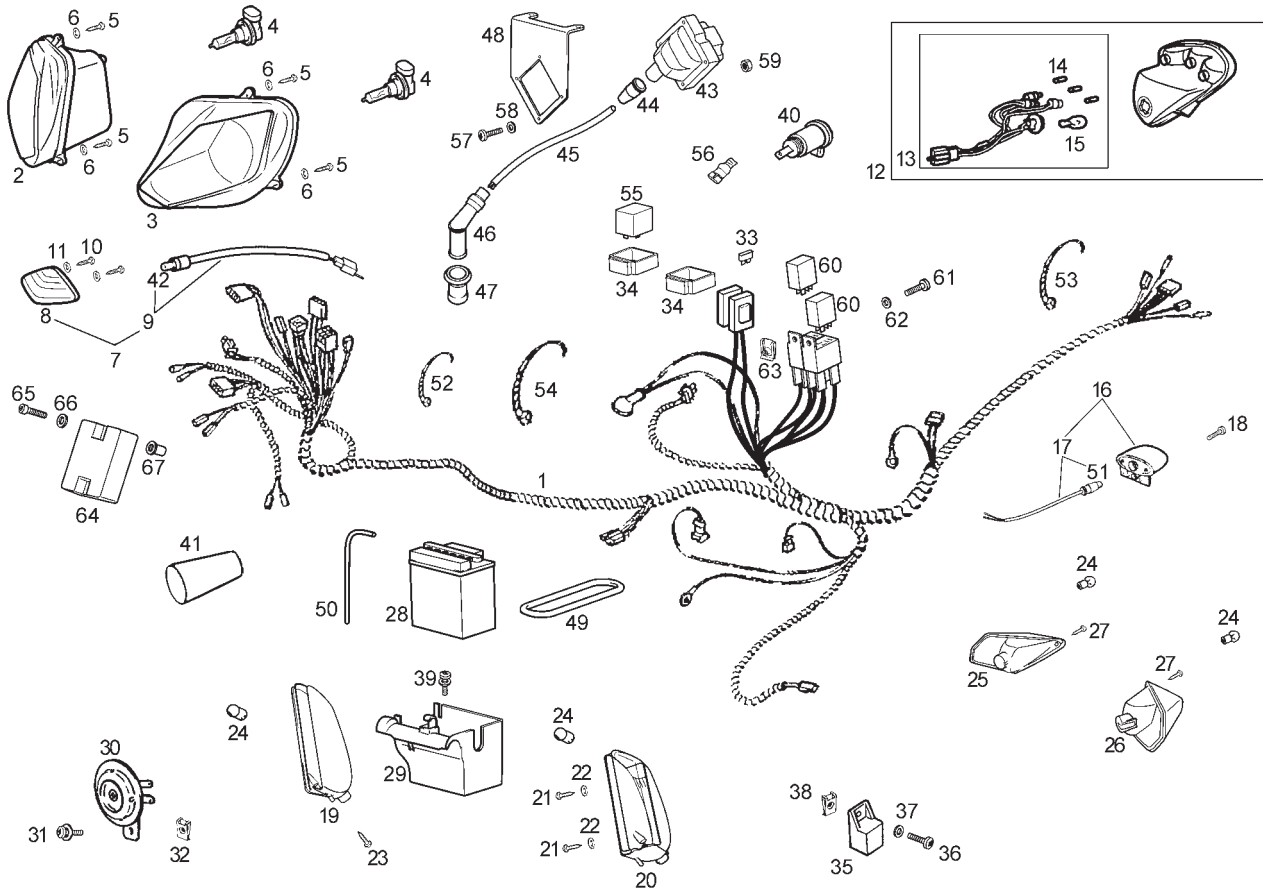

Fig.	Ver.	COD. KOD.	DESCRIPCIÓN DENOMINAZIONE NAME	BEZEICHNUNG DESIGNATION	MOD.	NOTAS NOTES NOTA MITSCHRIFT NOTES
09A		00H05703471	CTO LAMPARA-PORTALAMPARA LAMPADA BULB	LAMPE TUBE PHARES	1 2	
10A		00011031401	TORNILLO AUTOROSCANTE 3,6X14 VITE SCREW	SCHRAUBE VIS	1 2	
11A		00D02600631	ARANDELA RONDELLA WASHER	SCHEIBE RONDELLE	1 2	
12A		00H01011321	FARO PILOTO FANALINO POSTERIORE TAILLIGHT ASSY.	GRUPPE RICKLICHT FEU ARRIERE	1 2	
13A		00H01003951	CTO INSTALACION FARO PILOTO IMPIANTO FANALINO POSTERIORE TAILLIGHT EQUIPMENT	GR. RICKLICHT ELEKTROINSTALLATION FAISCEAU FEU ARRIERE	1 2	
14A		00H01001371	BOMBILLA POSICION 12V 2,3W LAMPADA BULB	BIRNE AMPOULE	1 2	
15A		00H01000681	BOMBILLA FRENO PILOTO 12V 16W LAMPADA BULB	BIRNE AMPOULE	1 2	
16A		00G05701471	FARO ILUMINACION MATRICULA IMPIANTO ELETRICO ELECTRICAL INSTALATIONS	ELEKTROINSTALLATION FAISCEAU ELECTRIQUE	1 2	
17A		00G02300581	CTO LAMPARA-PORTALAMPARA LAMPADA BULB	LAMPE TUBE PHARES	1 2	
18A		00011031401	TORNILLO AUTOROSCANTE 3,6X14 VITE SCREW	SCHRAUBE VIS	1 2	
19A		00G01706021	INTERMITENTE DELANTERO DERECHO FARO INDICATORE INDICATOR LIGHT	BLINKER CLIGNOTANT	1 2	

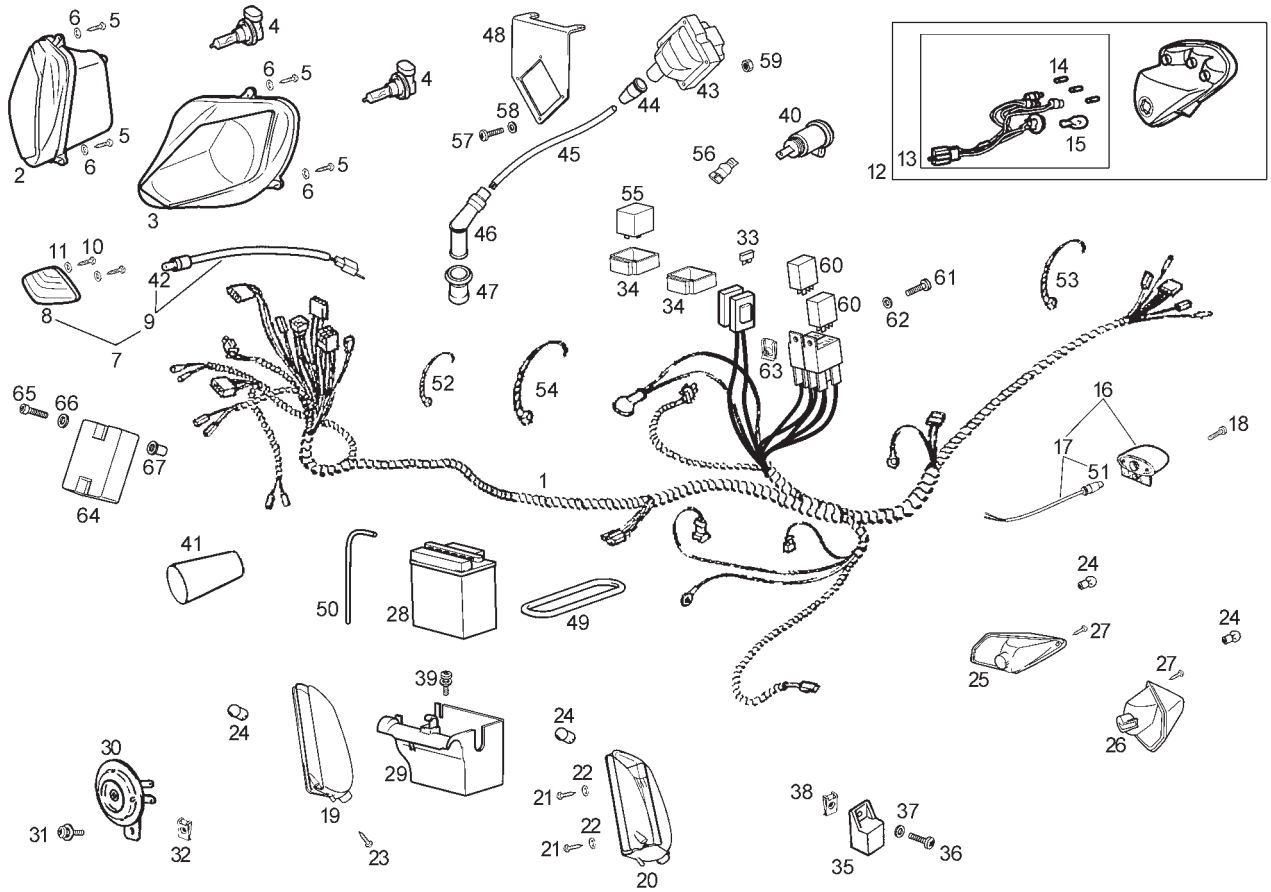

Fig.	Ver.	COD. KOD.	DESCRIPCIÓN DENOMINAZIONE NAME	BEZEICHUNG DESIGNATION	MOD.	NOTAS NOTES NOTA MITSCHRIFT NOTES
20A		00G01706311	INTERMITENTE DELANTERO IZQUIERDO FARO INDICATORE INDICATOR LIGHT	BLINKER CLIGNOTANT	1 2	
21A		00112031060	TORNILLO AUTOROSCANTE 3X10 VITE SCREW	SCHRAUBE VIS	1 2	
22A		00402030001	ARANDELA D3,7 RONDELLA WASHER	SCHEIBE RONDELLE	1 2	
23A		00112031560	TORNILLO AUTOROSCANTE 3X15 VITE SCREW	SCHRAUBE VIS	1 2	
24A		00H01701011	BOMBILLA INTERMITENTE NARANJA LAMPADA BULB	BIRNE AMPOULE	1 2	
25A		00G01700531	INTERMITENTE TRASERO DERECHO FARO INDICATORE INDICATOR LIGHT	BLINKER CLIGNOTANT	1 2	
26A		00G01700541	INTERMITENTE TRASERO IZQUIERDO FARO INDICATORE INDICATOR LIGHT	BLINKER CLIGNOTANT	1 2	
27A		00112031560	TORNILLO AUTOROSCANTE 3X15 VITE SCREW	SCHRAUBE VIS	1 2	
28A		00G03304401	BATERIA 12V 12AMP BATERIA BATTERY	BATTERIE BATTERIE	1 2	
29A		863711	CAJA BATERIA SCATOLA BOX	KASTEN BOITE	1 2	
30A		294828	CLAXON CLACSON HORN	HUPE AVERTISSEUR	1 2	



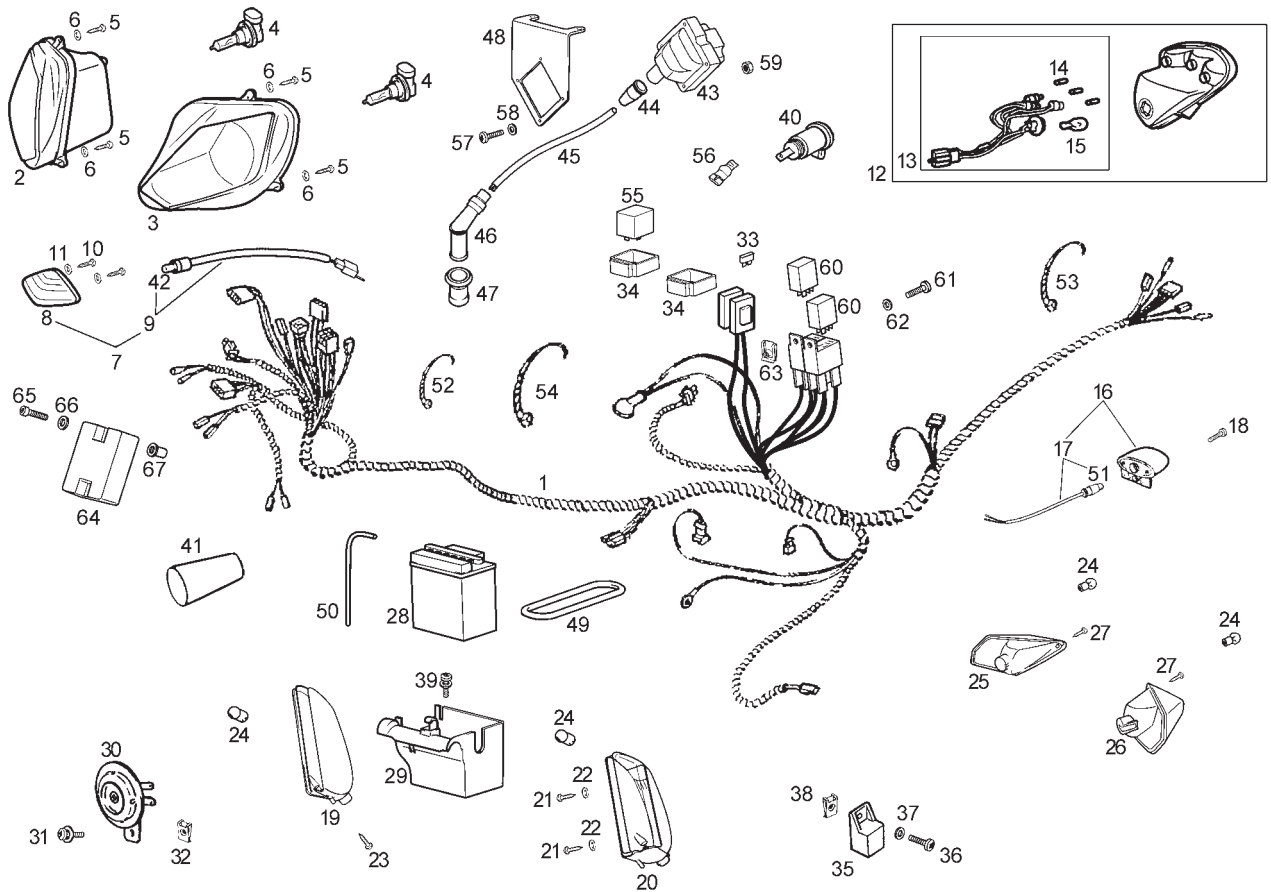

Fig.	Ver.	COD. KOD.	DESCRIPCIÓN DENOMINAZIONE NAME	BEZEICHUNG DESIGNATION	MOD.	NOTAS NOTES NOTA MITSCHRIFT NOTES
41A		00H02300961	PROTECCION CONEXIONES CAPPUCCIO RUBBER COVER	GUMMISCHUTZ CAPUCHON	1 2	
42A		00H01003131	BOMBILLA LUZ POSICION 12V 5W LAMPADA BULB	BIRNE AMPOULE	1 2	
43A		58120R	BOBINA BOBINA IGNITION COIL	SPULE BOBINE	1 2	
44A		071671	CAPUCHON CABLE CAPPUCCIO PROTECTOR	KAPPE CACHE	1 2	
45A		863902	CABLE BOBINA DE ALTA CAVO CABLE	KABEL CABLE	1 2	
46A		293845	PIPA BUJIA PIPETA CANDELA PLUG CAP ASSY	ZUNDKERZENSTECRER PIPE DE BOUGIE	1 2	
47A		436919	PROTECTOR PIPA BUJIA CAPPUCCIO PROTECTOR	KAPPE CACHE	1 2	
48A		863842	CARTELA FIJACION BOBINA SUPPORTO BRACKET	HALTERUNG SUPPORT	1 2	
49A		00G01802361	ANILLO TORICO BATERIA ANELLO O'RING	RING CIRCLIPS	1 2	
50A		00H04402601	TUBO DESVAPORIZADOR BATERIA TUBO TUBE	SCHLAUCH TUYAU	1 2	
51A		00H01003131	BOMBILLA 12V 5W LAMPADA BULB	BIRNE AMPOULE	1 2	

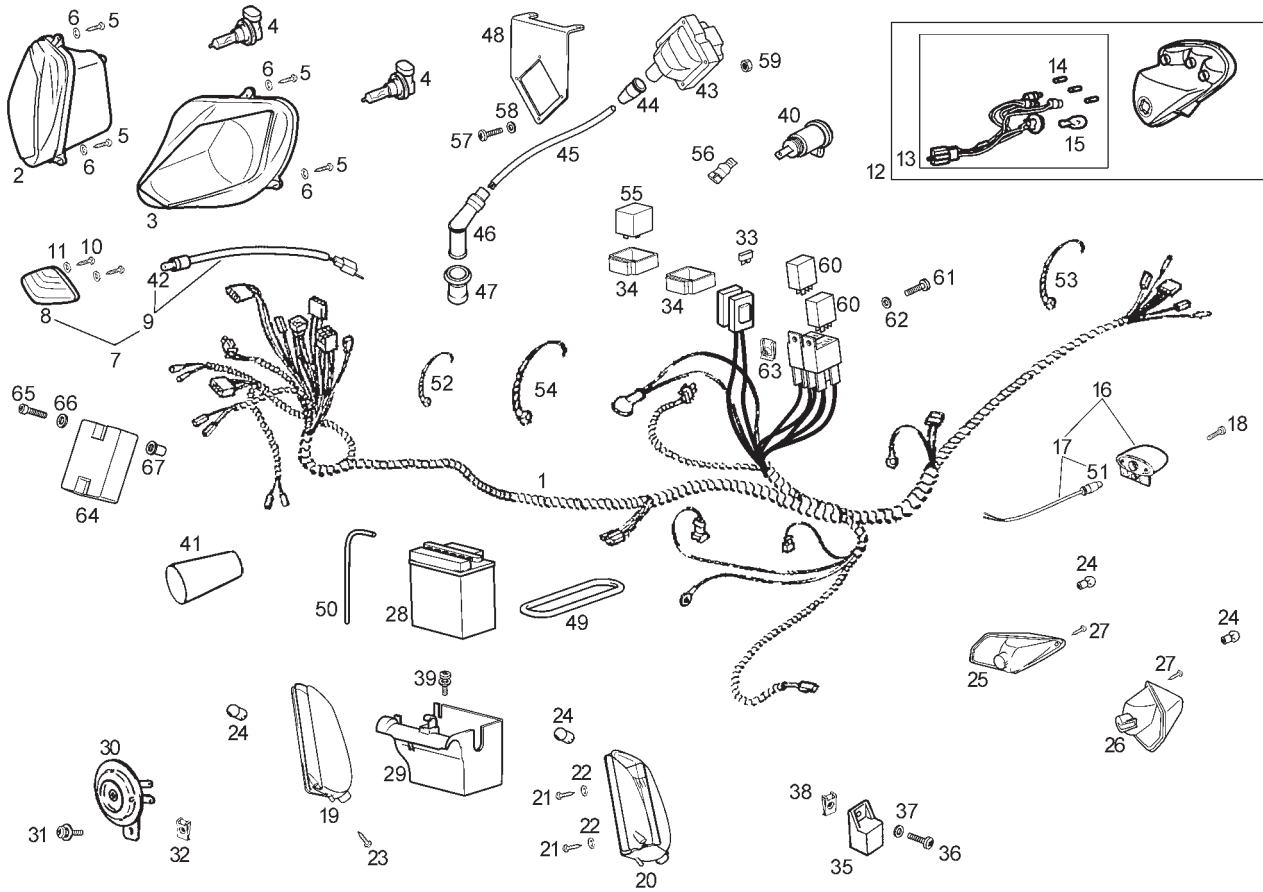

Fig.	Ver.	COD. KOD.	DESCRIPCIÓN DENOMINAZIONE NAME	BEZEICHNUNG DESIGNATION	MOD.	NOTAS NOTES NOTA MITSCHRIFT NOTES
52A		00A00900531	BRIDA 140 X 3,6 FLANGIA CLAMP	BINDER COLLIER	1 2	
53A		00D00900531	BRIDA 200 X 3,6 FLANGIA CLAMP	BINDER COLLIER	1 2	
54A		00F00900531	BRIDA 290 X 4,8 FLANGIA CLAMP	BINDER COLLIER	1 2	
55A		861250	CTO CENTRAL INTERMITENTES TELERUTTORE RELAY	FERNSCHALTER RELAIS	1 2	
56A		00G02301991	DIODO DIODO DIODE	DIODE DIODE	1 2	
57A		863904	TORNILLO C/RED CRUZ 3MX25 VITE SCREW	SCHRAUBE VIS	1 2	
58A		863905	ARANDELA ESTRELLA D3 RONDELLA WASHER	SCHEIBE RONDELLE	1 2	
59A		00000021030	TUERCA EXAGONAL 3M50 DADO NUT	MUTTER ECROU	1 2	
60A		00N05700711	RELE TELERUTTORE RELAY	FERNSCHALTER RELAIS	1 2	
61A		00000004515	TORNILLO C/ALLEN 5M80X15 VITE SCREW	SCHRAUBE VIS	1 2	
62A		00000031050	ARANDELA D5 RONDELLA WASHER	SCHEIBE RONDELLE	1 2	

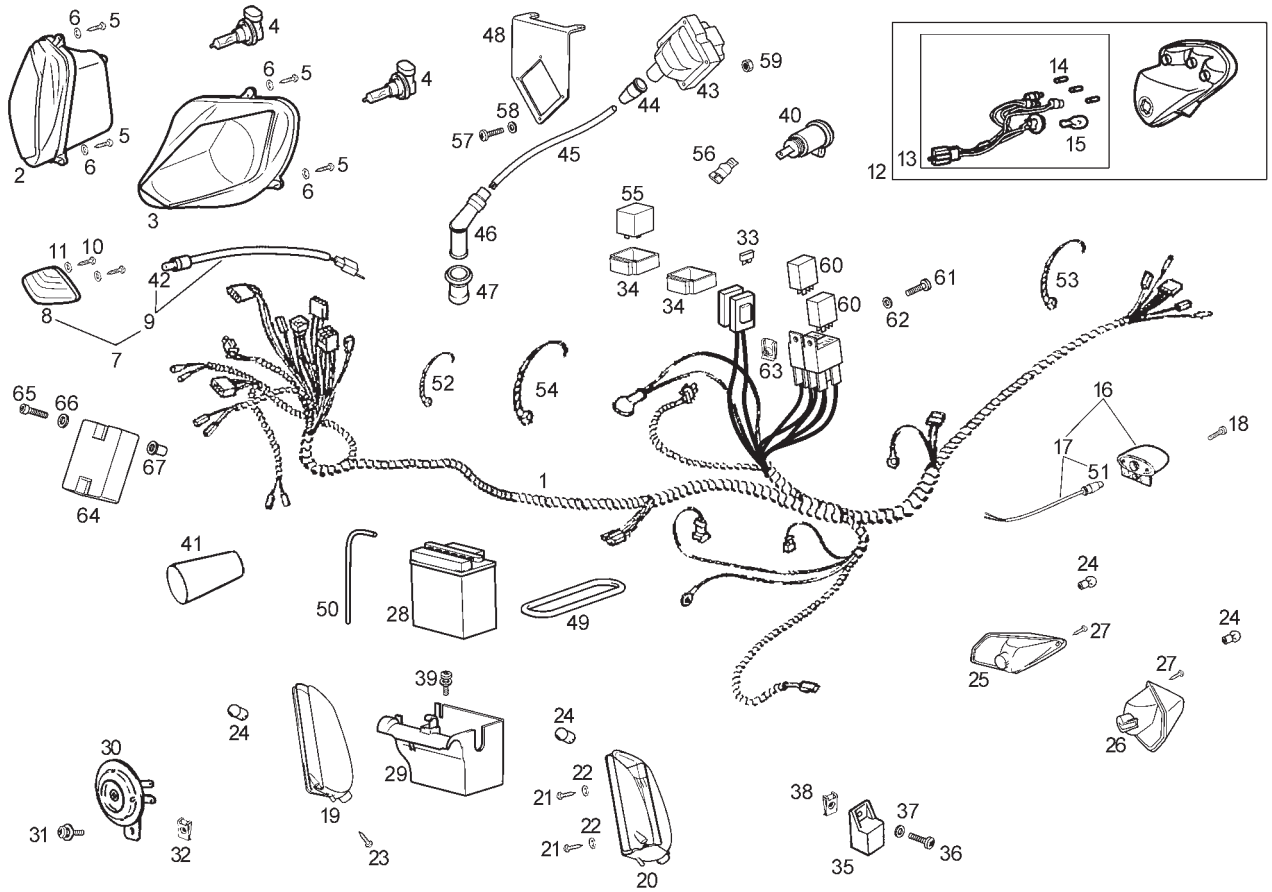

Fig.	Ver.	COD. KOD.	DESCRIPCIÓN DENOMINAZIONE NAME	BEZEICHNUNG DESIGNATION	MOD.	NOTAS NOTES MITSCHRIFT
63A		00H01500691	TUERCA FIJACION D5 DADO NUT	MUTTER ECROU	1 2	
64A		584533	REGULADOR REGOLATORE REGULATOR	REGLER REGULATEUR	1 2	
65A		00000004635	TORNILLO C/ALLEN 6M100X35 VITE SCREW	SCHRAUBE VIS	1 2	
66A		00402060001	ARANDELA D6 RONDELLA WASHER	SCHEIBE RONDELLE	1 2	
67A		00H04400711	TUERCA RIVKLE M6 DADO NUT	MUTTER ECROU	1 2	

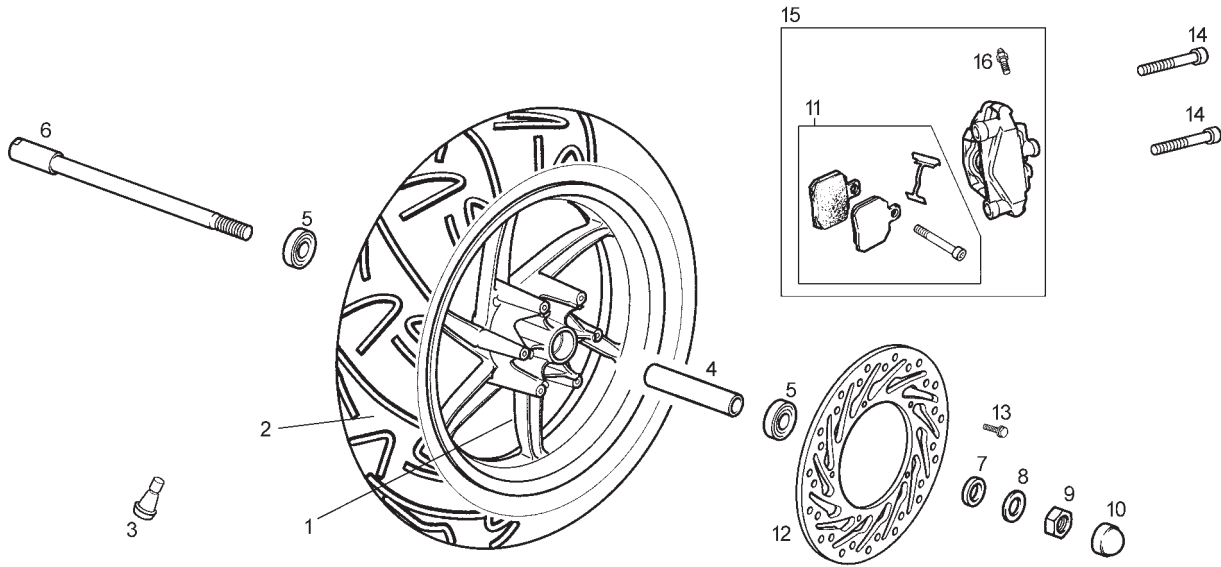

Fig.	Ver.	COD. KOD.	DESCRIPCIÓN DENOMINAZIONE NAME	BEZEICHNUNG DESIGNATION	MOD.	NOTAS NOTES NOTA MITSCHRIFT NOTES
01A		863178	CTO LLANTA DELANTERA CERCHIO ANTERIORE FRONT WHEEL	FELGE VORNE JANTE DE DEVANT	1 2	
02A		00G01215111	CUBIERTA DELANTERA 120/70-14" COPERTONE TYRE	REIFEN PNEU	1 2	
03A		00G04702091	VALVULA AIRE VALVOLA ARIA VALVE, TYRE	LUFTVENTIL RAEDER SOUPAPE D'ADMISSION D'AIR	1 2	
04A		959378	SEPARADOR COJINETES GHIERA BUSH	DISTANZHULSE ENTRETOISE	1 2	
05A		327187	COJINETE CUSCINETTO BEARING	LAGER ROULEMENT	1 2	
06A		863181	EJE RUEDA DELANTERA ASSE RUOTA ANTERIORE FRONT WHEEL AXLE	VORDERRADACHSE AXE ROUE AVANT	1 2	
07A		00G01201291	CASQUILLO SEPARADOR RUEDA DT GHIERA BUSH	DISTANZHULSE ENTRETOISE	1 2	
08A		00032015000	ARANDELA PLANA D15 RONDELLA WASHER	SCHEIBE RONDELLE	1 2	
09A		00H00300672	TUERCA CABEZA EJE RUEDA DADO NUT	MUTTER ECROU	1 2	
10A		00H01201331	PROTECTOR TUERCA EJE PROTEZIONE PROTECTOR	ABDECKUNG PROTECTEUR	1 2	
11A		864580	KIT COMPONENTES PASTILLAS FRENO DT CONG. PASTIGLIE FRENO SET OF BRAKE PADS	DIE GESAMTHEIT BREMSBACKEN ENS. PLAQUETTE DE FREIN	1 2	

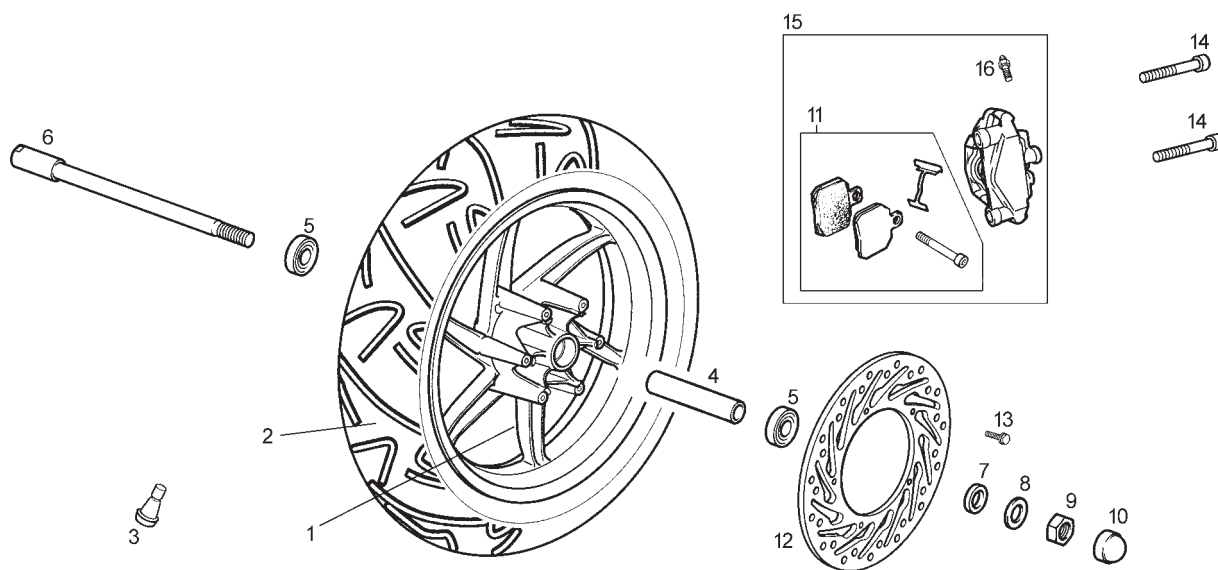

Fig.	Ver.	COD. KOD.	DESCRIPCIÓN DENOMINAZIONE NAME	BEZEICHNUNG DESIGNATION	MOD.	NOTAS NOTES NOTA MITSCHRIFT NOTES
12A		863180	DISCO FRENO DELANTERO DISCO FRENO FRONT BRAKE DISC	BREMSSSCHEIBE VORNE DISQUE DE FREIN AVANT	1 2	
13A		00052062011	TORNILLO 6M100X20 VITE SCREW	SCHRAUBE VIS	1 2	
14A		00000004160	TORNILLO C/ALLEN 10M150X60 VITE SCREW	SCHRAUBE VIS	1 2	
15A		864579	CTO PINZA FRENO DELANTERO COMPL.PINZA ANTERIORE BRAKE CALIPER	BREMSZANGE VORNE ENSEMBLE PINCE FREIN	1 2	
16A		00H04705121	CTO KIT SANGRADOR SPURGO BLEED	ENTLUFTUNGSVENTIL EPURATEUR	1 2	

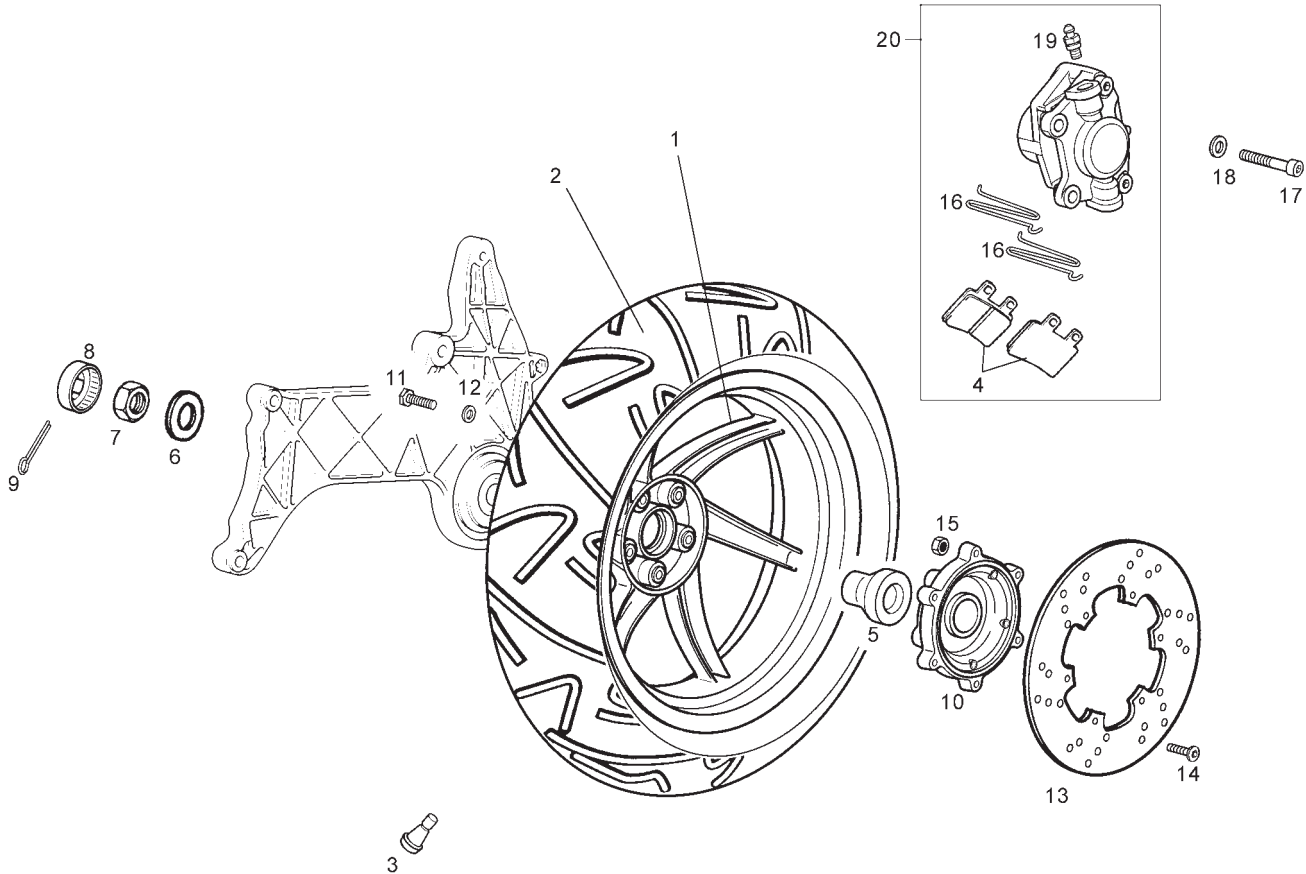

Fig.	Ver.	COD. KOD.	DESCRIPCIÓN DENOMINAZIONE NAME	BEZEICHNUNG DESIGNATION	MOD.	NOTAS NOTES NOTA MITSCHRIFT NOTES
01A		949357	LLANTA TRASERA CERCHIONE POSTERIORE REAR RIM	HINTERRAD JANTE ARRIERE	1 2	
02A		86111R	CUBIERTA TRASERA 140/60X13" COPERTONE TYRE	REIFEN PNEU	1 2	
03A		00G04702091	VALVULA AIRE VALVOLA ARIA VALVE, TYRE	LUFTVENTIL RAEDER SOUPAPE D'ADMISSION D'AIR	1 2	
04A		00H01304931	JUEGO PASTILLAS FRENO TRASERO CONG. PASTIGLIE FRENO SET OF BRAKE PADS	DIE GESAMTHEIT BREMSBACKEN ENS. PLAQUETTE DE FREIN	1 2	
05A		848039	DISTANCIAL RUEDA TRASERA GHIERA BUSH	DISTANZHULSE ENTRETOISE	1 2	
06A		597528	CASQUILLO SEP. TUERCA TRAS. GHIERA BUSH	DISTANZHULSE ENTRETOISE	1 2	
07A		00232160021	TUERCA 16M125 DADO NUT	MUTTER ECROU	1 2	
08A		00G02400111	CAPUCHON TUERCA RUEDA TRASERA DADO NUT	MUTTER ECROU	1 2	
09A		00702009321	PASADOR ABIERTO D4X32 SPINA PIN	STIFT GOUPILLE	1 2	
10A		598715	BUJE RUEDA TRASERA MOZZO HUB	NABE MOYEU	1 2	
11A		825758	TORNILLO 8M125X40 VITE SCREW	SCHRAUBE VIS	1 2	

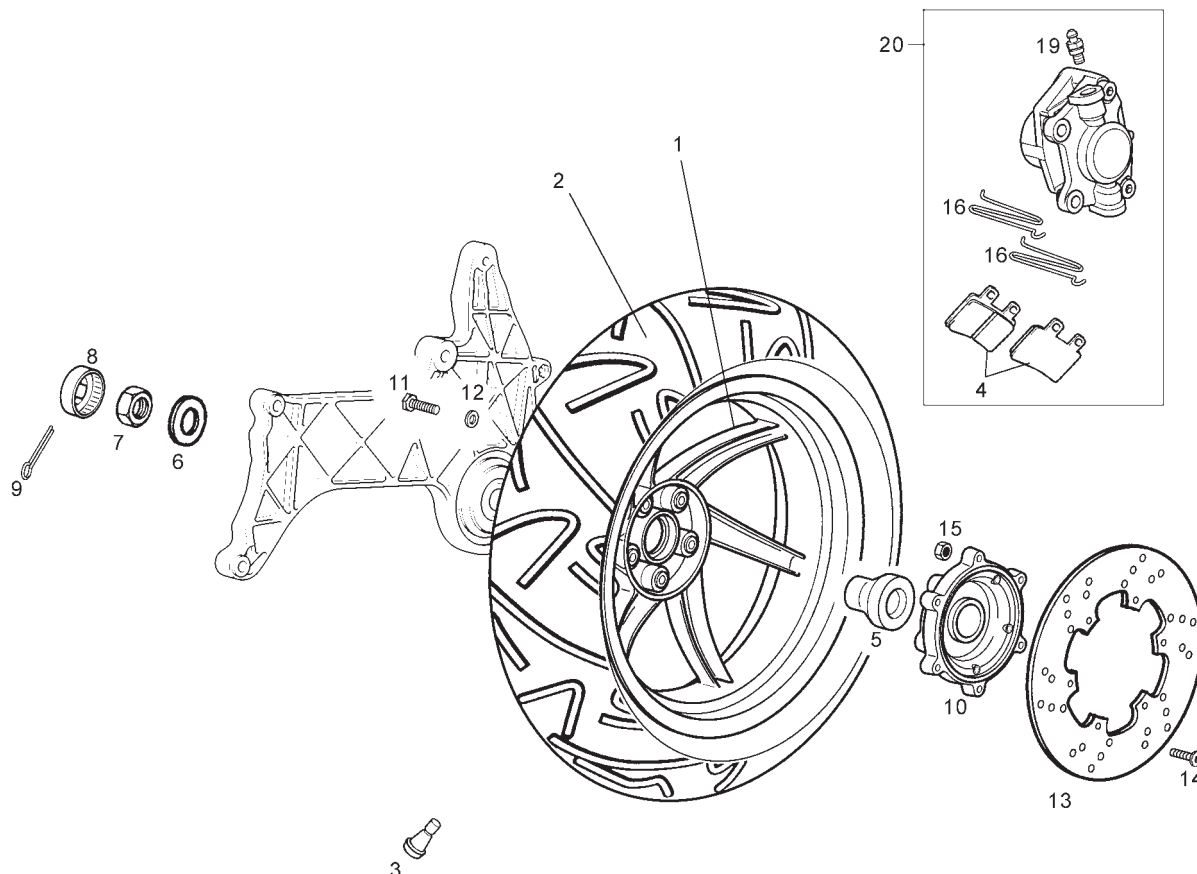

Fig.	Ver.	COD. KOD.	DESCRIPCIÓN DENOMINAZIONE NAME	BEZEICHNUNG DESIGNATION	MOD.	NOTAS NOTES NOTA MITSCHRIFT NOTES
12A		0000033080	ARANDELA MUELLE D8 RONDELLA WASHER	SCHEIBE RONDELLE	1 2	
13A		56391R	DISCO DE FRENO DISCO FRENO POSTERIORE REAR BRAKE DISC	BREMSSCHEIBE TR. DISQUE FREIN ARRIERE	1 2	
14A		00008063001	TORNILLO C/REDONDA ALLEN 6M100X30 VITE SCREW	SCHRAUBE VIS	1 2	
15A		00026006001	TUERCA EXAGONAL C/BRIDA 6M100 DADO NUT	MUTTER ECROU	1 2	
16A		00H01301831	MUELLE FIJACION PASTILLAS MOLLA SPRING	FEDER RESSORT	1 2	
17A		00002083001	TORNILLO 8M125X30 VITE SCREW	SCHRAUBE VIS	1 2	
18A		00402080001	ARANDELA D.8 RONDELLA WASHER	SCHEIBE RONDELLE	1 2	
19A		00H04702121	RACORD HIDRAULICO C/SANGRADOR SPURGO BLEED	ENTLUFTUNGSVENTIL EPURATEUR	1 2	
20A		864582	CTO PINZA FRENO TRASERO GANASCI A POSTERIORE REAR CLIP ASSEMBLY	BREMSZANGE HINTEN ETRIER FREIN ARR.	1 2	

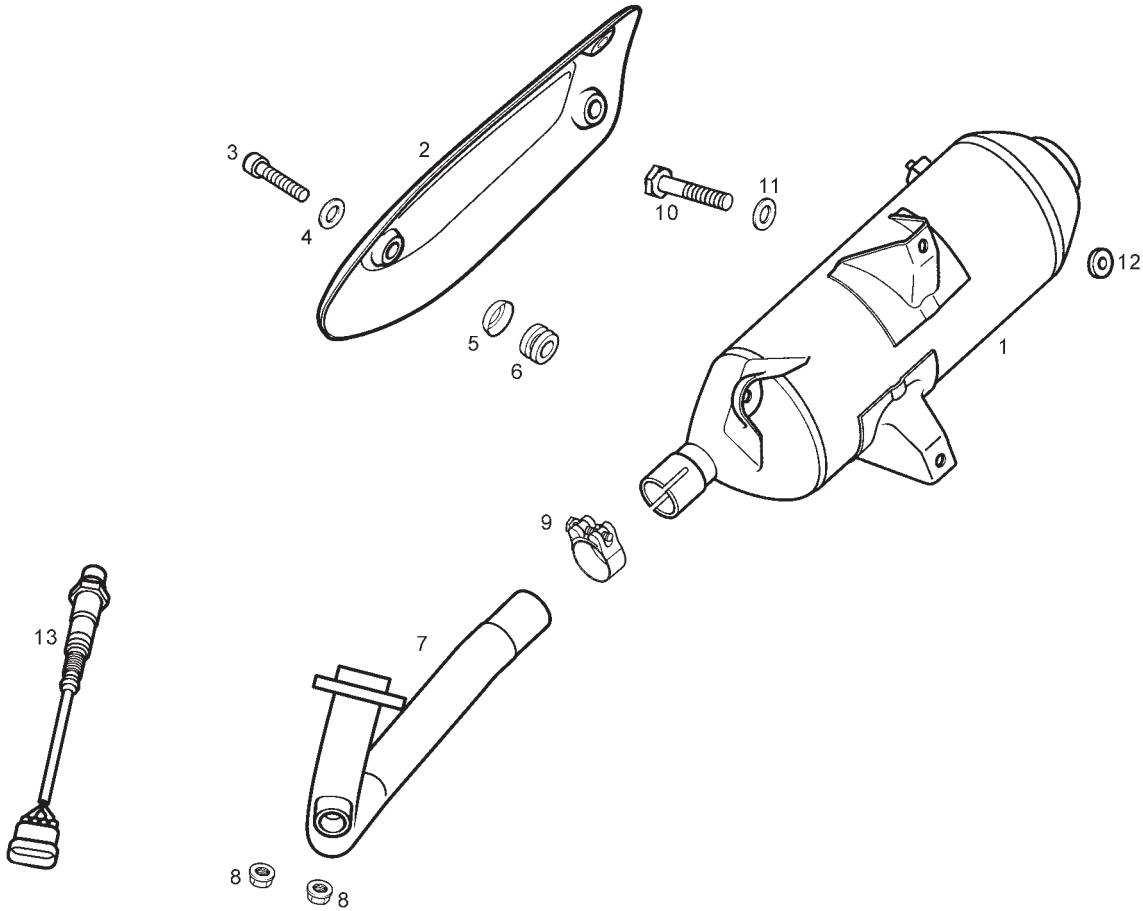

Fig.	Ver.	COD. KOD.	DESCRIPCIÓN DENOMINAZIONE NAME	BEZEICHNUNG DESIGNATION	MOD.	NOTAS NOTES NOTA MITSCHRIFT NOTES
01A		872871	SCTO.SORDINA SORDINA EXHAUST TANK	SCHALLDAMPFER SILENCIEUX D'ECHAPPEMENT	1 2	
02A		842404	PROTECTOR SORDINA SUPPORTO SORDINA EXHAUST TANK BRACKET	SCHALLDAMPFERSTUTZ SUPPORT SILENCIEUX D'ECHAPPEMENT	1 2	
03A		844641	TORNILLO ESCAPE VITE SCREW	SCHRAUBE VIS	1 2	
04A		827526	ARANDELA AISLANTE RONDELLA WASHER	SCHEIBE RONDELLE	1 2	
05A		482282	CAZOLETA FIJ. PROTECTOR ESCAPE SCADELLINO FISSAGGIO HOUSING	ABDECKSCHEIBE CUVETTE	1 2	
06A		487665	SILENTBLOCK PROTECTOR ESCAPE PROTEZIONE CAVI RUBBER,CABLE PROTECTOR	GUMMI PASSE-CABLE	1 2	
07A		863428	SCTO. TUBO ESCAPE TUBO SCAPPAMENTO EXHAUST PIPE	AUSPUFFTOPF POT ECHAPPEMENT	1 2	
08A		436947	TUERCA EXAGONAL C/BRIDA 7M100 DADO NUT	MUTTER ECROU	1 2	
09A		845320	ABRAZADERA FIJ. ESCAPE-SORDINA FASCETTA CLAMP	SHELLE COLLIER	1 2	
10A		00002083001	TORNILLO 8M125X30 VITE SCREW	SCHRAUBE VIS	1 2	
11A		00402080001	ARANDELA D8 RONDELLA WASHER	SCHEIBE RONDELLE	1 2	

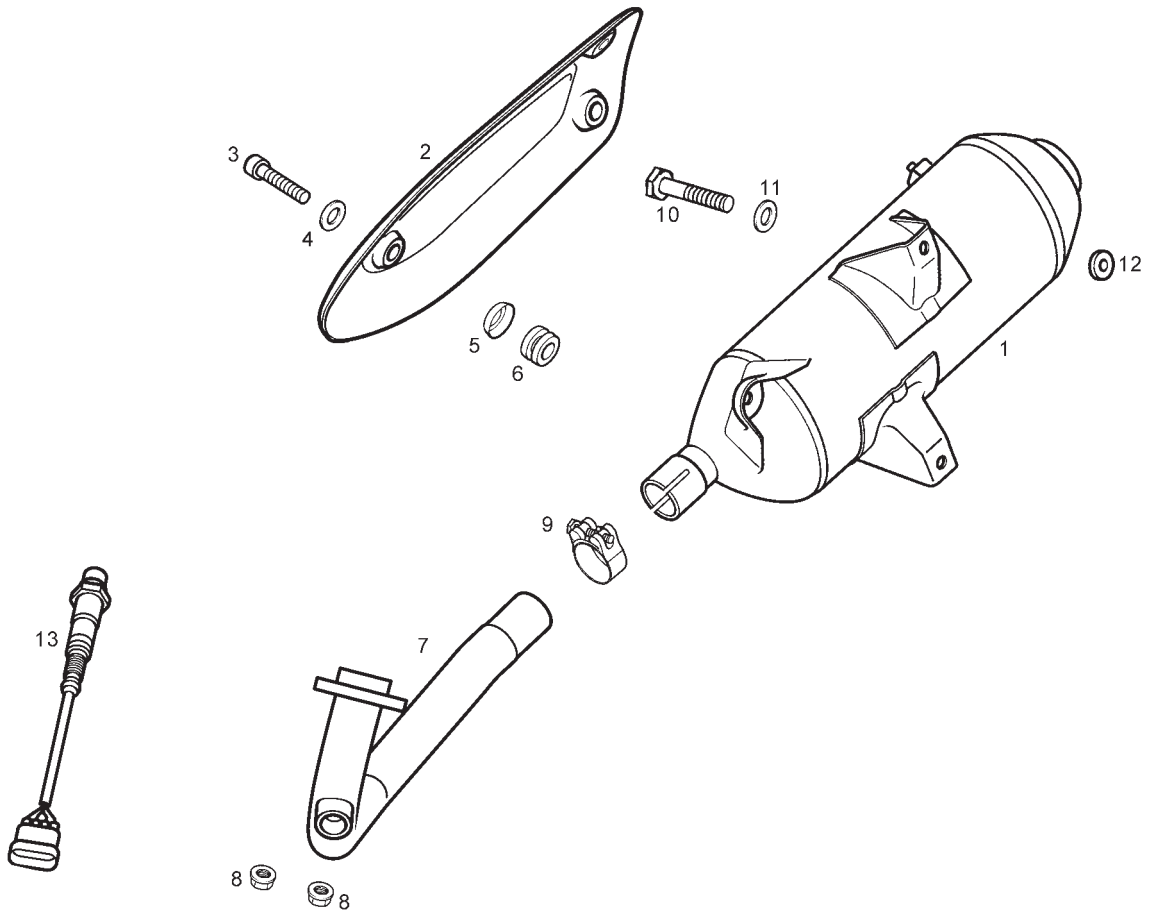

Fig.	Ver.	COD. KOD.	DESCRIPCIÓN DENOMINAZIONE NAME	BEZEICHNUNG DESIGNATION	MOD.	NOTAS NOTES NOTA MITSCHRIFT NOTES
12A		863693	CASQUILLO SEPARADOR SORDINA GHIERA BUSH	DISTANZHULSE ENTRETOISE	1 2	
13A		584344	SONDA LAMBDA ESCAPE SONDA PROBE	SONDE SONDE	1 2	

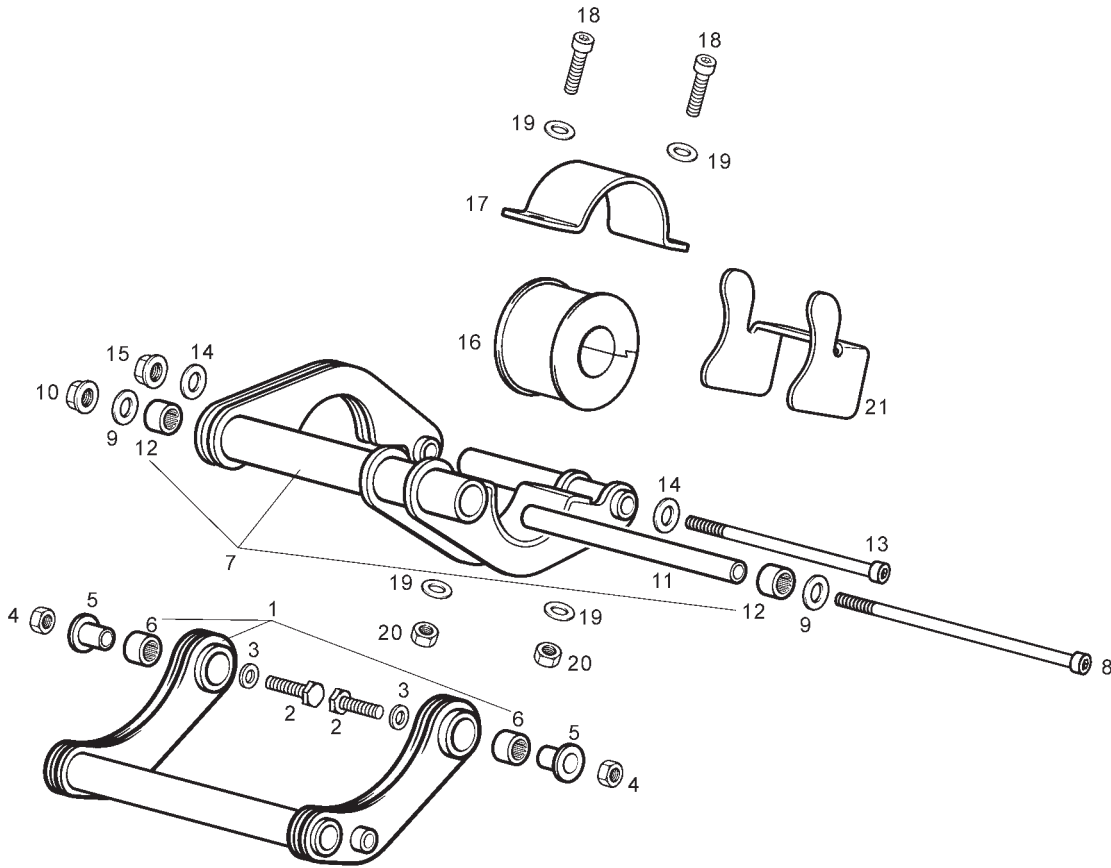

Fig.	Ver.	COD. KOD.	DESCRIPCIÓN DENOMINAZIONE NAME	BEZEICHNUNG DESIGNATION	MOD.	NOTAS NOTES NOTA MITSCHRIFT NOTES
01A		863379	CTO.SOPORTE ANTERIOR MOTOR SUPPORTO BRACKET	HALTERUNG SUPPORT	1 2	
02A		00022147071	TORNILLO EXAGONAL 14MX200X70 VITE SCREW	SCHRAUBE VIS	1 2	
03A		00032015000	ARANDELA PLANA D15 RONDELLA WASHER	SCHEIBE RONDELLE	1 2	
04A		00281141503	TUERCA EXAGONAL 14M200 DADO NUT	MUTTER ECROU	1 2	
05A		00G00102381	CASQUILLO SEP. SOPORTE MOTOR GHIERA BUSH	DISTANZHULSE ENTRETOISE	1 2	
06A		00G00300701	CASQUILLO AGUJAS GHIERA BUSH	DISTANZHULSE ENTRETOISE	1 2	
07A		861134	CTO.SOPORTE POSTERIOR MOTOR SUPPORTO BRACKET	HALTERUNG SUPPORT	1 2	
08A		00G03001271	TORNILLO FIJACION MOTOR VITE SCREW	SCHRAUBE VIS	1 2	
09A		00402100001	ARANDELA D10 RONDELLA WASHER	SCHEIBE RONDELLE	1 2	
10A		00000023100	TUERCA AUTOBLOCANTE 10M150 DADO NUT	MUTTER ECROU	1 2	
11A		00G00104831	TUBO SEPARADOR SOPORTE MOTOR TUBO TUBE	SCHLAUCH TUYAU	1 2	

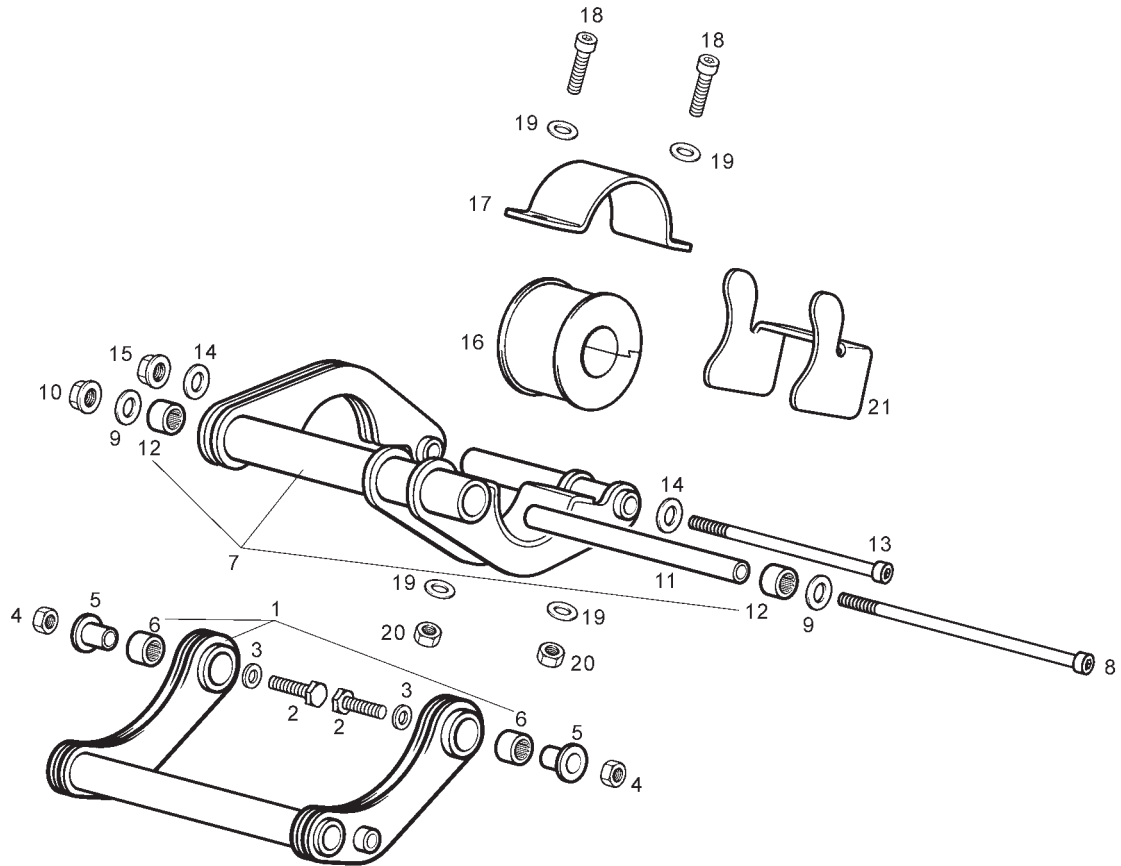

Fig.	Ver.	COD. KOD.	DESCRIPCIÓN DENOMINAZIONE NAME	BEZEICHNUNG DESIGNATION	MOD.	NOTAS NOTES NOTA MITSCHRIFT NOTES
12A		00G00300811	CASQUILLO AGUJAS GHIERA BUSH	DISTANZHULSE ENTRETOISE	1 2	
13A		00G03002271	TORNILLO FIJ. SOP. MOTOR A MOTOR VITE SCREW	SCHRAUBE VIS	1 2	
14A		00402100001	ARANDELA D10 RONDELLA WASHER	SCHEIBE RONDELLE	1 2	
15A		00000023100	TUERCA AUTOBLOCANTE 10M150 DADO NUT	MUTTER ECROU	1 2	
16A		00G00308401	SILENTBLOCK SOPORTE MOTOR SILENTBLOCK SILENTBLOCK	SILENTBLOCK SILENTBLOCK	1 2	
17A		00G01501431	BRIDA FIJACION SILENTBLOCK FLANGIA CLAMP	BINDER COLLIER	1 2	
18A		00002082021	TORNILLO 8M125X20 VITE SCREW	SCHRAUBE VIS	1 2	
19A		00402080001	ARANDELA D8 RONDELLA WASHER	SCHEIBE RONDELLE	1 2	
20A		00262080022	TUERCA 8M125 DADO NUT	MUTTER ECROU	1 2	
21A		861043	BRIDA RETENCION SILENTBLOCK FLANGIA CLAMP	BINDER COLLIER	1 2	

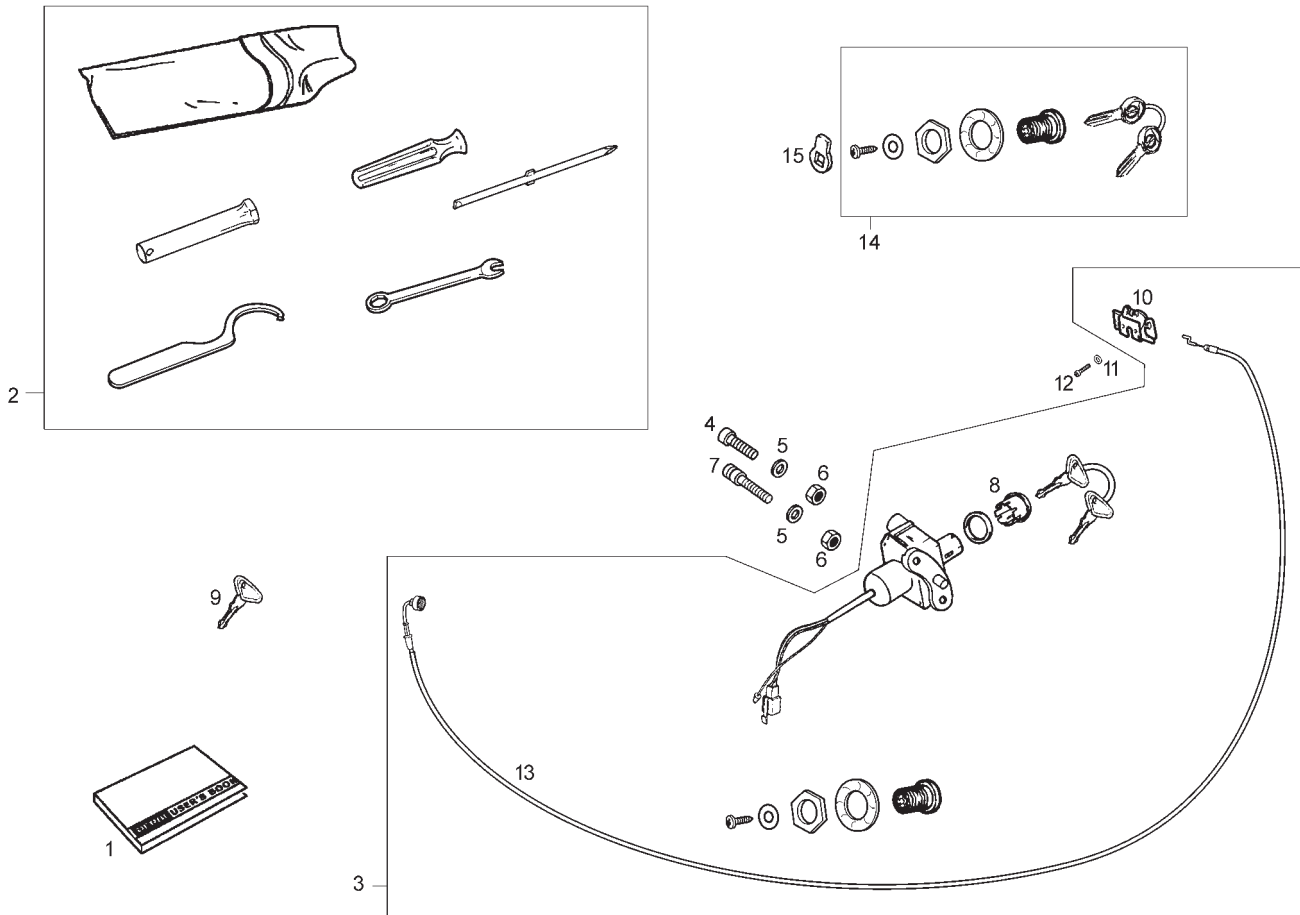

Fig.	Ver.	COD. KOD.	DESCRIPCIÓN DENOMINAZIONE NAME	BEZEICHNUNG DESIGNATION	MOD.	NOTAS NOTES NOTA MITSCHRIFT NOTES
01A		863944	MANUAL DE INSTRUCCIONES LIBRETTI DI ISTRUZIONI USER'S BOOK	BEDIENUNGSANLEITUNG MANUEL D'INSTRUCTIONS	1 2	
02A		00G05107561	CTO.BOLSA HERRMTAS.GP1 250CC SACCO FERRI TOOL BAG ASSY	WERKZEUGBEUTEL SAC A OUTILS COMPLET	1 2	
03A		00G05909251	KIT CERRADURAS SERRATURE LOCK WITH KEYS	SCHLOOS-SATZ ENS.KIT SERRURES	1 2	
04A		00002062011	TORNILLO 6M100X20 VITE SCREW	SCHRAUBE VIS	1 2	
05A		00402060001	ARANDELA D6 RONDELLA WASHER	SCHEIBE RONDELLE	1 2	
06A		00000023060	TUERCA AUTOBLOCANTE 6M100 DADO NUT	MUTTER ECROU	1 2	
07A		828152	TORNILLO ANTIMANIPULACION VITE SCREW	SCHRAUBE VIS	1 2	
08A		00G01500021	INDICADOR POSICION LLAVE INDICATORE INDICATOR	INDIKATOR INDICATEUR	1 2	
09A		00H01801411	LLAVE CERRADURA POR MECANIZAR LOCK KEYS CHIAVE	CLEF FERMETURE SELLE	1 2	
10A		00G06801501	PLACA CIERRE SILLIN CHIUSURA SELLA SADDLE LOCKER	VERSCHLUSS SITZ VIS	1 2	
11A		00012061200	TORNILLO 6M100X12 VITE SCREW	SCHRAUBE RONDELLE	1 2	

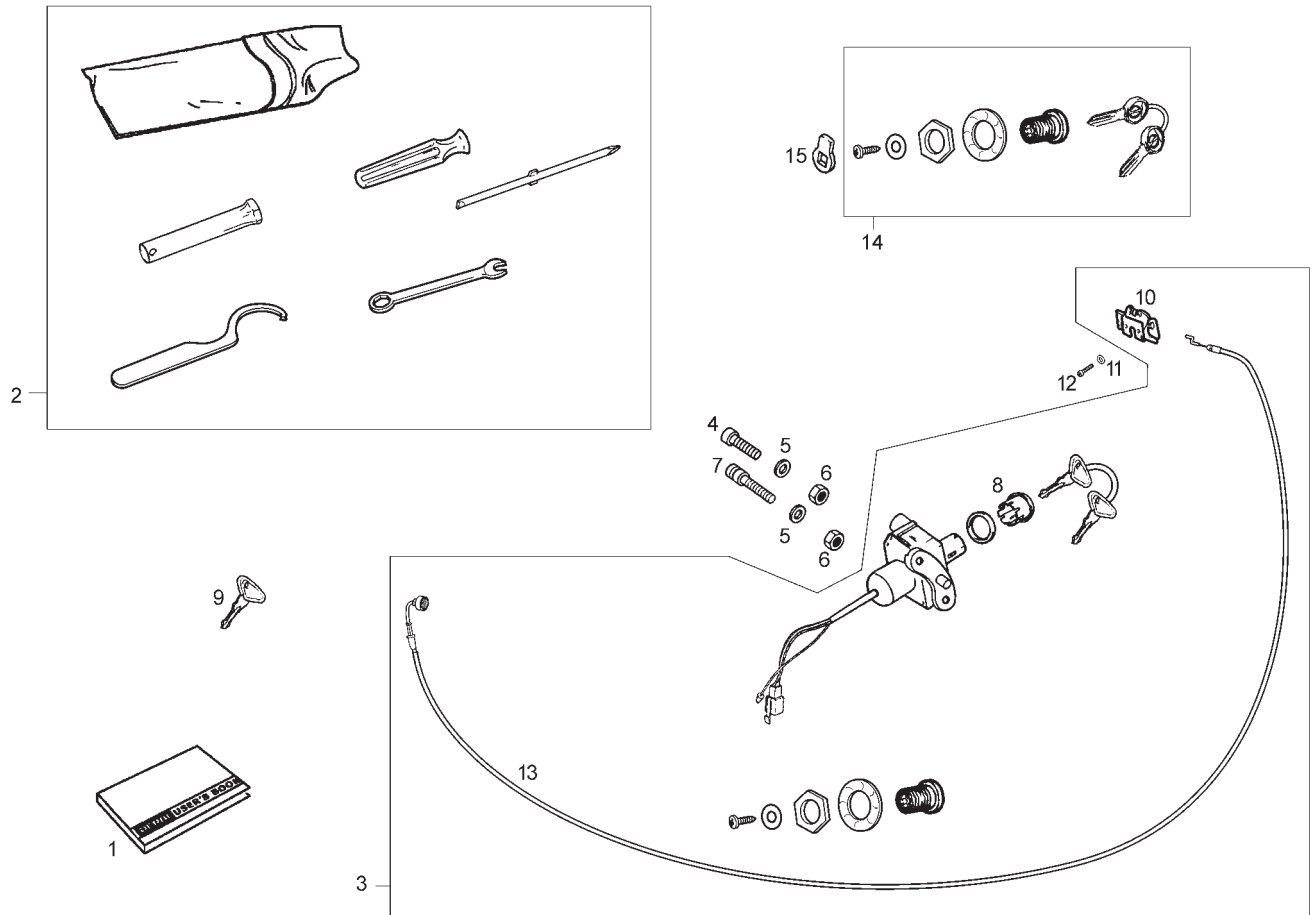

Fig.	Ver.	COD. KOD.	DESCRIPCIÓN DENOMINAZIONE NAME	BEZEICHNUNG DESIGNATION	MOD.	NOTAS NOTES NOTA MITSCHRIFT NOTES
12A		00031106000	ARANDELA PLANA D6 RONDELLA WASHER	SCHEIBE SOUS-EN.CABLE FERMETURE SELLE	1 2	
13A		00G00604181	SCTO CABLE CIERRE SILLIN CAVO CHIUSURA SELLA SADDLE LOCKING CABLE ASSY	VERSCHLUSSKABEL SITZ SCHLUSSEL	1 2	
14A		00H00600681	CTO CERRADURA SERRATURE LOCK WITH KEYS	SCHLOOS-SATZ ENS. KIT SERRURES	1 2	
15A		00G00601141	PALANCA CIERRE SILLIN LEVA LEVER	HEBEL LEVIER	1 2	

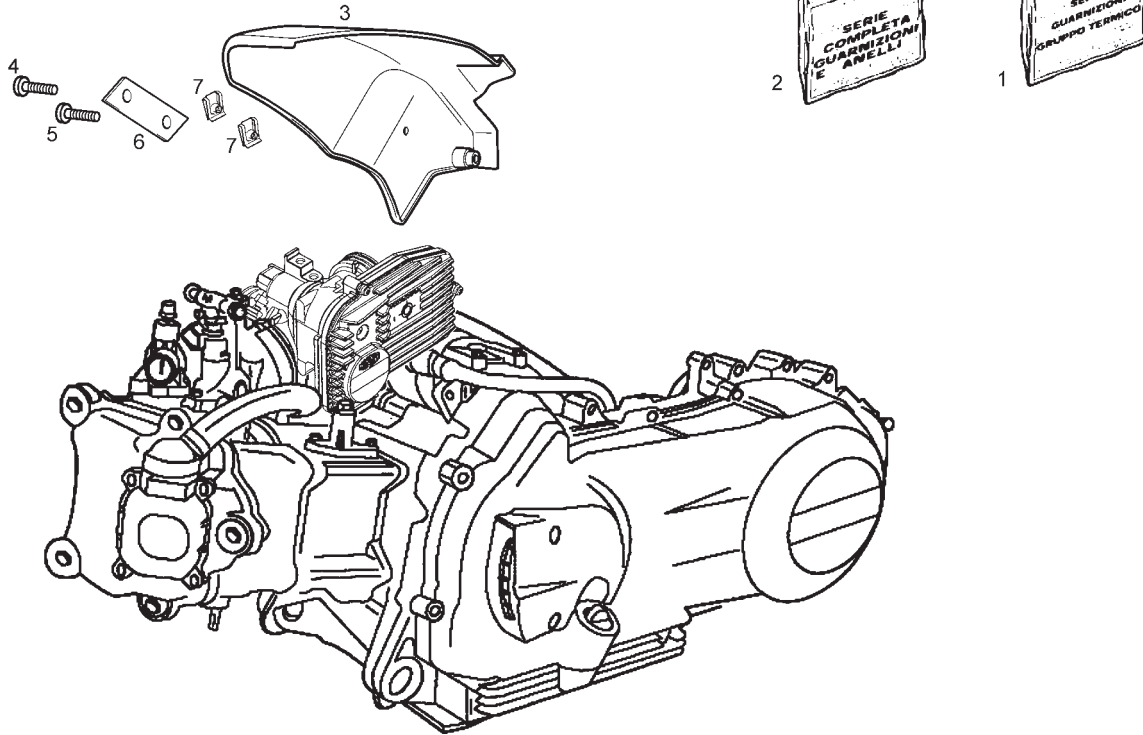

Fig.	Ver.	COD. KOD.	DESCRIPCIÓN DENOMINAZIONE NAME	BEZEICHNUNG DESIGNATION	MOD.	NOTAS NOTES NOTA MITSCHRIFT NOTES
01A		497070	JUEGO JUNTAS SERIE GUARNIZ. GRUPO TERMICO GASK. SET THERMIC UNIT	DICHTUNGSSATZ THERM. EINHEIT SET JOIN. GROUPE THERMIQUE	1 2	
02A		497069	JUEGO RETENES SER. GUARN. E PARAOLI OIL SEAL AND GASK. SET	DICHT. UND OLSCHUTZ JEU BAGUES D'ET.	1 2	
03A		00G01800121	TAPA CUBRE-BOBINA COPERCHIO COVER	DECKEL COUVERCLE	1 2	
04A		00008062000	TORNILLO C/RED ALLEN 6M100X20 VITE SCREW	SCHRAUBE VIS	1 2	
05A		00008061500	TORNILLO C/RED ALLEN 6M100X15 VITE SCREW	SCHRAUBE VIS	1 2	
06A		861132	SOPORTE SUPPORTO BRACKET	HALTERUNG SUPPORT	1 2	
07A		00D01501371	TUERCA FIJACION D6 DADO NUT	MUTTER ECROU	1 2	

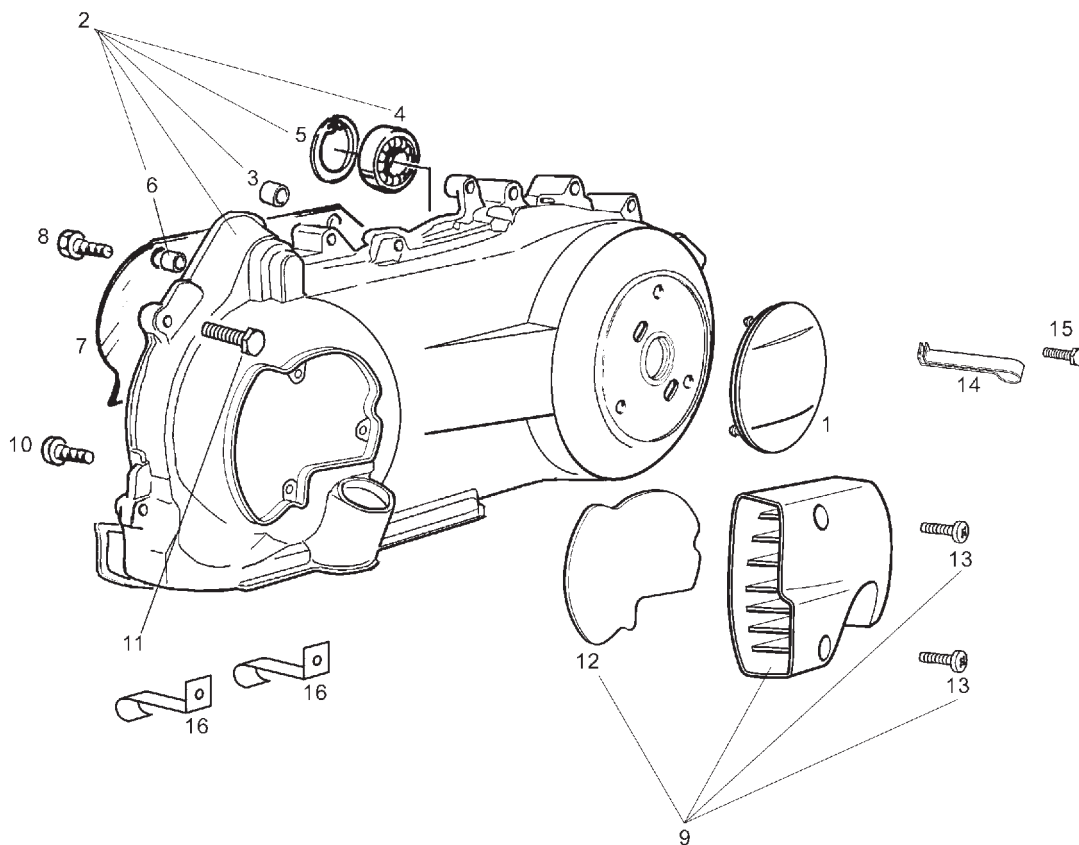

Fig.	Ver.	COD. KOD.	DESCRIPCIÓN DENOMINAZIONE NAME	BEZEICHNUNG DESIGNATION	MOD.	NOTAS NOTES NOTA MITSCHRIFT NOTES
01A		CM155102	TAPETA NEUTRA COPERCHIETTO COVER	DECKEL COUVERCLE	1 2	
02A		8714725	TAPA TRANSMISIONES COPERCHIO TRASMISSIONE COVER	DECKEL COUVERCLE	1 2	
03A		431860	CASQUILLO BUSSOLA (GRUPPO RINVIO BUSH	DISTANZHULSE ENTRETOISE	1 2	
04A		478985	COJINETE 15x35x11 CUSCINETTO BEARING	LAGER ROULEMENT	1 2	
05A		006635	ANILLO ELASTICO ANELLO O'RING	RING ANNEAU	1 2	
06A		239388	PASADOR SPINA RIFERIMENTO PIN	STIFT GOUPILLE	1 2	
07A		834266	DESVIADOR AIRE DEVIATORE ARIA WARM AIR DIAPHRAGM	WARMLUFTABWEICHUNG DIAPHRAGME POUR AIR CHAUD	1 2	
08A		430264	TORNILLO AUTORROSCANTE VITE SCREW	SCHRAUBE VIS	1 2	
09A		842090	TAPA REFRIGERACION COPERCHIO RAFFREDDAMENTO COVER	DECKEL COUVERCLE	1 2	
10A		270793	TORNILLO AUTORROSCANTE 3x16 VITE SCREW	SCHRAUBE VIS	1 2	
11A		289731	TORNILLO M6x30 VITE SCREW	SCHRAUBE VIS	1 2	

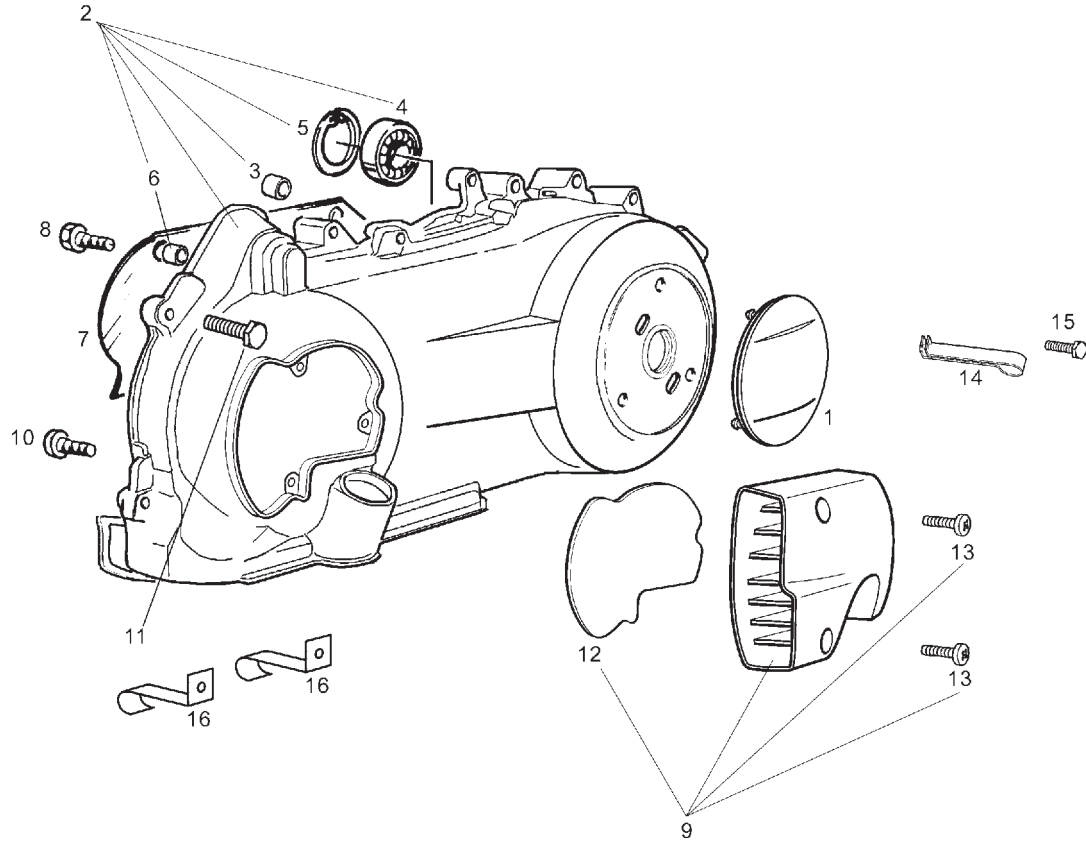

Fig.	Ver.	COD. KOD.	DESCRIPCIÓN DENOMINAZIONE NAME	BEZEICHNUNG DESIGNATION	MOD.	NOTAS NOTES NOTA MITSCHRIFT NOTES
12A		842093	FILTRO DE AIRE SOFFIETTO PRESA ARIA COPER. BELLOWS	BALG MANCHON	1 2	
13A		258146	TORNILLO AUTOROSCANTE 3X20 VITE SCREW	SCHRAUBE VIS	1 2	
14A		597418	BRIDA FIJACION CABLES FLANGIA CLAMP	BINDER COLLIER	1 2	
15A		00G03900821	TORNILLO FIJACION 6X30 VITE SCREW	SCHRAUBE VIS	1 2	
16A		844964	ABRAZADERA FASCETTA CLAMP	SHELLE COLLIER	1 2	

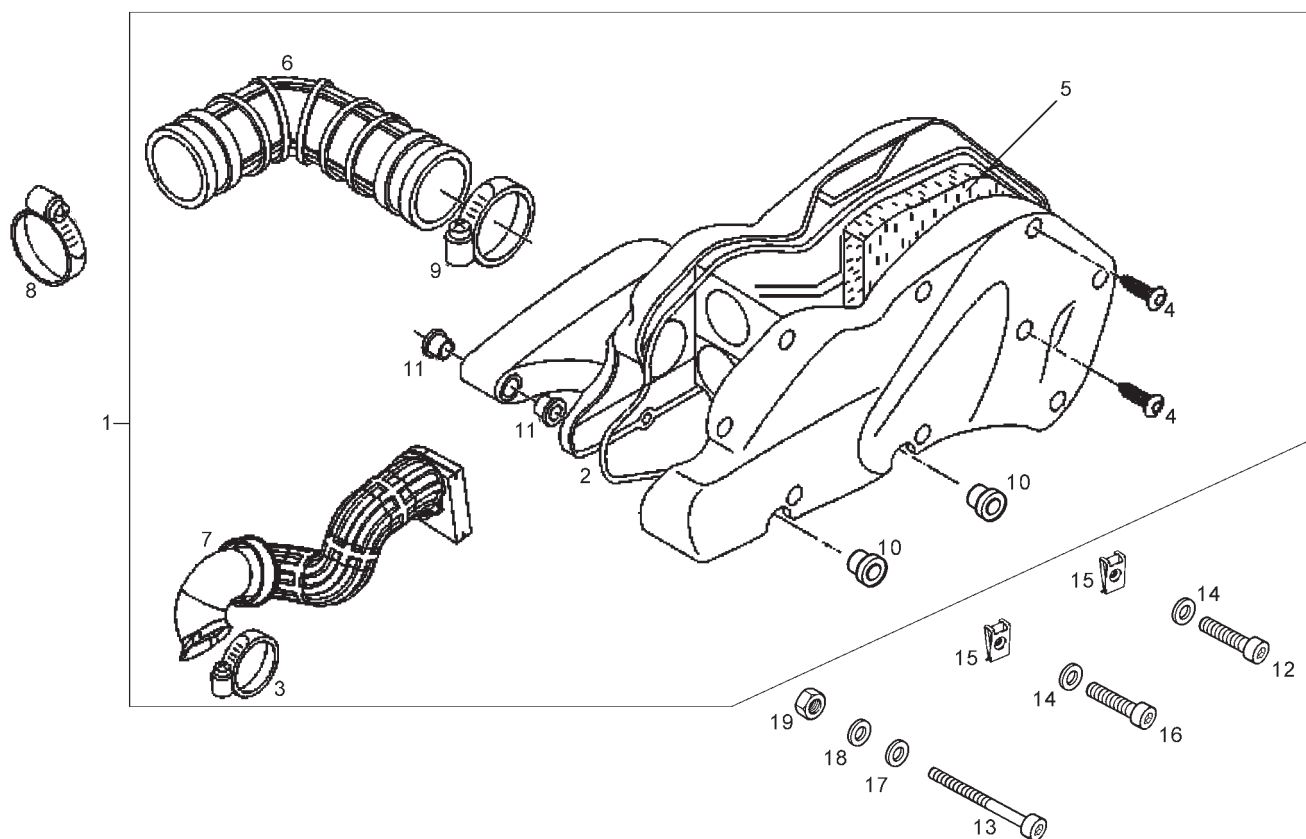

Fig.	Ver.	COD. KOD.	DESCRIPCIÓN DENOMINAZIONE NAME	BEZEICHNUNG DESIGNATION	MOD.	NOTAS NOTES NOTA MITSCHRIFT NOTES
01A		871805	CTO CAJA FILTRO DEPURATORE ARIA COMPL. AIR.CL.CASE	LUFTFILTERGEHÄUSE BOÎTE FILTRE	1 2	
02A		829259	JUNTA GUARNIZIONE PACKING	DICHTUNG JOINT	1 2	
03A		830015	ABRAZADERA FASCETTA CLAMP	SHELLE COLLIER	1 2	
04A		258146	TORNILLO VITE SCREW	SCHRAUBE VIS	1 2	
05A		829258	FILTRO DE AIRE FILTRO ARIA AIR FILTER	LUFTFILTER FILTRE À AIR	1 2	
06A		829543	MANGUITO CAJA FILTRO-CARBU. MANICOTTO DEPURATORE-CARBURA. SLEEVE	MUFFE MANCHON	1 2	
07A		848864	MANGUITO ASPIRACION MANICOTTO DEPURATORE/VEICOLO SLEEVE	MUFFE MANCHON	1 2	
08A	00H03200271		ABRAZADERA FUELLE ADMISIÓN D50-70 FASCETTA CLAMP	SHELLE COLLIER	1 2	
09A	CM002910		ABRAZADERA FASCETTA CLAMP	SHELLE COLLIER	1 2	
10A		830056	CASQUILLO GHIERA BUSH	DISTANZHULSE ENTRETOISE	1 2	
11A		830057	CASQUILLO GHIERA BUSH	DISTANZHULSE ENTRETOISE	1 2	

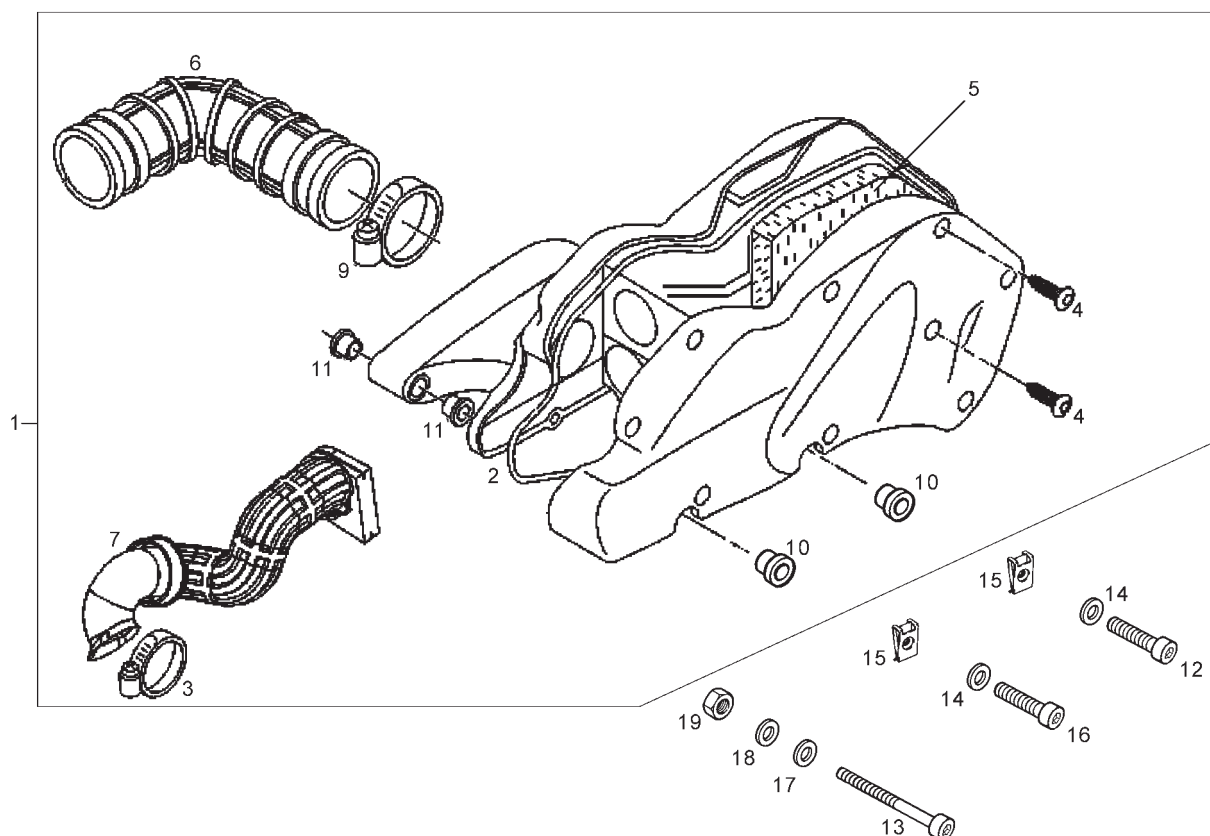

Fig.	Ver.	COD. KOD.	DESCRIPCIÓN DENOMINAZIONE NAME	BEZEICHNUNG DESIGNATION	MOD.	NOTAS NOTES NOTA MITSCHRIFT NOTES
12A		00002064011	TORNILLO 6M100X40 VITE SCREW	SCHRAUBE VIS	1 2	
13A		00000004660	TORNILLO C/ALLEN 6M100X60 VITE SCREW	SCHRAUBE VIS	1 2	
14A		00D01200171	ARANDELA D6 RONDELLA WASHER	SCHEIBE RONDELLE	1 2	
15A		00D01501371	TUERCA FIJACION D6 DADO NUT	MUTTER ECROU	1 2	
16A		00000004650	TORNILLO C/ALLEN 6M100X50 VITE SCREW	SCHRAUBE VIS	1 2	
17A		00D01200171	ARANDELA RONDELLA WASHER	SCHEIBE RONDELLE	1 2	
18A		00402060001	ARANDELA D6 RONDELLA WASHER	SCHEIBE RONDELLE	1 2	
19A		00000023060	TUERCA AUTOBLOCANTE 6M100 DADO NUT	MUTTER ECROU	1 2	

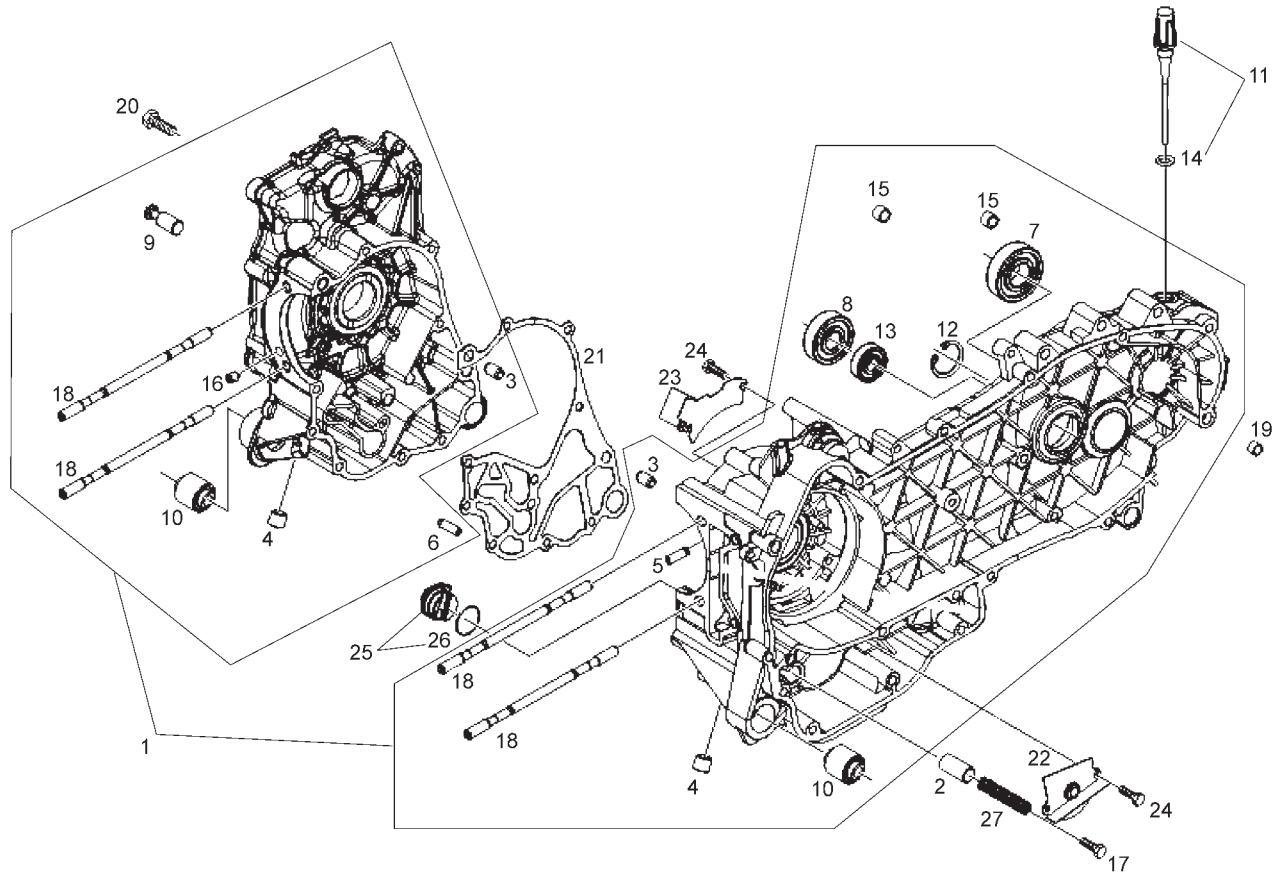

Fig.	Ver.	COD. KOD.	DESCRIPCIÓN DENOMINAZIONE NAME	BEZEICHNUNG DESIGNATION	MOD.	NOTAS NOTES NOTA MITSCHRIFT NOTES
01A		8462415001	CTO CARTERS 1ª CAT CARTER COMPLETE CRANKCASE	KURBELWELLENGEHÄUSE CARTER	1 2	
01B		8462415002	CTO CARTERS 2ª CAT CARTER COMPLETE CRANKCASE	KURBELWELLENGEHÄUSE CARTER	1 2	
02A		829661	VALVULA BY-PASS ACEITE VALVOLA REGOLAZIONE VALVE	VENTIL SOUPAPE	1 2	
03A		239388	PASADOR SPINA RIFERIMENTO PIN	STIFT GOUPILLE	1 2	
04A		411311	TAPÓN TAPPO FILETTATO CONICO CAP	KAPPE BOUCHON	1 2	
05A		484034	BOQUILLA UGELLO CALIBRATO NOZZLE	DUSE GICLEUR	1 2	
06A		239388	PASADOR SPINA RIFERIMENTO PIN	STIFT GOUPILLE	1 2	
07A		485912	COJINETE RADIAL 15.42.13 CUSCINETTO BEARING	LAGER ROULEMENT	1 2	
08A		833701	COJINETE CUSCINETTO BEARING	LAGER ROULEMENT	1 2	
09A		483785	PERNO PERNO PIN	ZAPFEN PIVOT	1 2	
10A		486081	SILENTBLOCK PERNO PIN	ZAPFEN PIVOT	1 2	

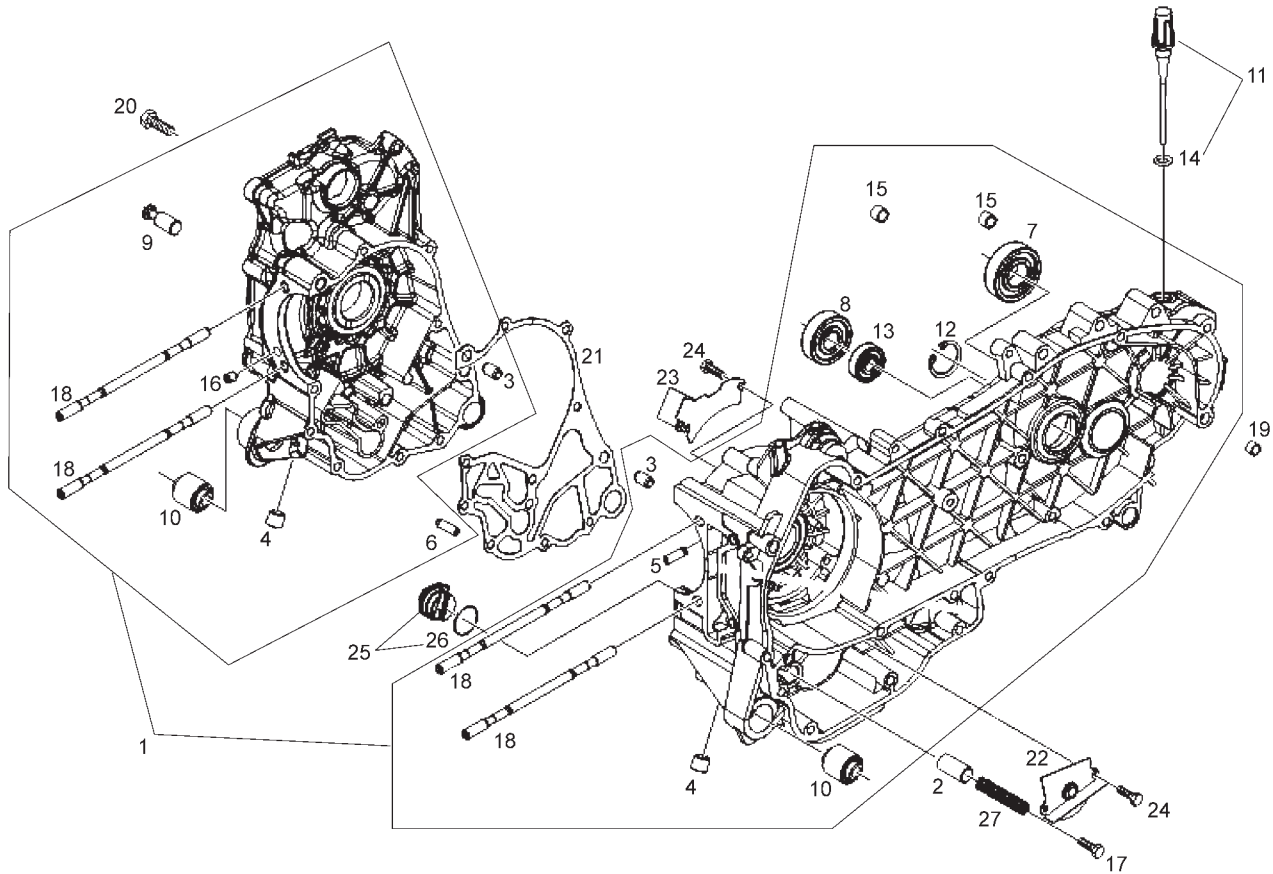

Fig.	Ver.	COD. KOD.	DESCRIPCIÓN DENOMINAZIONE NAME	BEZEICHNUNG DESIGNATION	MOD.	NOTAS NOTES NOTA MITSCHRIFT NOTES
11A		832130	VARILLA NIVEL ACEITE ASTA LIVELLO OLIO ROD	STANGE TIGE	1 2	
12A		000674	ANILLO ANELLO ELASTICO O'RING	RING ANNEAU	1 2	
13A		82878R	RETEN 20-32-7 ANELLO DI TENUTA SEAL	DICHTRING JOINT	1 2	
14A		827085	JUNTA TORICA ANELLO DI TENUTA PACKING	DICHTUNG JOINT	1 2	
15A		478115	CENTRAJE GRANO DI RIFERIMENTO DOWEL	STIFT GOUJON	1 2	
16A		844582	BOQUILLA UGELLO CALIBRATO NOZZLE	DUSE GICLEUR	1 2	
17A		018575	TORNILLO VITE SCREW	SCHRAUBE VIS	1 2	
18A		840332	ESPARRAGO M8x165 PRIGIONIERO STUD	STIFTSCHRAUBE GOUJON	1 2	
19A		277916	CENTRAJE 7,5x12 GRANO DI RIFERIMENTO DOWEL	STIFT GOUJON	1 2	
20A		432142	TORNILLO M6X60 VITE SCREW	SCHRAUBE VIS	1 2	
21A		845212	JUNTA CARTER GUARNIZIONE SEMICARTER PACKING	DICHTUNG JOINT	1 2	

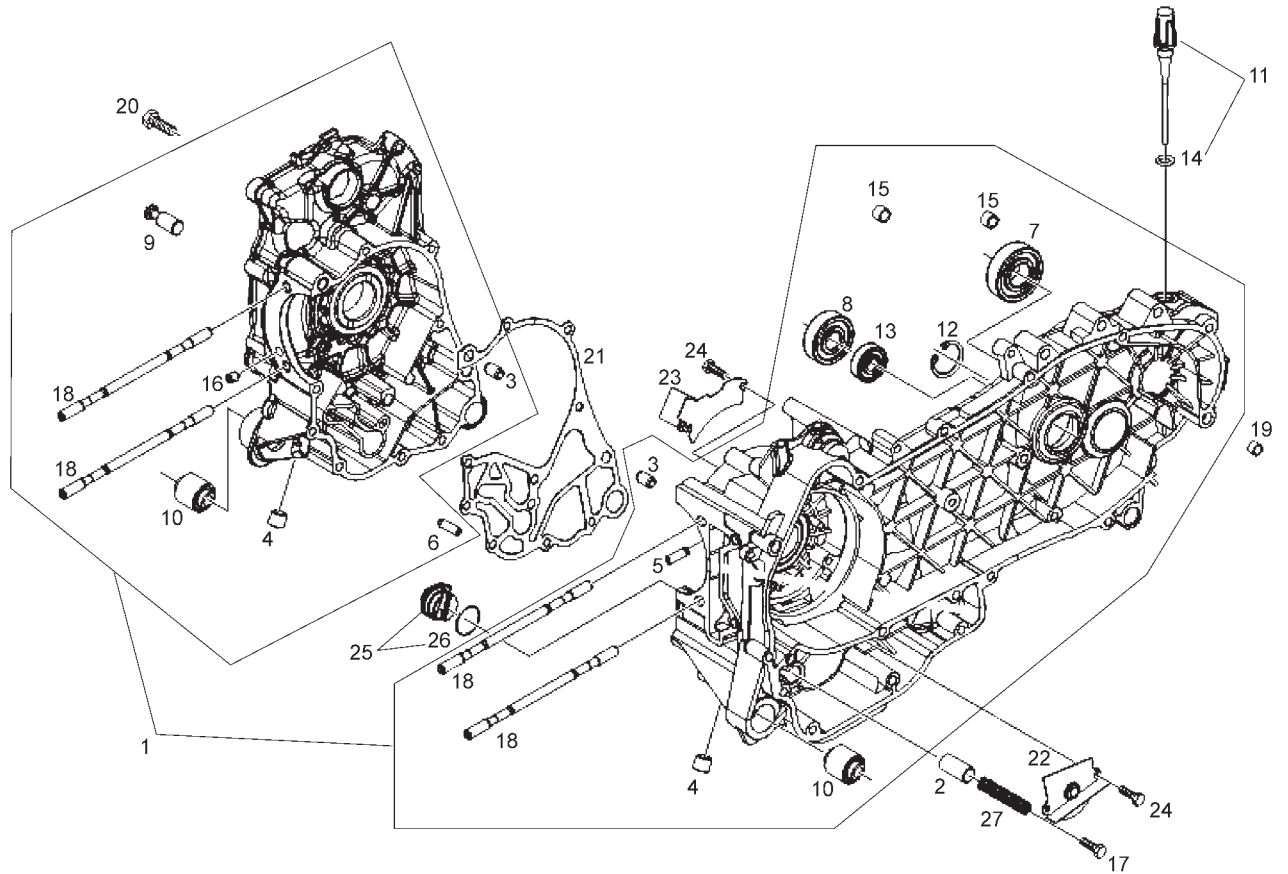

Fig.	Ver.	COD. KOD.	DESCRIPCIÓN DENOMINAZIONE NAME	BEZEICHNUNG DESIGNATION	MOD.	NOTAS NOTES NOTA MITSCHRIFT NOTES
22A		483767	MAMPARA ACEITE PARATIA OLIO PLATE	PLÄTTCHEN PLAQUETTE	1 2	
23A		485047	MAMPARA ACEITE SUPERIOR PARATIA OLIO SUPERIORE PLATE	PLÄTTCHEN PLAQUETTE	1 2	
24A		830061	TORNILLO EXAGONAL VITE SCREW	SCHRAUBE VIS	1 2	
25A		845861	SOPORTE FILTRO MALLA ACEITE INSERTO PORTA FILTRO BRACKET	HALTERUNG SUPPORT	1 2	
26A		431065	JUNTA TORICA GUARNIZIONE PACKING	DICHTUNG JOINT	1 2	
27A		485655	MUELLE VALVULA PRESION ACEITE MOLLA VALVOLA PRESSION SPRING	FEDER RESSORT	1 2	

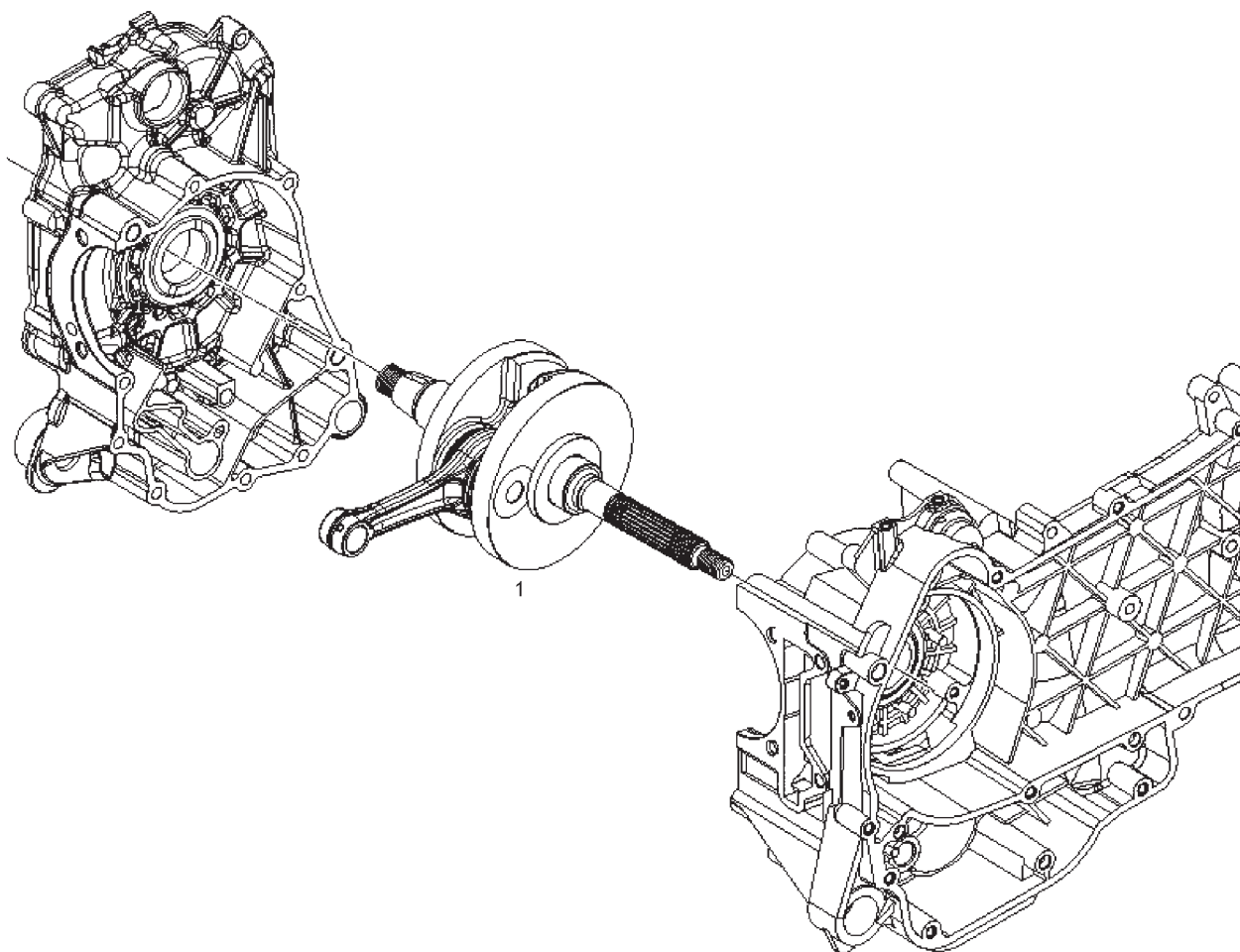

Fig.	Ver.	COD. KOD.	DESCRIPCIÓN DENOMINAZIONE NAME	BEZEICHNUNG DESIGNATION	MOD.	NOTAS NOTES NOTA MITSCHRIFT NOTES
01A		8423835001	CTO CIGÜENAL-BIELA 1ª CAT ALBERO MOTORE COMPLETO CRANKSHAFT	KURBELWELLE VILEBREQUIN	1 2	
01B		8423835002	CTO CIGÜENAL-BIELA 2ª CAT ALBERO MOTORE COMPLETO CRANKSHAFT	KURBELWELLE VILEBREQUIN	1 2	

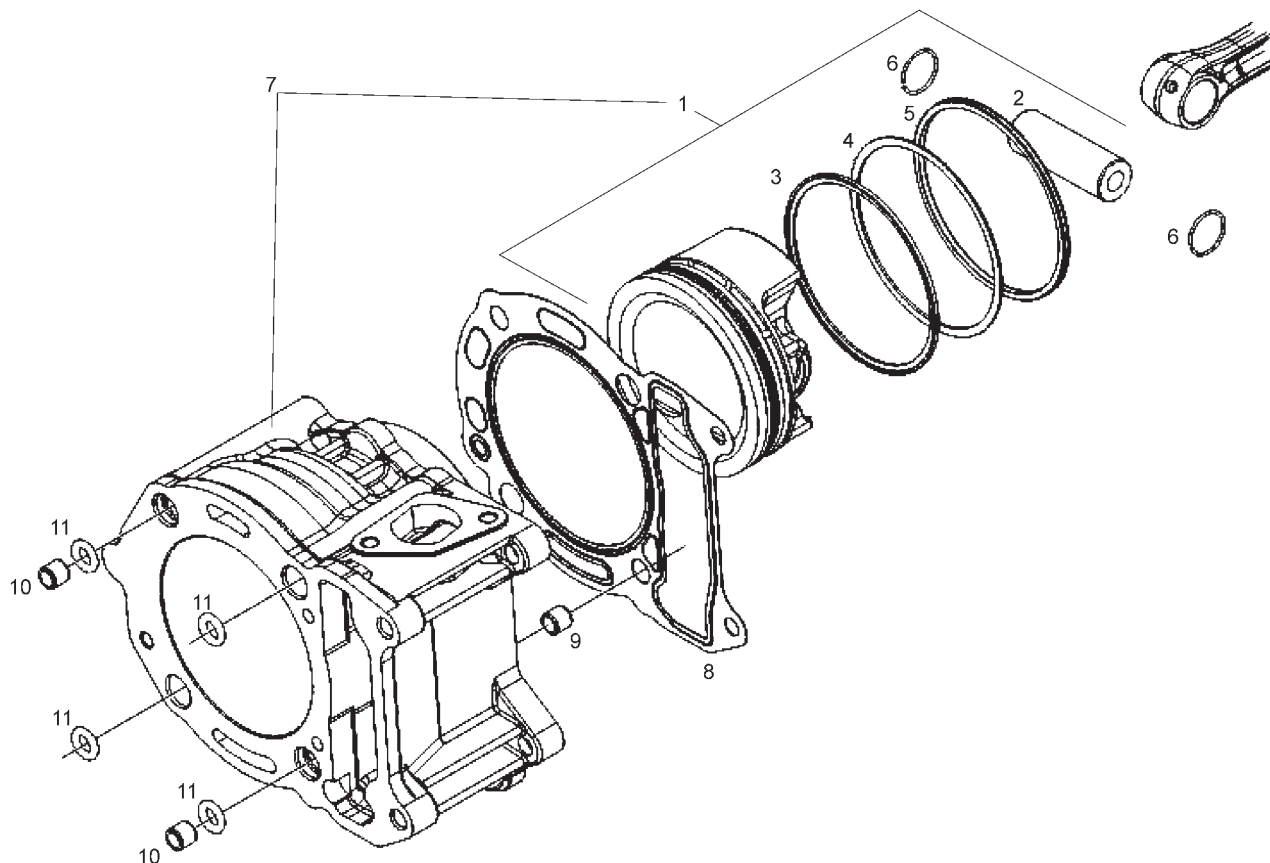

Fig.	Ver.	COD. KOD.	DESCRIPCIÓN DENOMINAZIONE NAME	BEZEICHNUNG DESIGNATION	MOD.	NOTAS NOTES NOTA MITSCHRIFT NOTES
01A		8435190001	CTO PISTON 1ª CAT PISTONE COMPLETO PISTON ASSY.	KOLBEN KPL. ENS PISTON	1 2	
01B		8435190002	CTO PISTON 2ª CAT PISTONE COMPLETO PISTON ASSY.	KOLBEN KPL. ENS PISTON	1 2	
01C		8435190003	CTO PISTON 3ª CAT PISTONE COMPLETO PISTON ASSY.	KOLBEN KPL. ENS PISTON	1 2	
01D		8435190004	CTO PISTON 4ª CAT PISTONE COMPLETO PISTON ASSY.	KOLBEN KPL. ENS PISTON	1 2	
02A		829529	BULON SPINOTTO PIN	ZAPPEN AXE	1 2	
03A		843228	ARO PISTON SEGMENTO COMPRESIONE PACKING	DICHTUNG JOINT	1 2	
04A		486363	ARO PISTON SEGMENTO RASCHIOLIO PACKING	DICHTUNG JOINT	1 2	
05A		484908	ARO PISTON SEGMENTO RASCHIOLIO PACKING	DICHTUNG JOINT	1 2	
06A		963486	ANILLO BULON PISTON ANELLO RITEGNO SPINOTTO O'RING	RING ANNEAU	1 2	
07A		843517	CTO CILINDRO-PISTON CILINDRO-PISTONE COMPLETO CYLINDER UNIT	ZYLINDER GR. CYLINDRE	1 2	
08A		828146	JUNTA CILINDRO 0,4 MM GUARNIZIONE CILINDRO/CARTER PACKING	DICHTUNG JOINT	1 2	

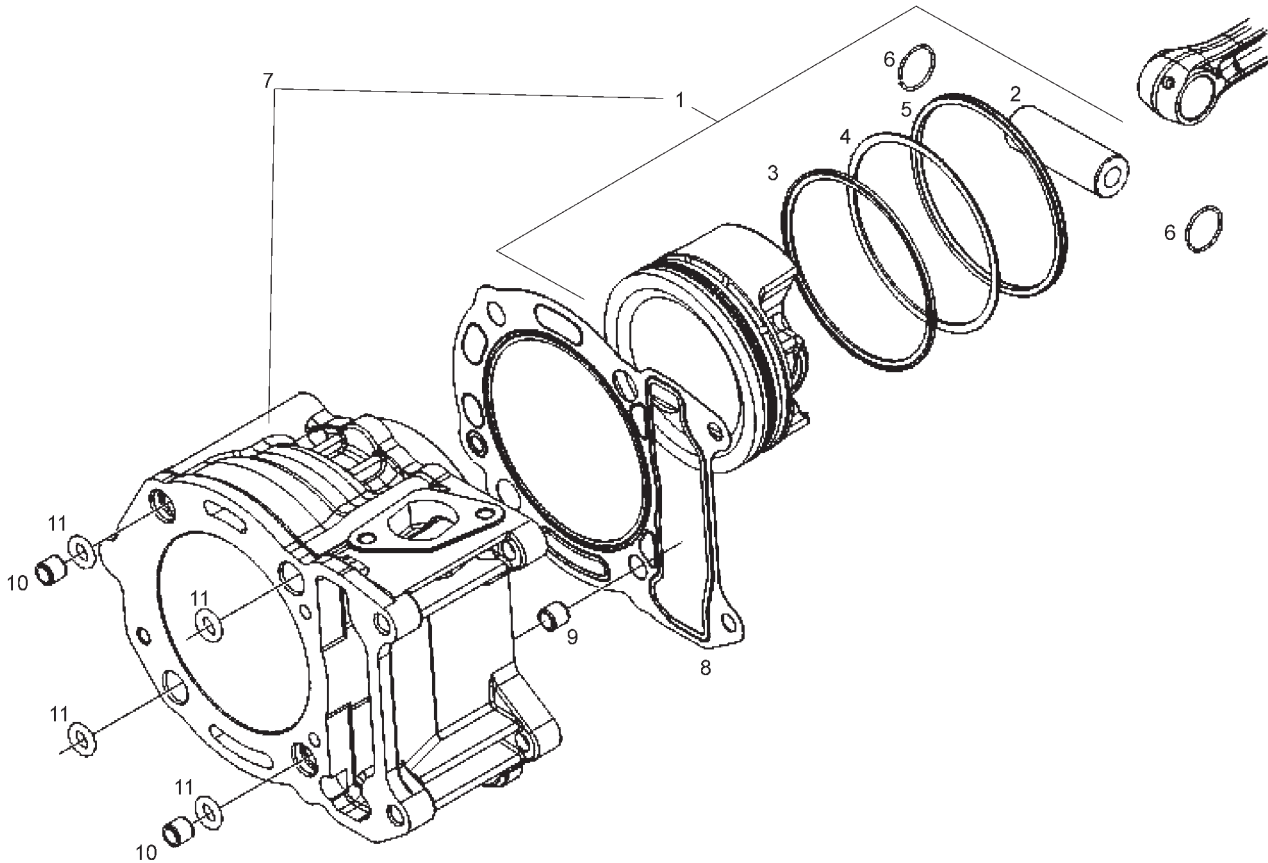

Fig.	Ver.	COD. KOD.	DESCRIPCIÓN DENOMINAZIONE NAME	BEZEICHNUNG DESIGNATION	MOD.	NOTAS NOTES NOTA MITSCHRIFT NOTES
08B		828147	JUNTA CILINDRO 0,6 MM GUARNIZIONE CILINDRO/CARTER PACKING	DICHTUNG JOINT	1 2	
08C		828148	JUNTA CILINDRO 0,8 MM GUARNIZIONE CILINDRO/CARTER PACKING	DICHTUNG JOINT	1 2	
09A		277916	CENTRAJE 7,5x12 GRANO DI RIFERIMENTO DOWEL	STIFT GOIJON	1 2	
10A		478115	CENTRAJE GRANO DI RIFERIMENTO DOWEL	STIFT GOIJON	1 2	
11A		478184	JUNTA TORICA ESPARRAGO ANELLO O-RING PACKING	DICHTUNG JOINT	1 2	



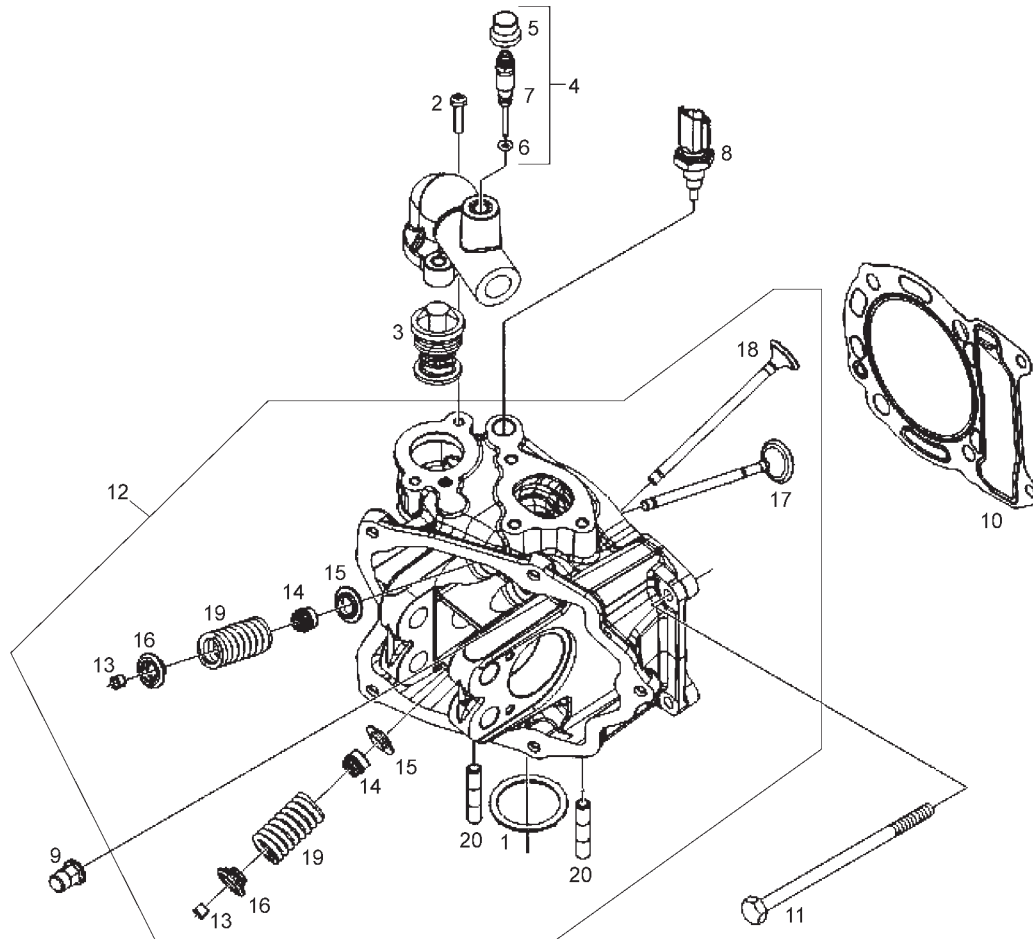

Fig.	Ver.	COD. KOD.	DESCRIPCIÓN DENOMINAZIONE NAME	BEZEICHNUNG DESIGNATION	MOD.	NOTAS NOTES NOTA MITSCHRIFT NOTES
12A		872849	CTO CULATA TESTA CILINDRO COMPLETA CYLINDER HEAD	KOPF CULASSE	1 2	
13A		285846	SEMICASQUILLO SEMICONI HALF BUSH	DISTANZHULSE ENTRETOISE	1 2	
14A		436438	RETEN DE VALVULA ANELLO DI TENUTA SEAL	DICHTRING JOINT	1 2	
15A		483711	ARANDELA INF. MUELLE VALVULA SCODELLINO INFERIORE WASHER	SCHEIBE RONDELLE	1 2	
16A		483914	CAZOLETA SUPERIOR SCODELLINO SUPERIORE WASHER	SCHEIBE RONDELLE	1 2	
17A		873009	VALVULA ESCAPE VALVOLA DI SCARICO VALVE	VENTIL SOUPAPE	1 2	
18A		872999	VALVULA ADMISION VALVOLA DI ASPIRAZIONE VALVE	VENTIL SOUPAPE	1 2	
19A		828480	MUELLE VALVULA MOLLA VALVOLA SPRING	FEDER RESSORT	1 2	
20A		435629	ESPARRAGO M7X37 PRIGIONIERO SPECIALE STUD	STIFTSCHRAUBE GOUJON	1 2	

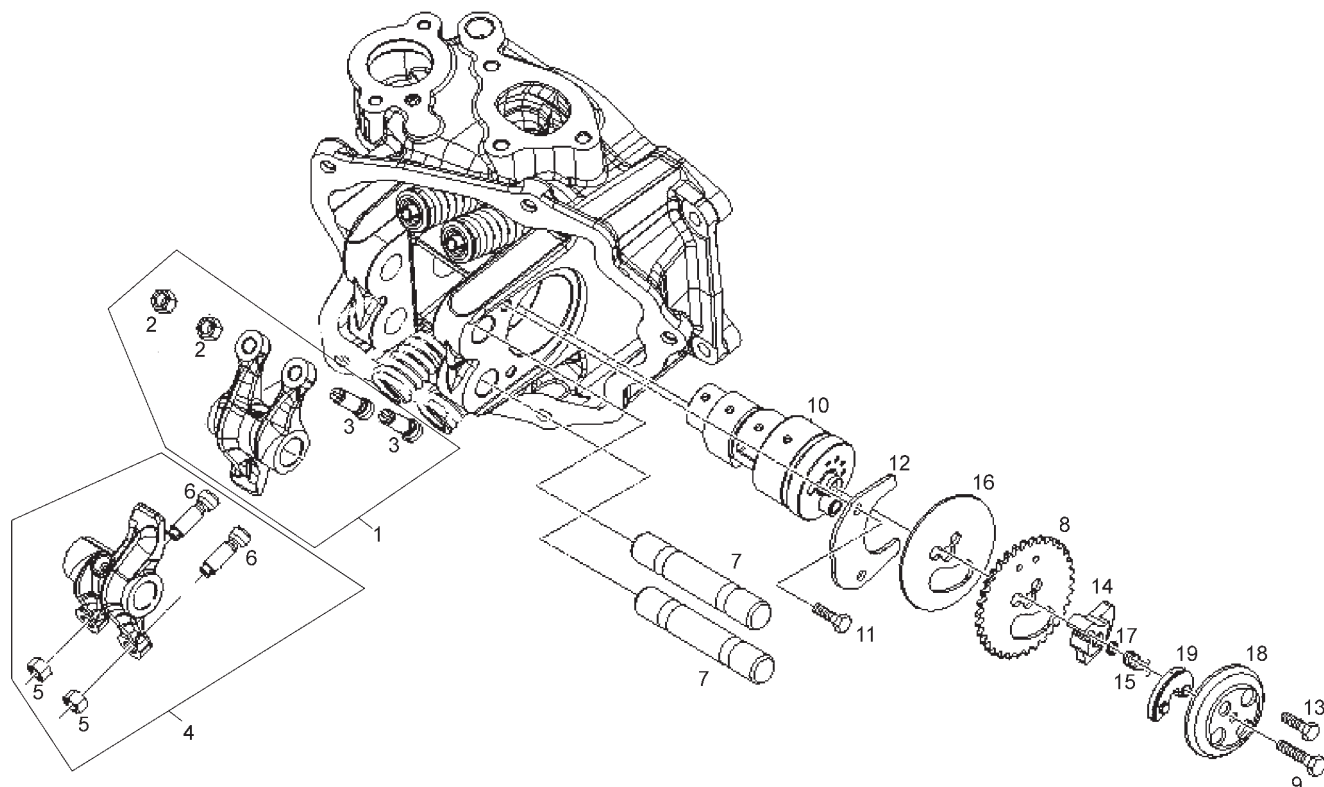

Fig.	Ver.	COD. KOD.	DESCRIPCIÓN DENOMINAZIONE NAME	BEZEICHNUNG DESIGNATION	MOD.	NOTAS NOTES NOTA MITSCHRIFT NOTES
01A		4847395	BALANCIN LADO ADMISION BILANCIERE LADO ASPIRAZIONE LEVER	KIPPHEBEL BALANCIER	1 2	
02A		484819	TUERCA REGULACION BALANCIN DADO NUT	MUTTER ECROU	1 2	
03A		82817R	TORNILLO BALANCIN VITE SCREW	SCHRAUBE VIS	1 2	
04A		4847405	BALANCIN LADO ESCAPE BILANCIERE LADO SCARICO LEVER	KIPPHEBEL BALANCIER	1 2	
05A		484819	TUERCA REGULACION BALANCIN DADO NUT	MUTTER ECROU	1 2	
06A		82817R	TORNILLO BALANCIN VITE SCREW	SCHRAUBE VIS	1 2	
07A		486343	EJE DE BALANCINES ASSE BILANCIERI SHAFT	ACHSE ESSIEU	1 2	
08A		486336	CORONA DISTRIBUCION CORONA DISTRIBUZIONE GEAR	GETRIEBE ENGRENAGE	1 2	
09A		414838	TORNILLO M6X35 VITE SCREW	SCHRAUBE VIS	1 2	
10A		847791	ARBOL DE LEVAS ASSE A CAMME SHAFT	ACHSE ESSIEU	1 2	
11A		484123	TORNILLO M5x12 VITE SCREW	SCHRAUBE VIS	1 2	

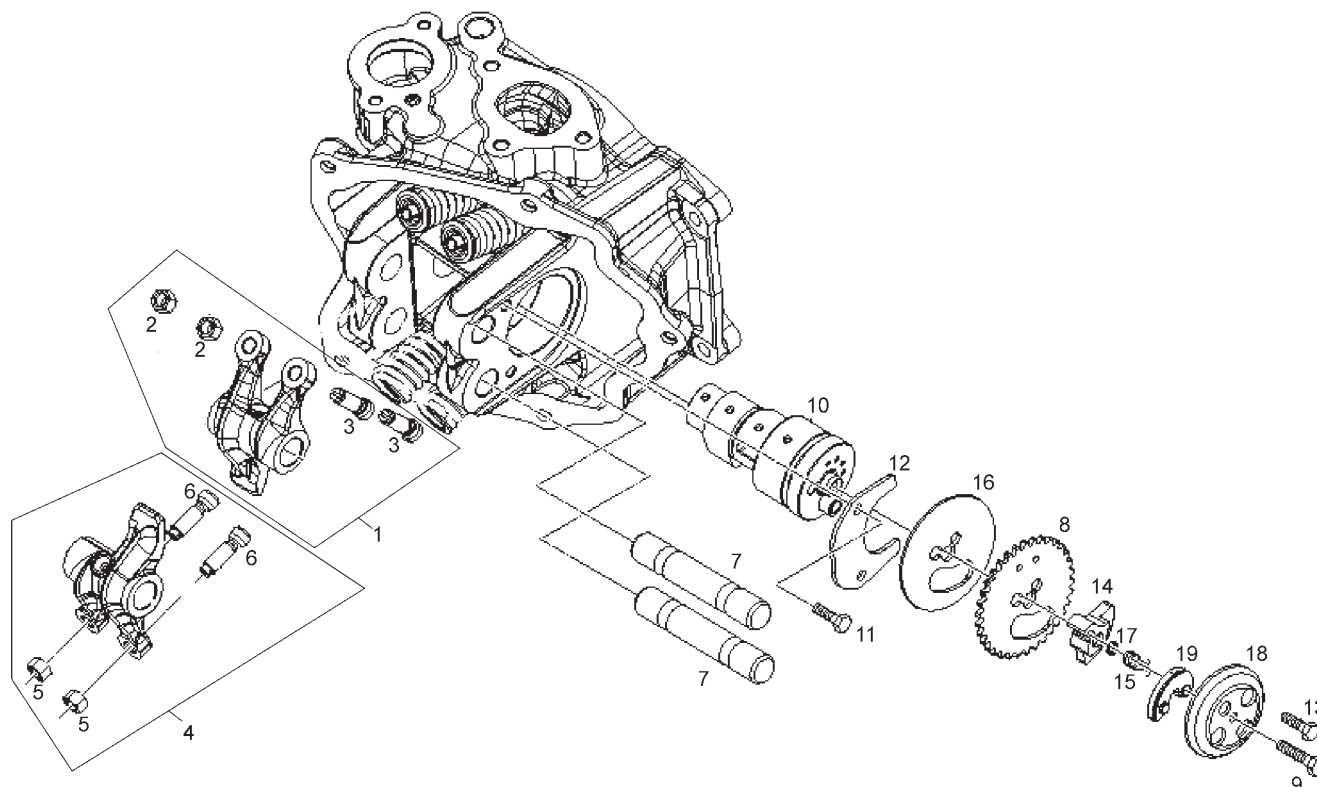

Fig.	Ver.	COD. KOD.	DESCRIPCIÓN DENOMINAZIONE NAME	BEZEICHNUNG DESIGNATION	MOD.	NOTAS NOTES NOTA MITSCHRIFT NOTES
12A		833308	PRECINTO ARBOL DE LEVAS LAMIERINO ALBERO A CAMME SHEET	BLECHSTÜCK TÖLE	1 2	
13A		018538	TORNILLO M5X30 VITE SCREW	SCHRAUBE VIS	1 2	
14A		486331	CONTRAPESO DESCOMPRESOR CONTRAPPESO DECOMPRESS COUNTERWEIGHT	GEGENGEWICHT CONTRE POIDS	1 2	
15A		486974	MUELLE DESCOMPRESOR MOLLA DECOMPRESSORE SPRING	FEDER RESSORT	1 2	
16A		487832	ARANDELA ESPECIAL RONDELLA WASHER	SCHEIBE RONDELLE	1 2	
17A		487833	JUNTA GUARNIZIONE PACKING	DICHTUNG JOINT	1 2	
18A		826396	TAPA DESCOMPRESOR CAMPANA DECOMPRESSORE COVER	DECKEL COUVERCLE	1 2	
19A		829139	MASA DESCOMPRESOR MASSETTA DECOMPRESSORE MASS	MASSE MASSE	1 2	

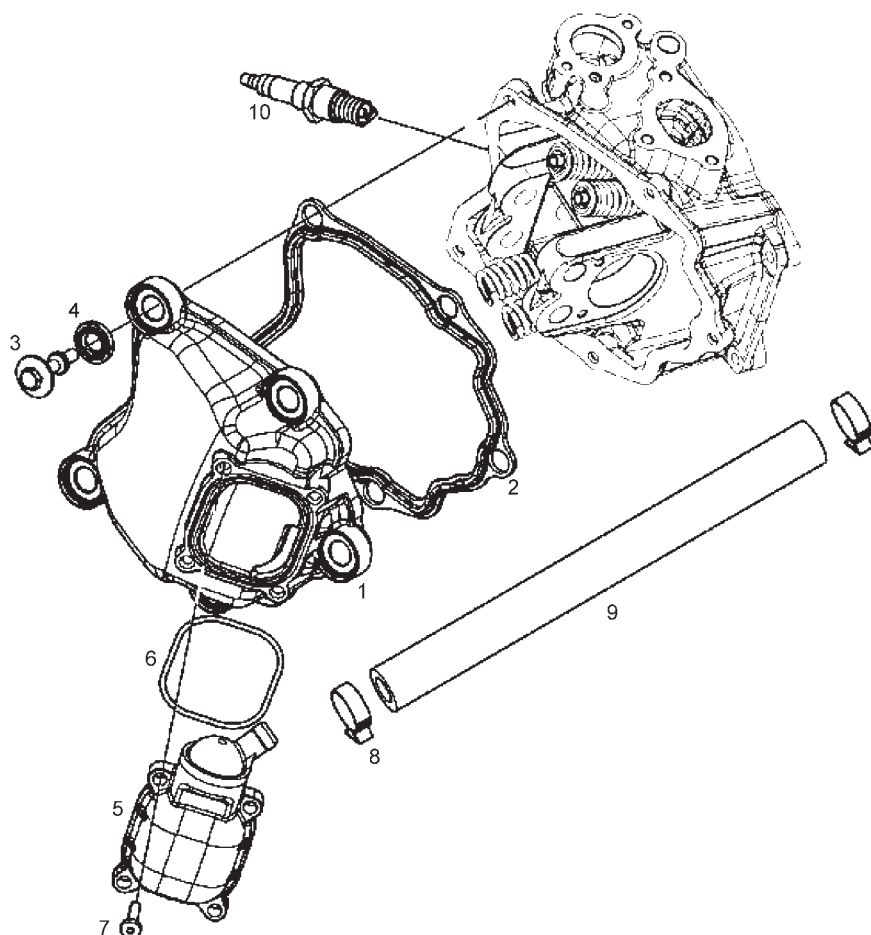

Fig.	Ver.	COD. KOD.	DESCRIPCIÓN DENOMINAZIONE NAME	BEZEICHNUNG DESIGNATION	MOD.	NOTAS NOTES NOTA MITSCHRIFT NOTES
01A		829534	TAPA BALANCINES COPERCHIO TESTA COVER	DECKEL COUVERCLE	1 2	
02A		829536	JUNTA TAPA BALANCINES GUARNIZIONE COPERCHIO PACKING	DICHTUNG JOINT	1 2	
03A		830248	TORNILLO ESPECIAL TAPA VITE SCREW	SCHRAUBE VIS	1 2	
04A		830249	SILENTBLOCK TAMPONE SMORZATORE SILENTBLOCK	SILENTBLOCK SILENTBLOCK	1 2	
05A		828421	RESPIRADERO CORPO SFIATO OLIO BREATHER	ENTLÜFTER RENIFLARD	1 2	
06A		487989	JUNTA TORICA GUARNIZIONE (O-RING) PACKING	DICHTUNG JOINT	1 2	
07A		828653	TORNILLO VITE SCREW	SCHRAUBE VIS	1 2	
08A		CM001904	ABRAZADERA FASCETTA STRINGITUBO CLAMP	SHELLE COLLIER	1 2	
09A		844094	TUBO RESPIRADERO ACEITE TUBETTO SFIATO OLIO TUBE	ROHR TUYAU	1 2	
10A		639205	BUJIA CANDELA DI ACCENSIONE SPARK PLUG	ZUNDKERZE BOUGIE	1 2	

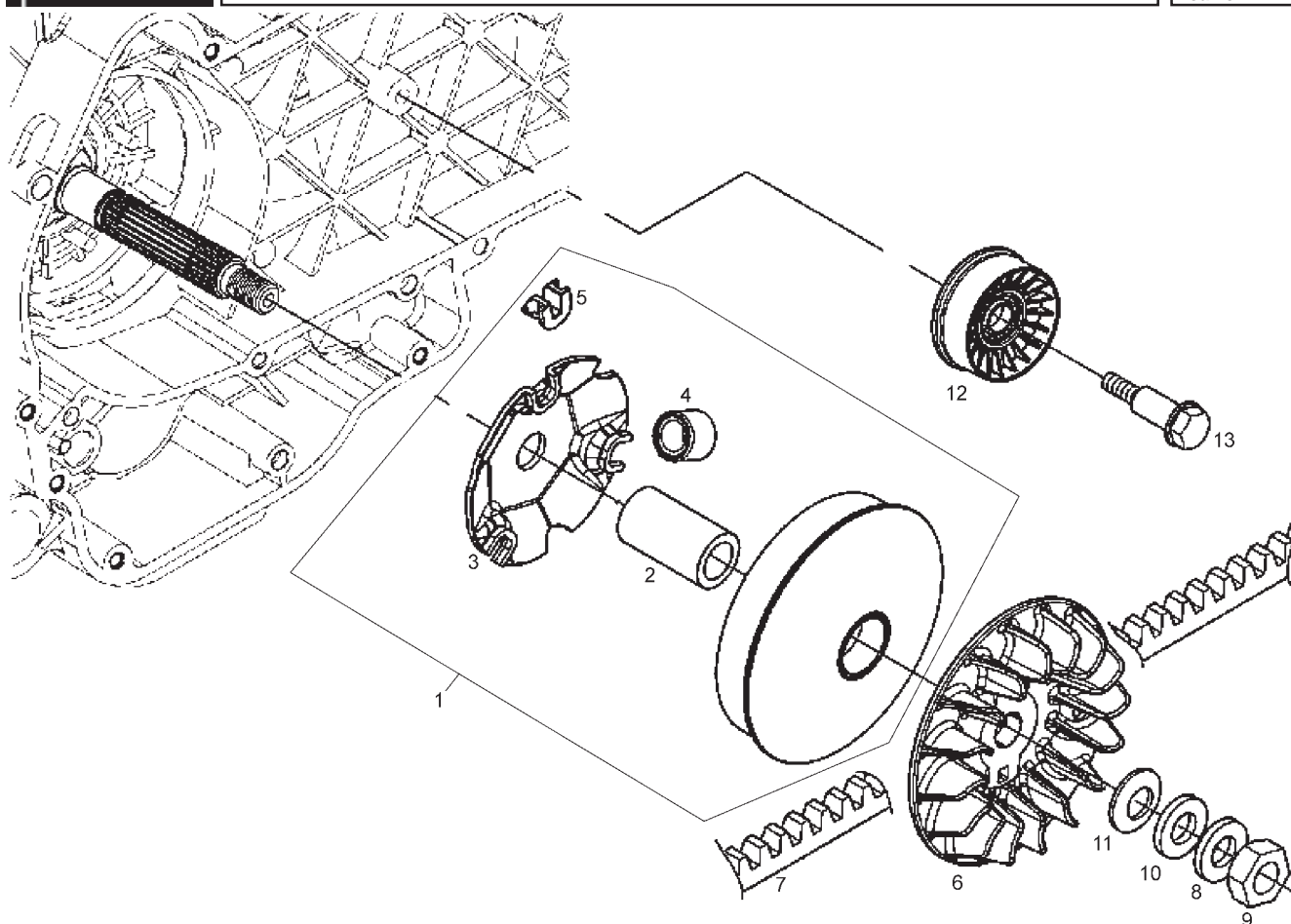

Fig.	Ver.	COD. KOD.	DESCRIPCIÓN DENOMINAZIONE NAME	BEZEICHNUNG DESIGNATION	MOD.	NOTAS NOTES NOTA MITSCHRIFT NOTES
01A		CM144407	CTO VARIADOR ANTERIOR CONTENITORE RULLI COMPLETO PULLEY,HALF	RIEMENSCHIBENHÄLFTE DEMI POULIE	1 2	
02A		483889	DISTANCIADOR DISTANZIALE BUSH	DISTANZHULSE ENTRETOISE	1 2	
03A		842204	PLACA DESLIZAMIENTO MASAS CONTRASTO A RULLI PULLEY,HALF	RIEMENSCHIBENHÄLFTE DEMI POULIE	1 2	
04A		842870	RODILLO RULLO ROLLER	ROLLENKERN ROULEAU	1 2	6 PER BIKE
05A		843028	PATIN PATTINO SHOE	GLEITAUFLAGE DOIGT	1 2	
06A		840193	SEMIPOLEA MOTRIZ SEMIPULEGGIA MOTRICE FISSA PULLEY,HALF	RIEMENSCHIBENHÄLFTE DEMI POULIE	1 2	
07A		843963	CORREA TRAPEZOIDAL CINGHIA TRAPEZOIDALE V-BELT	TRAPEZRIEMEN COURROIE TRAPÉZ	1 2	
08A		434885	ARANDELA RONDELLA WASHER	SCHEIBE RONDELLE	1 2	
09A		486324	TUERCA HEXAGONAL DADO NUT	MUTTER ECROU	1 2	
10A		840533	JUNTA GUARNIZIONE PACKING	DICHTUNG JOINT	1 2	
11A		841379	MUELLE MOLLA A TAZZA SPRING	FEDER RESSORT	1 2	

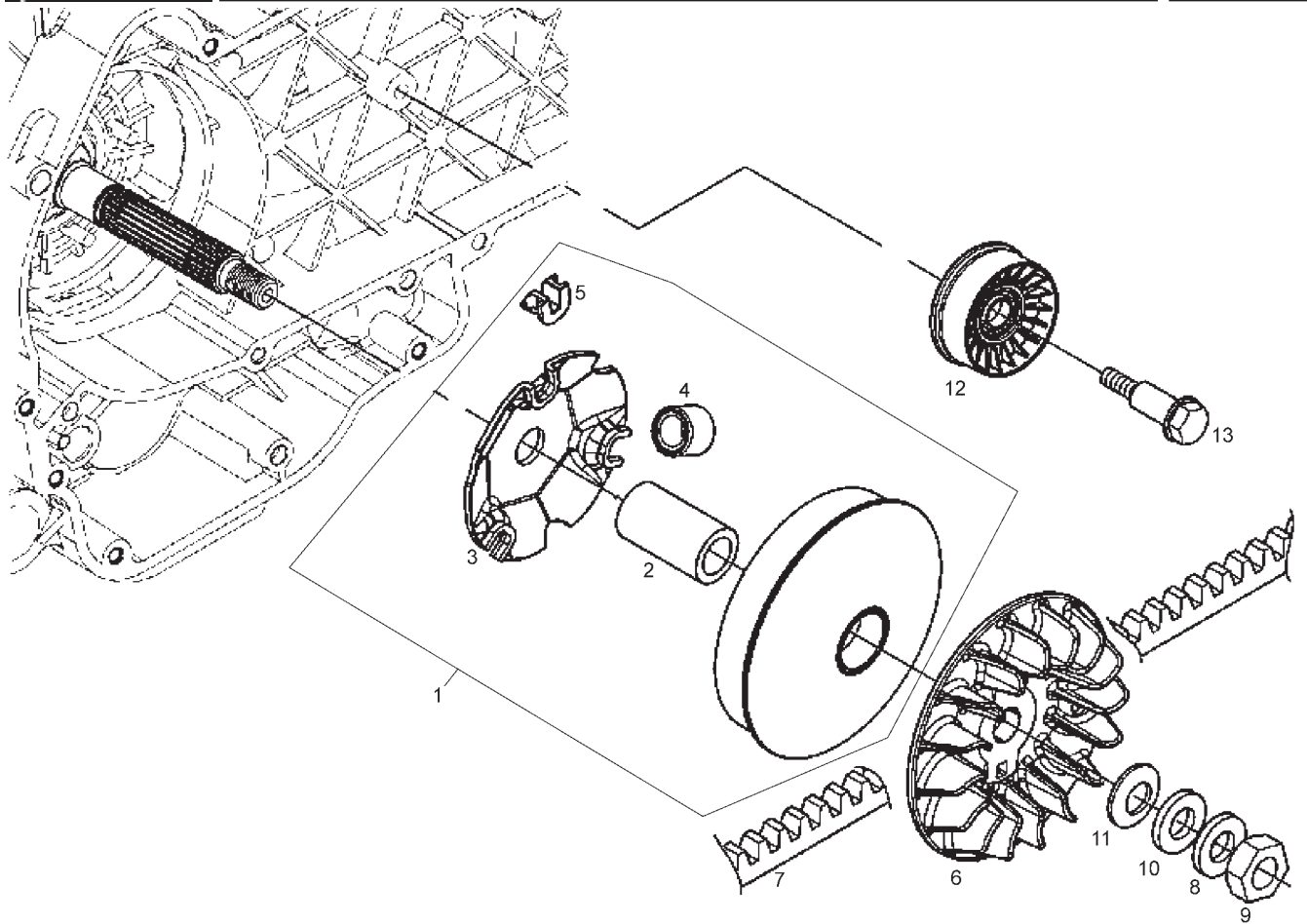

Fig.	Ver.	COD. KOD.	DESCRIPCIÓN DENOMINAZIONE NAME	BEZEICHNUNG DESIGNATION	MOD.	NOTAS NOTES NOTA MITSCHRIFT NOTES
12A		833989	POLEA AMRTGUADOR MOTOR ARRÑQUE PULEGGIA SMORZATORE PULLEY	RIEMENSCHIEBE POULIE	1 2	
13A		828217	TORNILLO ESPECIAL VITE SCREW	SCHRAUBE VIS	1 2	

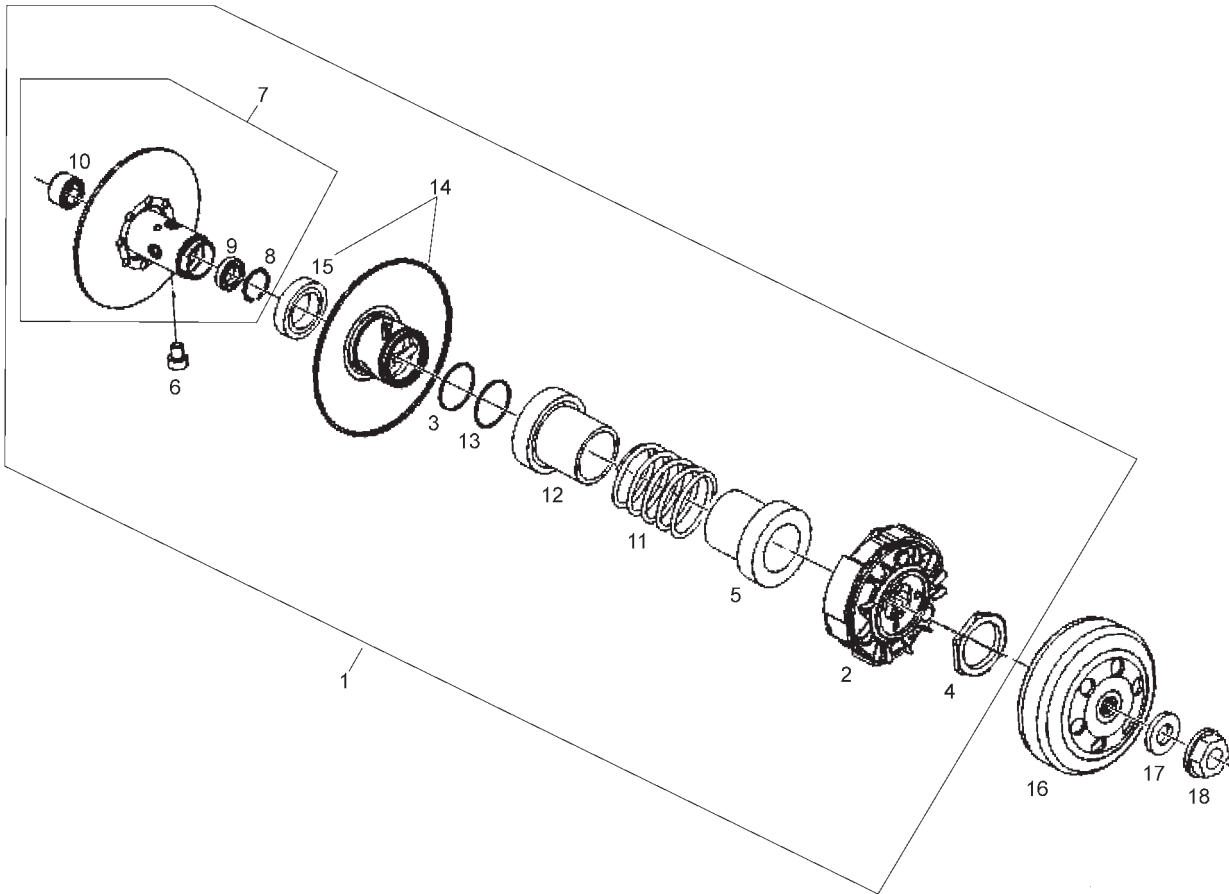

Fig.	Ver.	COD. KOD.	DESCRIPCIÓN DENOMINAZIONE NAME	BEZEICHNUNG DESIGNATION	MOD.	NOTAS NOTES NOTA MITSCHRIFT NOTES
01A		82818R	CTO POLEA CONDUCIDA PULEGGIA CONDOTTA COMPLETA PULLEY	RIEMENSCHLEIBE POULIE	1 2	
02A		CM1440175	GRUPO EMBRAGUE GR. FRIZIONE CENTRIFUGA CLUTCH ASSY	KUPPLUNGBACKEN GR.EMBAYAGE	1 2	
03A		430585	JUNTA GUARNIZIONE PACKING	DICHTUNG JOINT	1 2	
04A		433232	TUERCA GHIERA NUT	MUTTER ECROU	1 2	
05A		487936	CONO LADO EMBRAGUE SCODELLINO LATO FRIZIONE WASHER	SCHEIBE RONDELLE	1 2	
06A		828717	PERNO FIJACION PERNO FRIZIONE PIN	ZAPFEN PIVOT	1 2	
07A		833669	CTO POLEA FIJA SEMIPULEGGIA CONDOTTA FISSA PULLEY,HALF	RIEMENSCHLEIBENHÄLFTE DEMI POULIE	1 2	
08A		483226	ANILLO ELASTICO ANELLO ELASTICO O'RING	RING ANNEAU	1 2	
09A		483261	COJINETE EMBRAGUE CUSCINETTO BEARING	LAGER ROULEMENT	1 2	
10A		82518R	COJINETE AGUJAS EMBRAGUE ASTUCCIO A RULLI BEARING	LAGER ROULEMENT	1 2	
11A		833673	MUELLE VARIADOR MOLLA CONTRASTO VARIATORE SPRING	FEDER RESSORT	1 2	

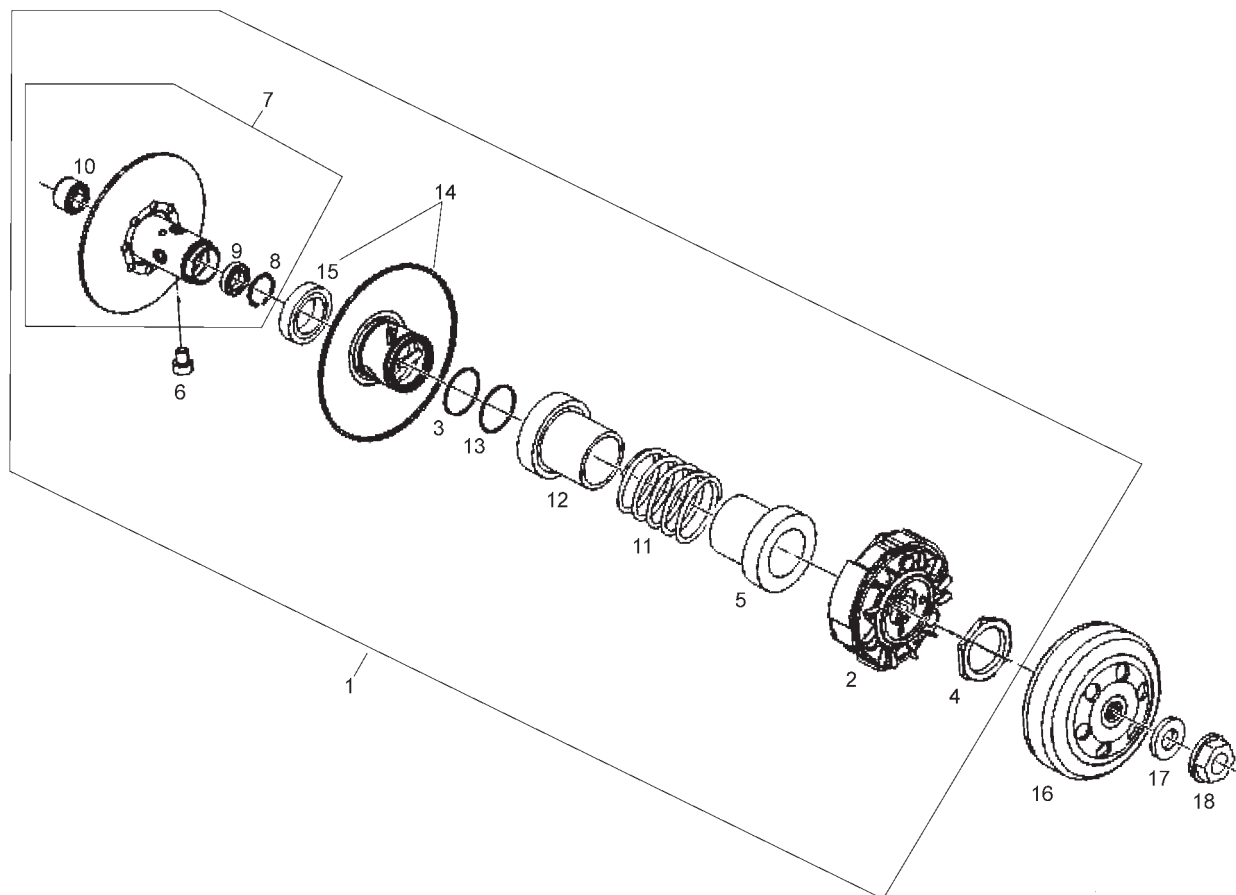

Fig.	Ver.	COD. KOD.	DESCRIPCIÓN DENOMINAZIONE NAME	BEZEICHNUNG DESIGNATION	MOD.	NOTAS NOTES NOTA MITSCHRIFT NOTES
12A		833674	CONO LADO POLEA SCODELLINO LATO PULEGGIA WASHER	SCHEIBE RONDELLE	1 2	
13A		834044	RETEN ANELLO O-RING SEAL	DICHTRING JOINT	1 2	
14A		841774	CTO POLEA MOVIL SEMIPULEGGIA CONDOTTA MOBILE PULLEY,HALF	RIEMENSCHIEBENHÄLFTE DEMI POULIE	1 2	
15A		431089	RETEN ANELLO DI TENUTA SEAL	DICHTRING JOINT	1 2	
16A		8440494	CAMPANA EMBRAGUE TAMBURO FRIZIONE DRUM	TROMMEL TAMBOUR	1 2	
17A		274246	ARANDELA PLANA 12,1x22x1 RONDELLA WASHER	SCHEIBE RONDELLE	1 2	
18A		486324	TUERCA HEXAGONAL DADO NUT	MUTTER ECROU	1 2	

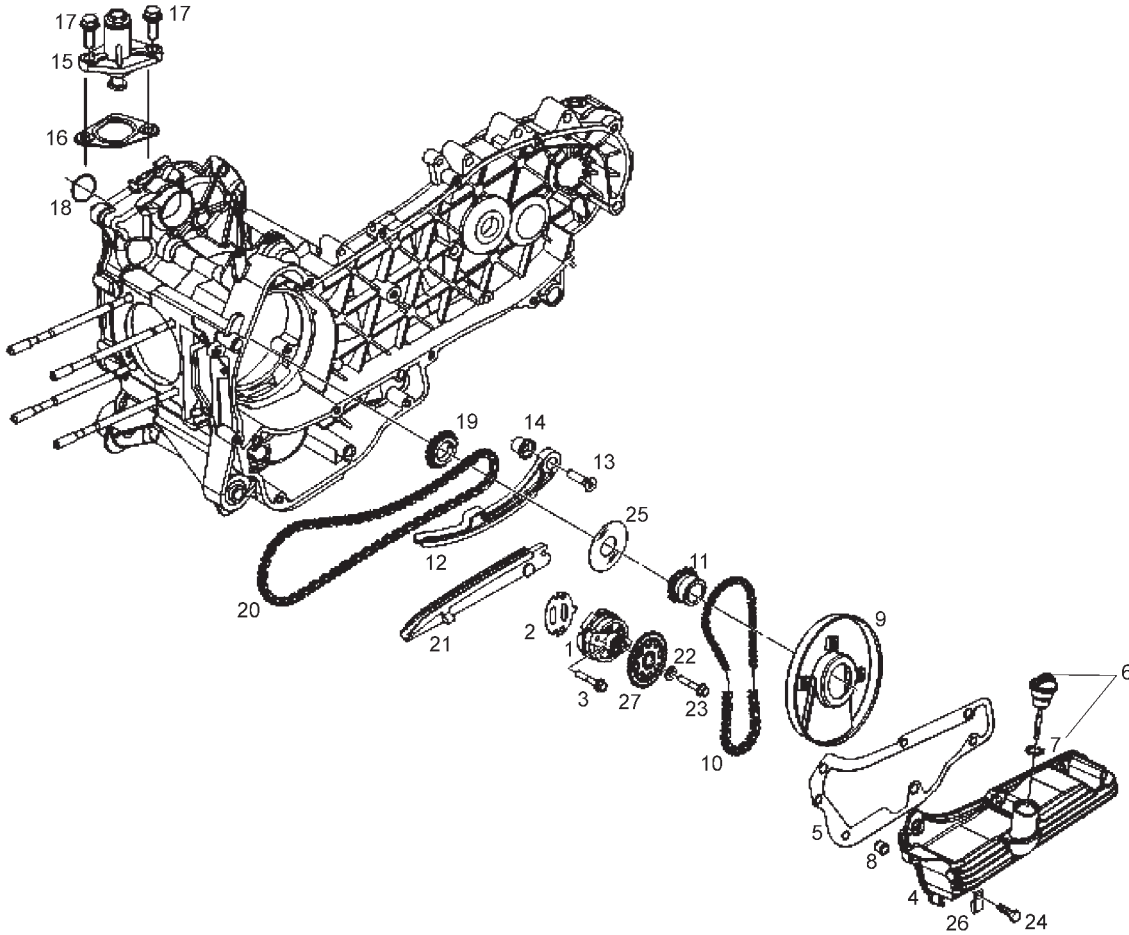

Fig.	Ver.	COD. KOD.	DESCRIPCIÓN DENOMINAZIONE NAME	BEZEICHNUNG DESIGNATION	MOD.	NOTAS NOTES NOTA MITSCHRIFT NOTES
01A		844352	BOMBA ACEITE POMPA OLIO COMPLETA OIL PUMP	ÖLPUMPE POMPE HUILE	1 2	
02A		847929	JUNTA CARTER/BOMBA GUARNIZIONE CARTER/POMPA OLIO PACKING	DICHTUNG JOINT	1 2	
03A		829593	TORNILLO EXAGONAL VITE SCREW	SCHRAUBE VIS	1 2	
04A		846096	CARTER ACEITE COPPA DELL'OLIO MOTORE PAN OIL	ÖLWANNE CARTER À HUILE	1 2	
05A		846098	JUNTA CARTER ACEITE GUARNIZIONE CARTER/COPPA OLIO PACKING	DICHTUNG JOINT	1 2	
06A		846819	TAPON ACEITE TAPPO OLIO COMPLETO CAP	KAPPE BOUCHON	1 2	
07A		479986	JUNTA TORICA GUARNIZIONE O-RING PACKING	DICHTUNG JOINT	1 2	
08A		277916	CENTRAJE 7,5x12 GRANO DI RIFERIMENTO DOWEL	STIFT GOUJON	1 2	
09A		847116	TAPA DISTRIBUCIÓN COPERCHIO DISTRIBUZIONE COVER	DECKEL COUVERCLE	1 2	
10A		82649R	CADENA BOMBA ACEITE CATENA POMPA OLIO CHAIN	KETTE CHAÎNE	1 2	
11A		82783R	PIÑON BOMBA ACEITE PIGNONE COMANDO POMPA PINION	RITZEL PIGNON	1 2	

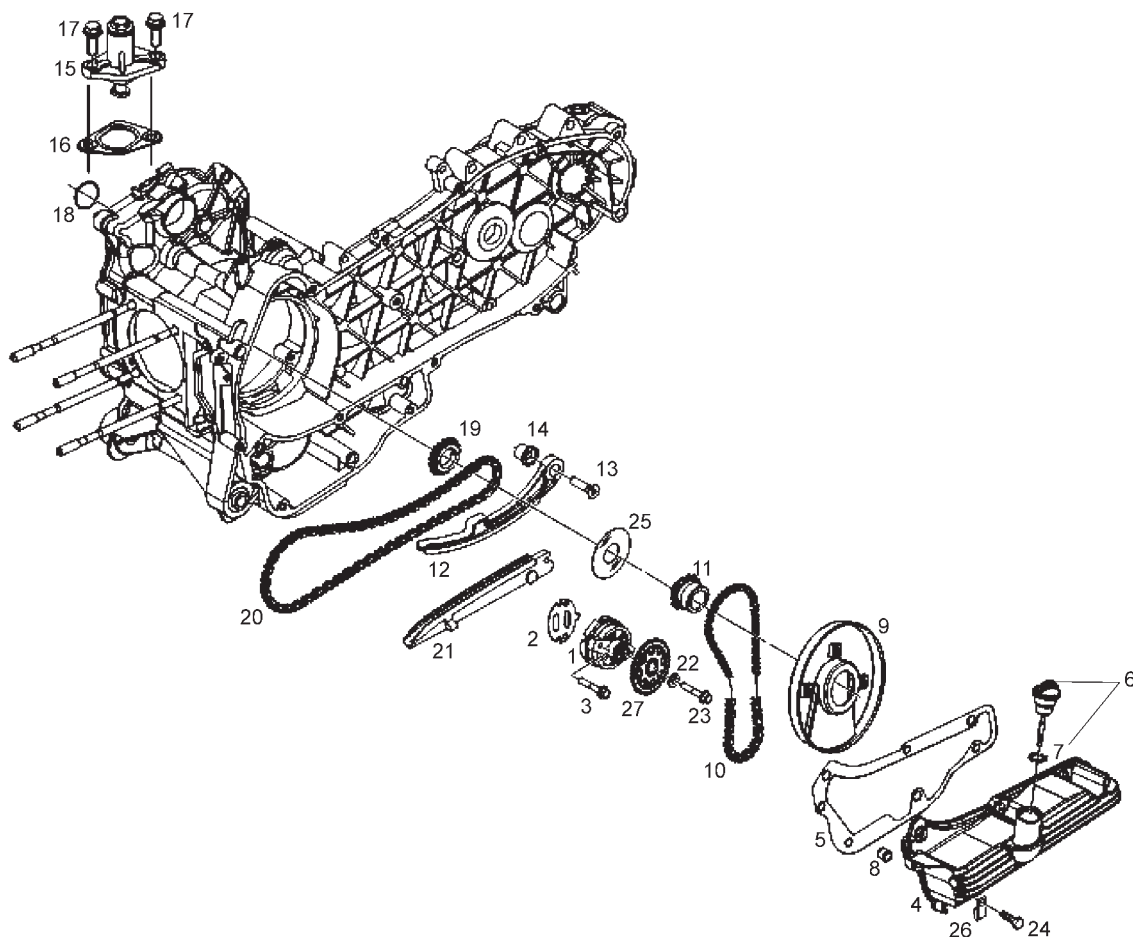

Fig.	Ver.	COD. KOD.	DESCRIPCIÓN DENOMINAZIONE NAME	BEZEICHNUNG DESIGNATION	MOD.	NOTAS NOTES NOTA MITSCHRIFT NOTES
12A		840344	PATIN MOVIL ASTA TENDICATENA SHOE	GLEITAUFLAGE DOIGT	1 2	
13A		414837	TORNILLO M6X25 VITE SCREW	SCHRAUBE VIS	1 2	
14A		485868	CASQUILLO DISTANZIALE ASTA BUSH	DISTANZHULSE ENTRETOISE	1 2	
15A		82650R	TENSOR DE CADENA COMPLESSIVO TENDICATENA TIGHTENER	SPANNER TENDEUR	1 2	
16A		847928	JUNTA GUARNIZIONE CIL./SUPPORTO PACKING	DICHTUNG JOINT	1 2	
17A		434541	TORNILLO M6x16 VITE SCREW	SCHRAUBE VIS	1 2	
18A		825952	ANILLO TORICO ANELLO O-RING O-RING	RING ANNEAU	1 2	
19A		82782R	PIÑÓN DISTRIBUCION PIGNONE DISTRIBUZIONE PINION	RITZEL PIGNON	1 2	
20A		82723R	CADENA DE DISTRIBUCIÓN CATENA DISTRIBUZIONE CHAIN	KETTE CHAÎNE	1 2	
21A		847516	PATIN TENSOR DE CADENA PATTINO FISSO SHOE	GLEITAUFLAGE DOIGT	1 2	
22A		436695	ARANDELA MOLLA A TAZZA WASHER	SCHEIBE RONDELLE	1 2	

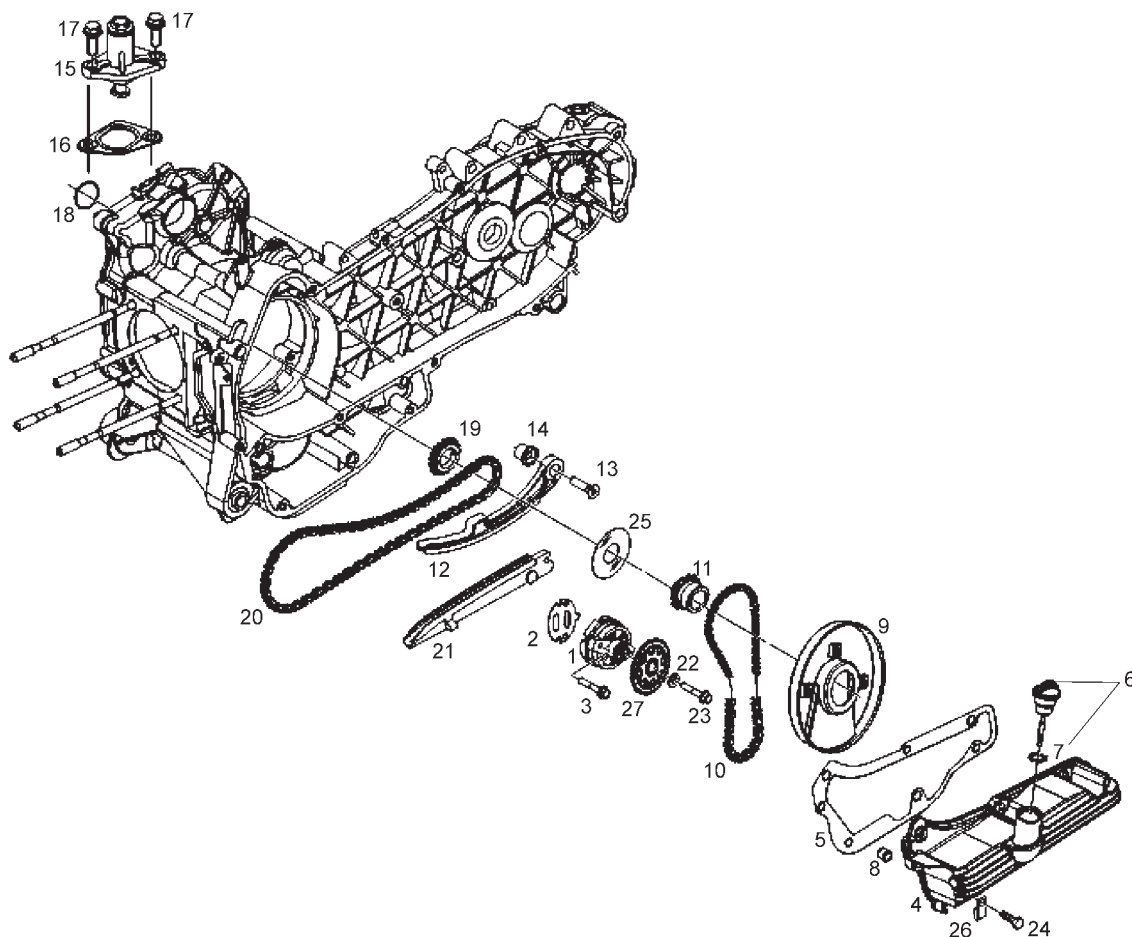

Fig.	Ver.	COD. KOD.	DESCRIPCIÓN DENOMINAZIONE NAME	BEZEICHNUNG DESIGNATION	MOD.	NOTAS NOTES NOTA MITSCHRIFT NOTES
23A		833722	TORNILLO EXAGONAL VITE SCREW	SCHRAUBE VIS	1 2	
24A		289731	TORNILLO M6x30 VITE SCREW	SCHRAUBE VIS	1 2	
25A		483918	ARANDELA DISTRIBUCION RONDELLA PARAOLIO WASHER	SCHEIBE RONDELLE	1 2	
26A		564629	ABRAZADERA FASCETTA CLAMP	SCHELLE COLLIER	1 2	
27A		287913	PIÑÓN BOMBA ACEITE CORONA POMPA OLIO PINION	RITZEL PIGNON	1 2	

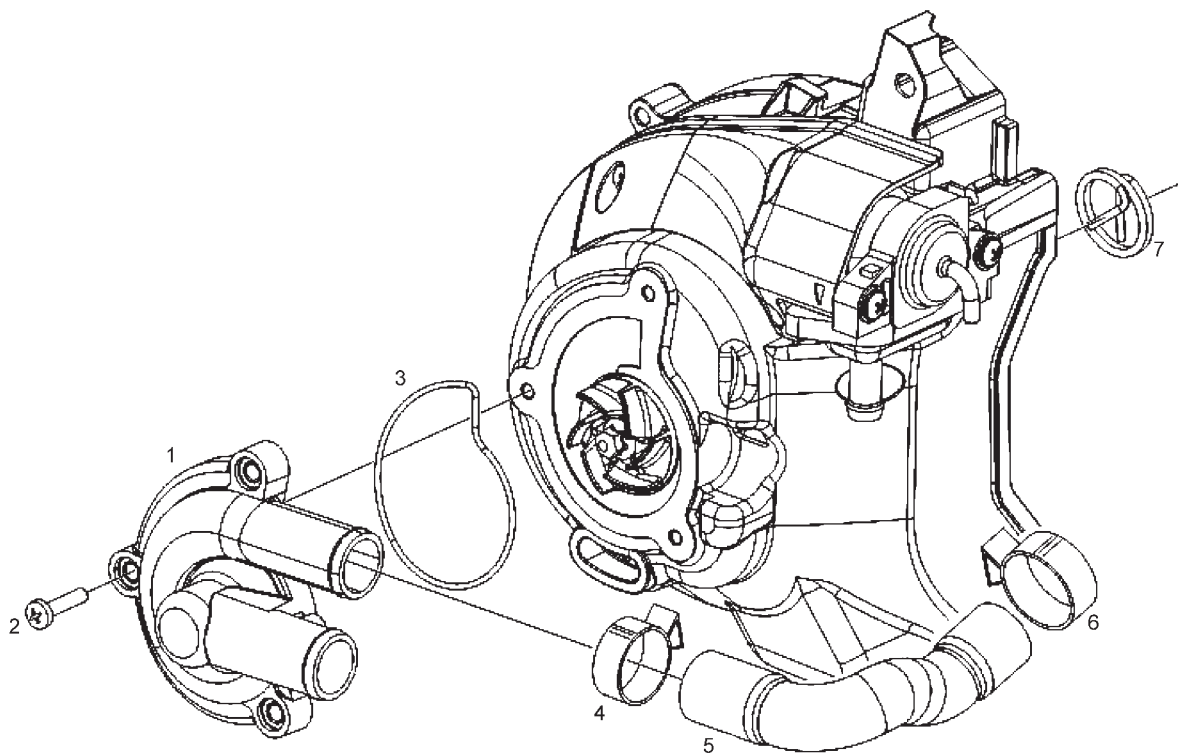

Fig.	Ver.	COD. KOD.	DESCRIPCIÓN DENOMINAZIONE NAME	BEZEICHNUNG DESIGNATION	MOD.	NOTAS NOTES NOTA MITSCHRIFT NOTES
01A		846734	TAPA BOMBA AGUA COPERCHIO POMPA «H2O» COVER	DECKEL COUVERCLE	1 2	
02A		828662	TORNILLO M5X22 VITE SCREW	SCHRAUBE VIS	1 2	
03A		485080	JUNTA TORICA BOMBA AGUA O.R. COPERCHIO POMPA PACKING	DICHTUNG JOINT	1 2	
04A		CM001922	BRIDA FLANGIA CLAMP	BINDER COLLIER	1 2	
05A		841130	MANGUITO BOMBA-CILINDRO TUBO POMPA-CILINDRO SLEEVE	MUFFE MANCHON	1 2	
06A		CM001904	ABRAZADERA FASCETTA STRINGITUBO CLAMP	SHELLE COLLIER	1 2	
07A		842390	MUELLE RETEN BOMBA AGUA MOLLA TRASCINAMENTO GIUNTO SPRING	FEDER RESSORT	1 2	

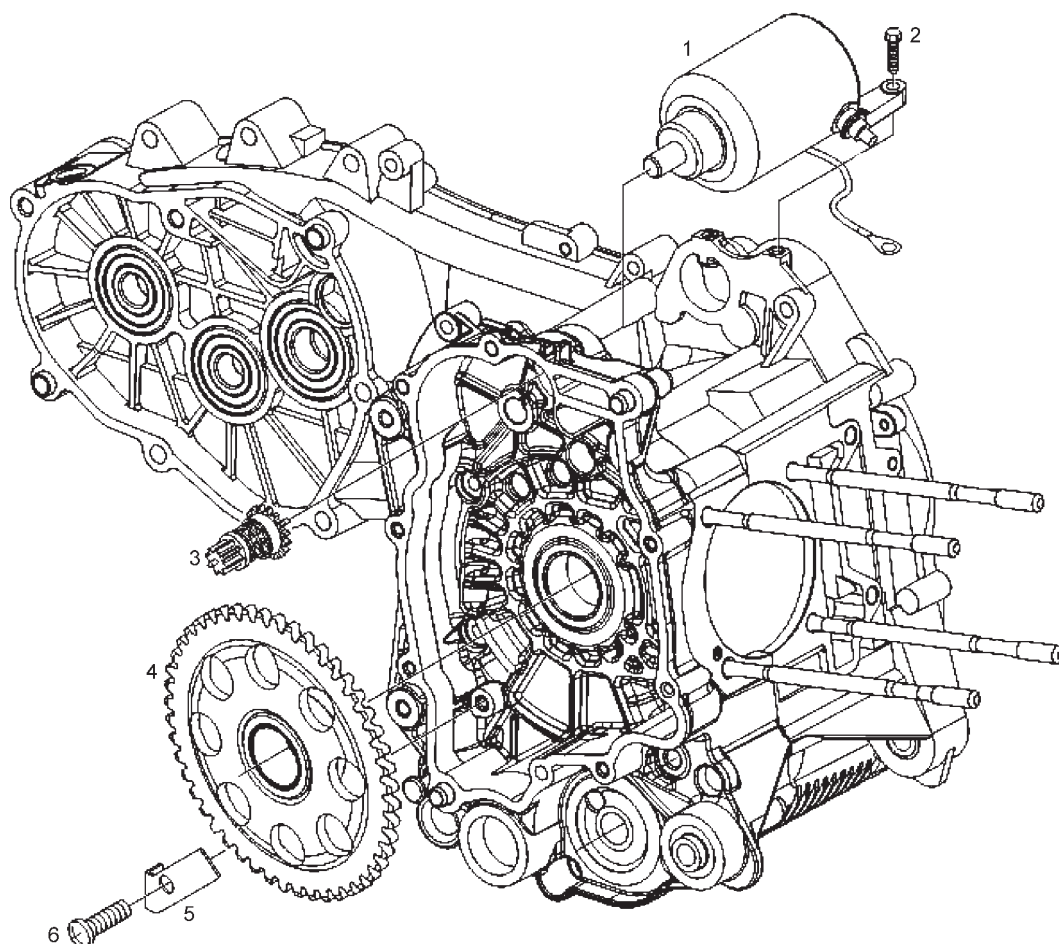

Fig.	Ver.	COD. KOD.	DESCRIPCIÓN DENOMINAZIONE NAME	BEZEICHNUNG DESIGNATION	MOD.	NOTAS NOTES NOTA MITSCHRIFT NOTES
01A		58142R	MOTOR DE ARRANQUE MOTORINO DI AVVIAMENTO MOTOR ASSY	STARTERMOTOR MOTEUR DU DÉMARREUR	1 2	
02A		414837	TORNILLO M6X25 VITE SCREW	SCHRAUBE VIS	1 2	
03A		842703	GRUPO REENVIO GRUPPO RINVIO AVVIAMENTO RETURN UNIT	TACHOANTRIEB RENOI DE ROUE	1 2	
04A		82737R	CORONA ARRANQUE CORONA AVV.ELETTRICO GEAR	GETRIEBE ENGRENAGE	1 2	
05A		848724	PLACA FIJ. CORONA ARRANQUE LAMIERINO RIT.CORONA PLATE	PLÄTTCHEN PLAQUETTE	1 2	
06A		008375	TORNILLO M6X14 VITE SCREW	SCHRAUBE VIS	1 2	

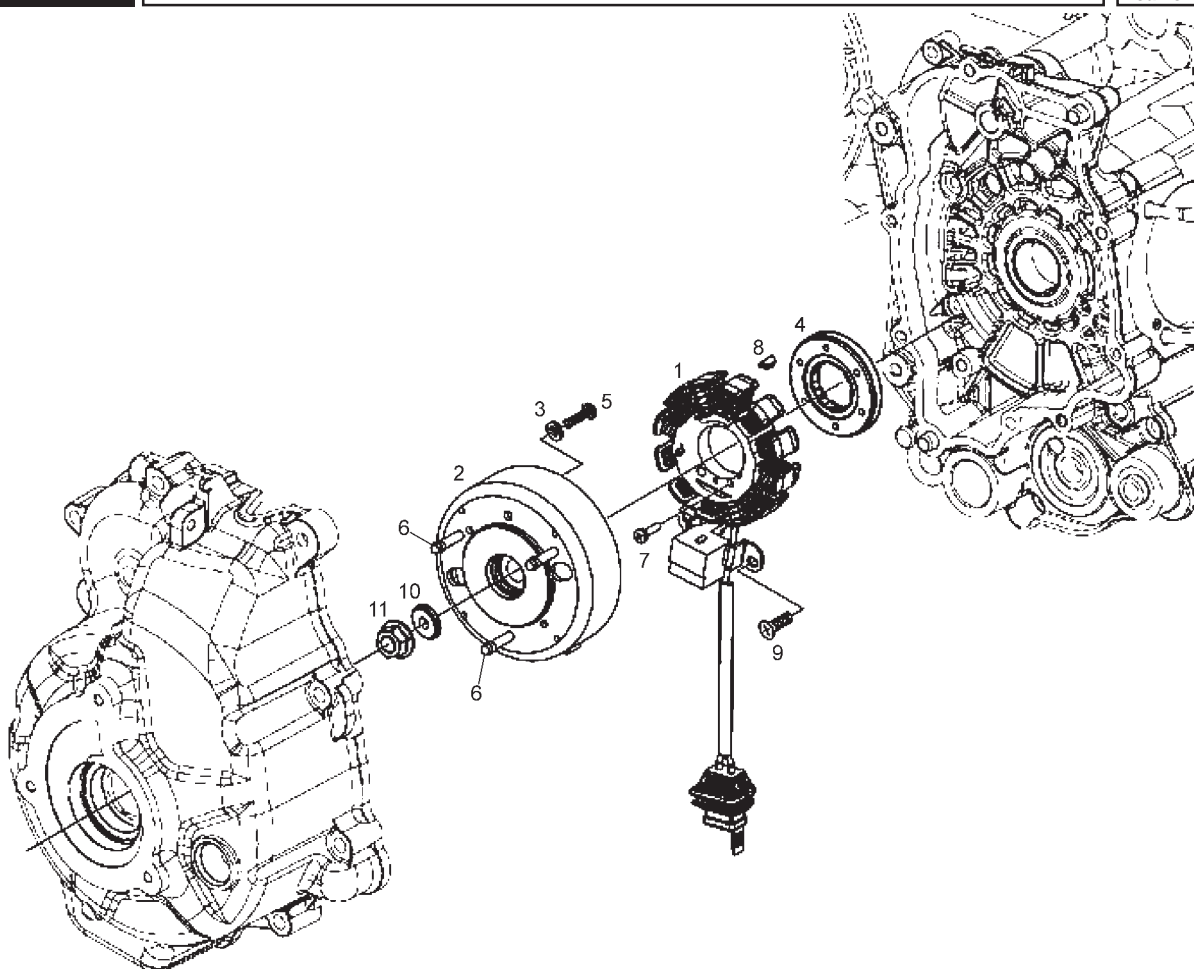

Fig.	Ver.	COD. KOD.	DESCRIPCIÓN DENOMINAZIONE NAME	BEZEICHNUNG DESIGNATION	MOD.	NOTAS NOTES NOTA MITSCHRIFT NOTES
01A		58070R	STATOR STATORE COMPLETO BACKPLATE	ANKERPLATTE STATOR	1 2	
02A		58071R	ROTOR ROTORE COMPLETO ROTOR	ROTOR ROTOR	1 2	
03A		479515	ARANDELA RONDELLA WASHER	SCHEIBE RONDELLE	1 2	
04A		8477975	RUEDA LIBRE RUOTA LIBERA FREE WHEEL	FREIRAD RUOTA LIBRE	1 2	
05A		840893	TORNILLO M6X25 VITE SCREW	SCHRAUBE VIS	1 2	
06A		122637	TORNILLO ALLEN M6X30 VITE SCREW	SCHRAUBE VIS	1 2	
07A		018575	TORNILLO VITE SCREW	SCHRAUBE VIS	1 2	
08A		000097	CHAVETA CHIAVETTA KEY WOODRUFF	KEIL CLAVETTE	1 2	
09A		018575	TORNILLO VITE SCREW	SCHRAUBE VIS	1 2	
10A		842385	ARANDELA RONDELLA WASHER	SCHEIBE RONDELLE	1 2	
11A		842388	TUERCA DADO NUT	MUTTER ECROU	1 2	

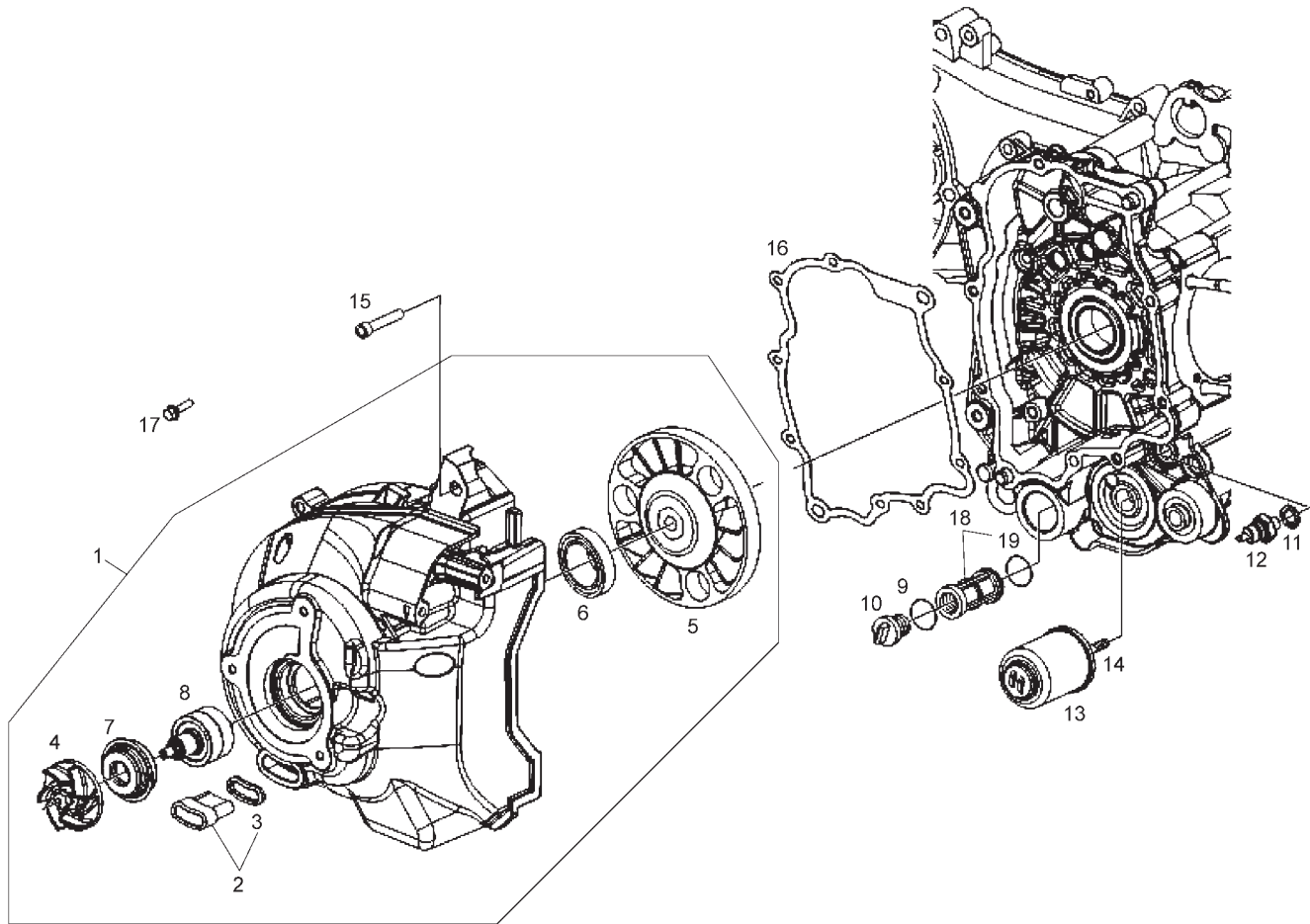

Fig.	Ver.	COD. KOD.	DESCRIPCIÓN DENOMINAZIONE NAME	BEZEICHNUNG DESIGNATION	MOD.	NOTAS NOTES NOTA MITSCHRIFT NOTES
01A		8483785	TAPA VOLANTE MAGNETICO COPERCHIO VOLANO COVER	DECKEL COUVERCLE	1 2	
02A		829040	TAPON DEL ENCENDIDO TAPPO FASATURA CAP	KAPPE BOUCHON	1 2	
03A		479986	JUNTA TORICA GUARNIZIONE O-RING PACKING	DICHTUNG JOINT	1 2	
04A		844730	ROTOR BOMBA AGUA GIRANTE POMPA ACQUA ROTOR	ROTOR ROTOR	1 2	
05A		842389	RETEN ESPECIAL BOMBA AGUA GIUNTO TRASCINAMENTO POMPA SEAL	DICHTRING JOINT	1 2	
06A		82871R	RETEN 20x30x5 ANELLO DI TENUTA SEAL	DICHTRING JOINT	1 2	
07A		842595	RETEN BOMBA AGUA ANELLO DI TENUTA SEAL	DICHTRING JOINT	1 2	
08A		8447595	EJE BOMBA AGUA ALBERO POMPA ACQUA SHAFT	ACHSE ESSIEU	1 2	
09A		285536	JUNTA TAPON ANELLO O-RING PACKING	DICHTUNG JOINT	1 2	
10A		82823R	TAPÓN FILTRO ACEITE TAPPO FILTRO OLIO CAP	KAPPE BOUCHON	1 2	
11A		486075	ARANDELA RONDELLA WASHER	SCHEIBE RONDELLE	1 2	

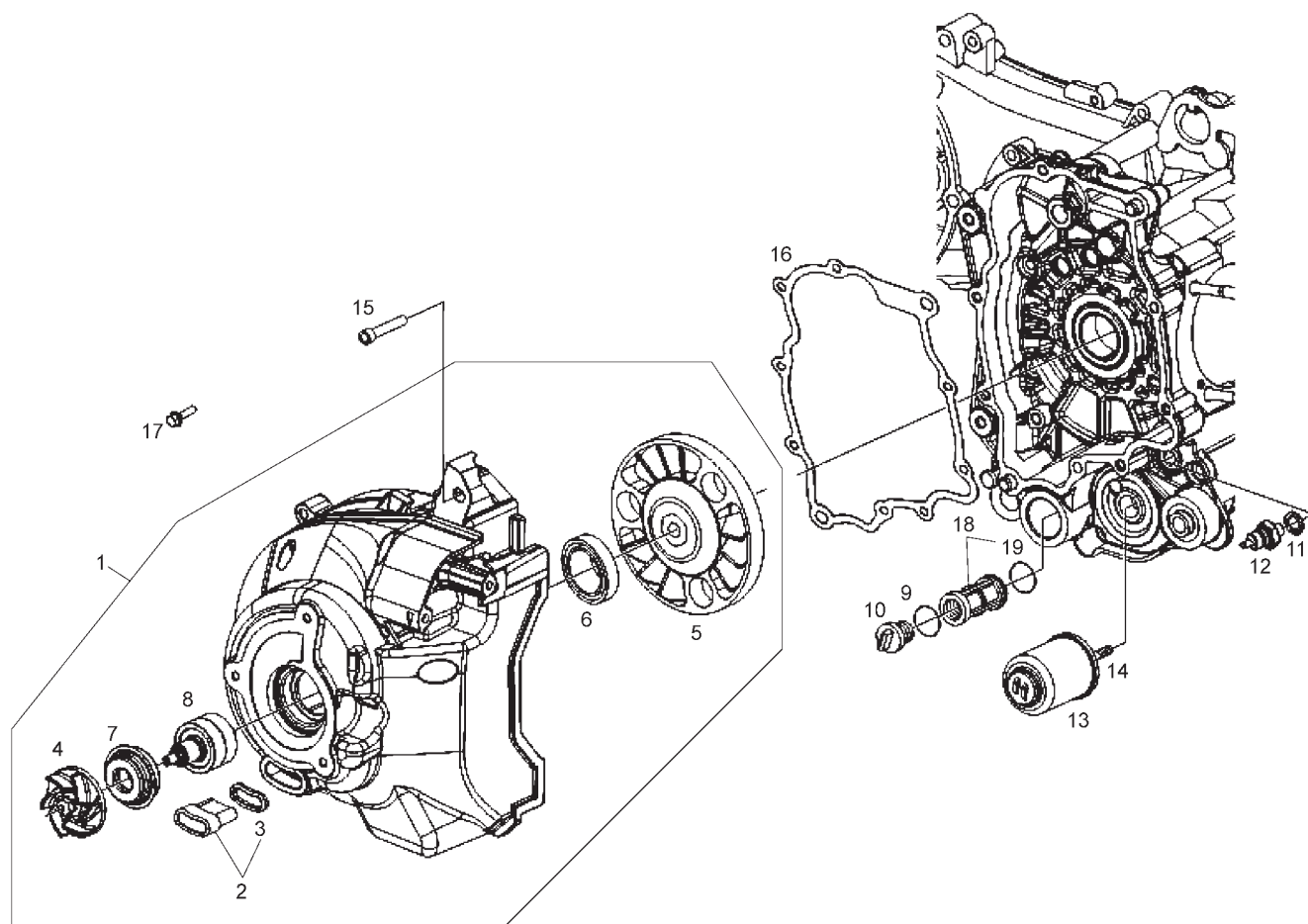

Fig.	Ver.	COD. KOD.	DESCRIPCIÓN DENOMINAZIONE NAME	BEZEICHNUNG DESIGNATION	MOD.	NOTAS NOTES NOTA MITSCHRIFT NOTES
12A		82580R	SENSOR PRESION ACEITE SENSORE MIN.PRESSIONE OLIO SENSOR	SENSOR CAPTEUR	1 2	
13A		82635R	CARTUCHO ACEITE CARTUCCIA OLIO COMPLETO OIL CARTRIDGE	ÖLPATRONE FILTRE À HUILE	1 2	
14A		840507	TORNILLO FILTRO ACEITE VITE SCREW	SCHRAUBE VIS	1 2	
15A		414838	TORNILLO M6X35 VITE SCREW	SCHRAUBE VIS	1 2	
16A		840504	JUNTA TAPA VOLANTE X9 250 EVO GUARNIZIONE COP.VOLANO PACKING	DICHTUNG JOINT	1 2	
17A		844160	TORNILLO M6x110 VITE SCREW	SCHRAUBE VIS	1 2	
18A		843568	FILTRO DE ACEITE FILTRO OLIO ASPIRAZIONE FILTER	FILTER FILTRE	1 2	
19A		288474	JUNTA FILTRO ACEITE ANELLO O-RING PACKING	DICHTUNG JOINT	1 2	

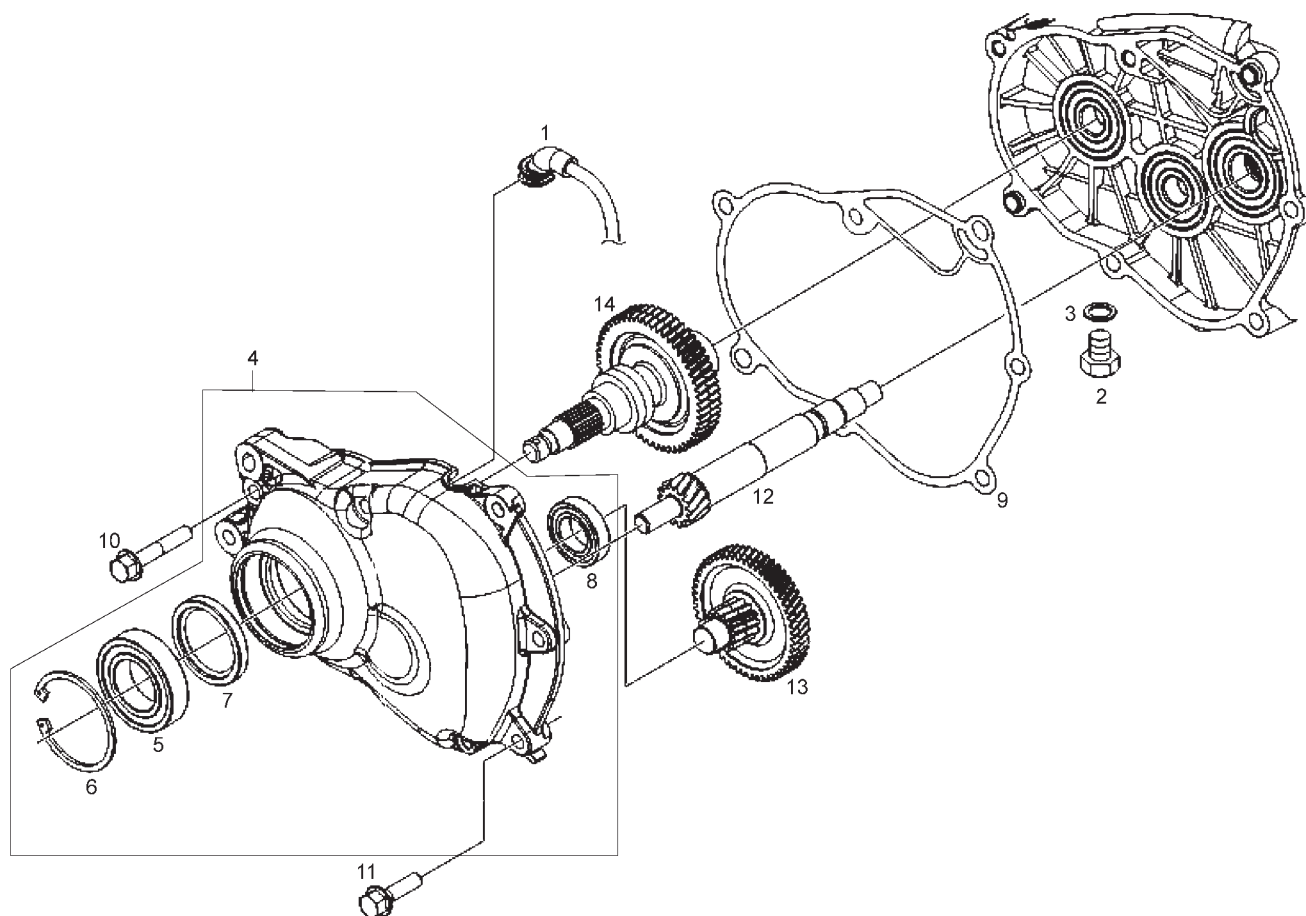

Fig.	Ver.	COD. KOD.	DESCRIPCIÓN DENOMINAZIONE NAME	BEZEICHNUNG DESIGNATION	MOD.	NOTAS NOTES NOTA MITSCHRIFT NOTES
01A		844669	TUBO TUBETTO SFIATO RIDUTTORE BREATHER	ENTLÜFTER RENIFLARD	1 2	
02A		269755	TAPON VACIADO ACEITE VITE CAP	KAPPE BOUCHON	1 2	
03A		485703	JUNTA RONDELLA PACKING	DICHTUNG JOINT	1 2	
04A		8481875	CTO TAPA REDUCTOR COPERCHIO RIDUTTORE COVER	COUVERCLE DECKEL	1 2	
05A		82659R	COJINETE 30x55x13 CUSCINETTO RADIALE BEARING	LAGER ROULEMENT	1 2	
06A		829206	SEGMENTO ANELLO ELASTICO O'RING	RING ANNEAU	1 2	
07A		873351	RETEN EJE RUEDA 38x50x7 ANELLO DI TENUTA SEAL	DICHTRING JOINT	1 2	
08A		485912	COJINETE RADIAL 15.42.1 CUSCINETTO RADIALE BEARING	LAGER ROULEMENT	1 2	
09A		847931	JUNTA TAPA REDUCTOR GUARNIZIONE MOZZO RIDUTTORE PACKING	DICHTUNG JOINT	1 2	
10A		825758	TORNILLO EXAGONAL M8X40 VITE SCREW	SCHRAUBE VIS	1 2	
11A		487211	TORNILLO M8x45 VITE SCREW	SCHRAUBE VIS	1 2	

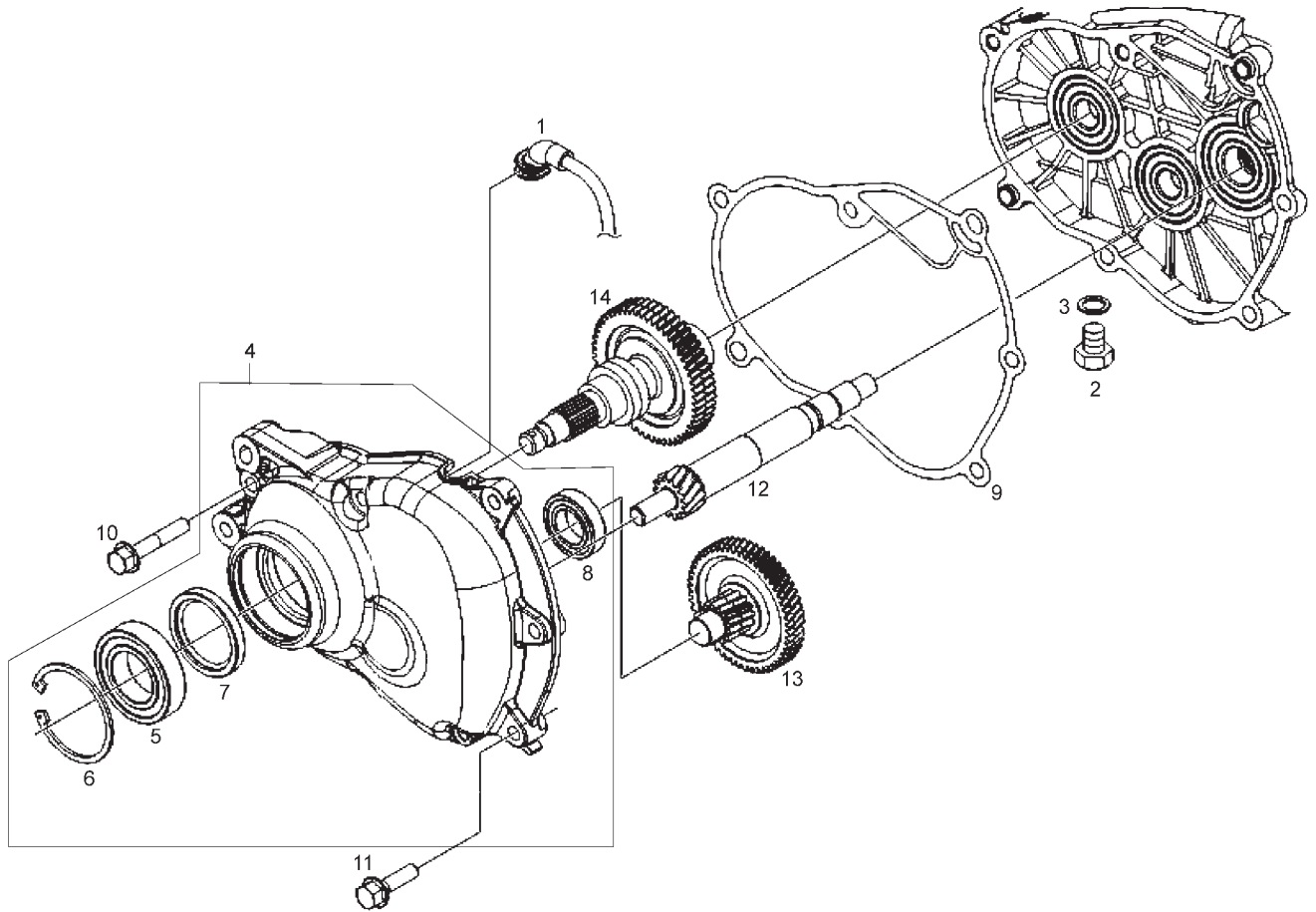

Fig.	Ver.	COD. KOD.	DESCRIPCIÓN DENOMINAZIONE NAME	BEZEICHNUNG DESIGNATION	MOD.	NOTAS NOTES NOTA MITSCHRIFT NOTES
12A		8300715	EJE POLEA ALBERO PULEGGIA CONDOTTA SHAFT	ACHSE ESSIEU	1 2	
13A		8410015	EJE DE REENVIO ALBERO DI RINVIO SHAFT	ACHSE ESSIEU	1 2	
14A		8410035	EJE RUEDA ASSE RUOTA SHAFT	ACHSE ESSIEU	1 2	

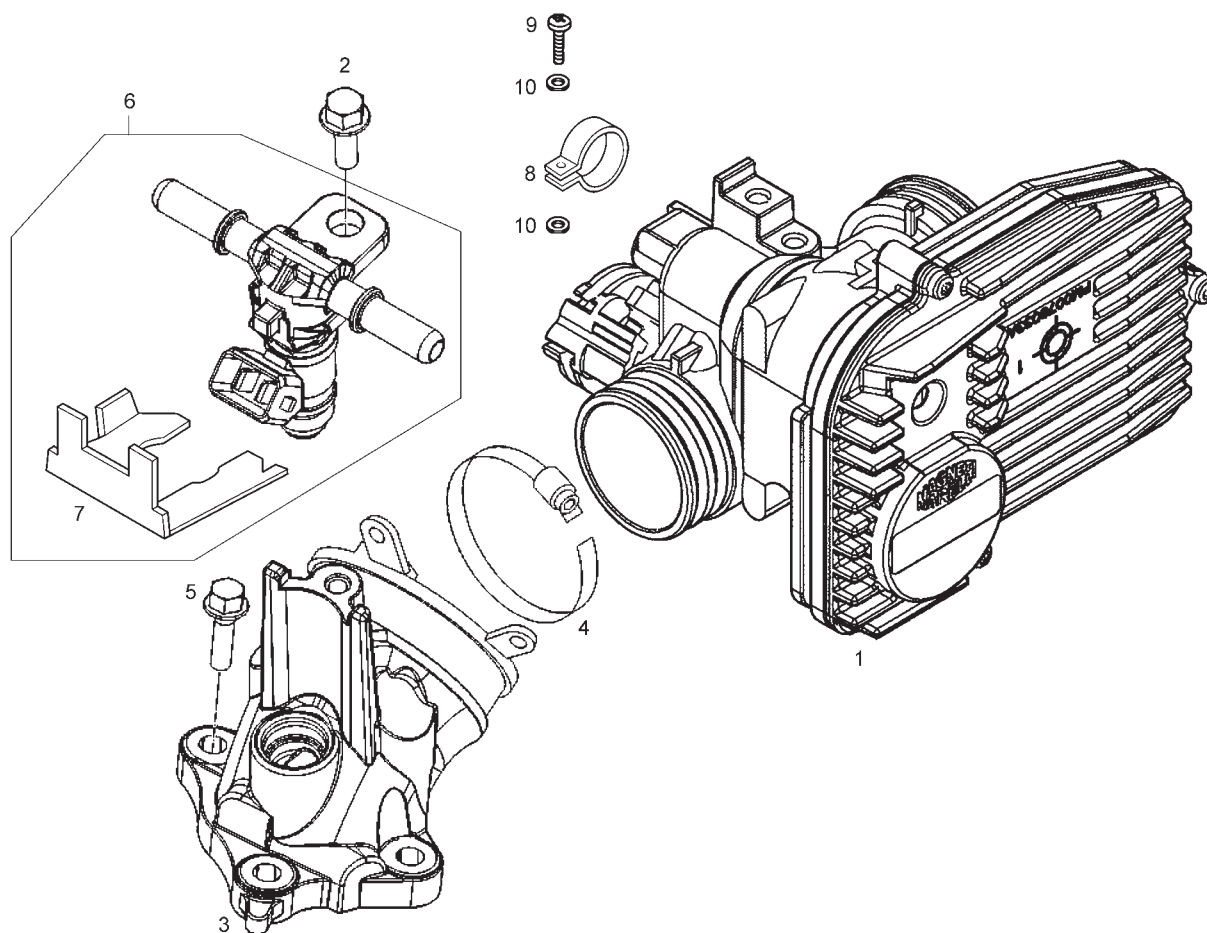

Fig.	Ver.	COD. KOD.	DESCRIPCIÓN DENOMINAZIONE NAME	BEZEICHNUNG DESIGNATION	MOD.	NOTAS NOTES NOTA MITSCHRIFT NOTES
01A		CM078207	CUERPO MARIPOSA CON CDI CORPO FARFAL. CON CENTRALINA BOX	KASTEN CACHON	1 2	
02A		830061	TORNILLO EXAGONAL VITE SCREW	SCHRAUBE VIS	1 2	
03A		872889	RACORD ADMISIÓN RACCORD AMMISSIONE RACORD	RACORD RACCORD	1 2	
04A		709532	ABRAZADERA FASCETTA STRINGITUBO CLAMP	SHELLE COLLIER	1 2	
05A		031091	TORNILLO M6X20 VITE SCREW	SCHRAUBE VIS	1 2	
06A		638949	CTO INYECTOR INIETTORE COMPL.RACCOR INJECTOR	INJEKTOR INJECTEUR	1 2	
07A		829861	SOPORTE INYECTOR STAFFA INIETTORE BRACKET	HALTERUNG SUPPORT	1 2	
08A		638792	BRIDA FIJACION CABLES FLANGIA CLAMP	BINDER COLLIER	1 2	
09A		435295	TORNILLO VITE SCREW	SCHRAUBE VIS	1 2	
10A		00031105000	ARANDELA PLANA D5 RONDELLA WASHER	SCHEIBE RONDELLE	1 2	

Fig.	Ver.	COD. KOD.	DESCRIPCIÓN DENOMINAZIONE NAME	BEZEICHUNG DESIGNATION	MOD.	NOTAS NOTES NOTA MITSCHRIFT NOTES
01A		001467Y014	PINZA DE 15 MM PINZA PER ESTRAZIONE CUSCINETTI 15 MM 15 MM PLIERS		1 2	
02A		020412Y	GUÍA DE 15MM GUIADA DA 15 MM 15 MM GUIDE		1 2	
03A		020565Y	LLAVE DE COMPÁS PARA SUJETAR VOLANTE CHIAVE A COMPASSO FERMO VOLANO COMPASS FLYWHEEL STOP SPANNER		1 2	
04A		020439Y	GUÍA DE 17MM GUIADA DA 17 MM 17 MM GUIDE		1 2	
05A		020359Y	ADAPTADOR 42 X 47MM ADATTATORE 42 X 47 MM 45 X 47 MM ADAPTER		1 2	
06A		020363Y	GUÍA DE 20MM GUIADA DA 20 MM 20 MM GUIDE		1 2	
07A		008564Y	EXTRACTOR DE MAGNÉTO ESTRATTORE VOLANO FLYWHEEL EXTRACTOR		1 2	
08A		020382Y011	BUJE (ÚTIL PARA DESMONTAJE VÁLVULAS) ADATTATORE PER ATTREZZO SMONTAGGIO VALVOLE BUSHING (VALVE REMOVE)		1 2	
09A		020424Y	PUNZÓN MONTAJE COJINETES DE RODILLOS POLEA CONDUCIDA PUNZONE MONTAGGIO ASTUCCIO A RULLI PULEGGIA CONDOTTA DRIVEN PULLEY ROLLER CASTING DRIFT		1 2	
10A		020431Y	EXTRACTOR PARA SELLADORES VÁLVULA ESTRATTORE PER PARAOLIO VALVOLA VALVE OIL SEAL EXTRACTOR		1 2	
11A		020306Y	PUNZÓN MONTAJE SELLADORES VÁLVULA PUNZONE MONTAGGIO ANELLI DI TENUTA VALVOLA VALVE SEALING RING DRIFT		1 2	
12A		020360Y	ADAPTADOR 52 X 55MM ADATTATORE 52 X 55 MM 52 X 55 MM ADAPTER		1 2	
13A		020364Y	GUÍA DE 25MM GUIADA DA 25 MM 25 MM GUIDE		1 2	
14A		020375Y	ADAPTADOR 28 X 30MM ADATTATORE 28 X 30 MM 28 X 30 ADAPTER		1 2	
15A		020376Y	EMPUÑADURA PARA PUNZONES MANICCO PER ADATTATORI HANDLE FOR PUNCHES		1 2	
16A		001467Y035	CAMPANA CAMAPANA PER CUSCINETTI 0 ESTERNO 47 MM BELL		1 2	
17A		020368Y	LLAVE PARA SUJETAR POLEA MOTRIZ CHIAVE D'ARRESTO PULEGGIA MOTRICE DRIVING PULLEY STOP WRENCH		1 2	
18A		020263Y	FUNDA PARA MONTAR SEMI POLEAS GUIANA PER ASSEMBLAGGIO PULEGGIA CONDOTTA PROTECTIVE SHEATH		1 2	
19A		020428Y	SOPORTE PARA CONTROL POSICIÓN DEL PISTÓN SUPPORTO PER CONTROLLO POSIZIONE PISTONE PISTON POSITION CHECK SUPPORT		1 2	
20A		020426Y	HORQUILLA PARA MONTAR PISTÓN FORCELLA PER MONTAGGIO PISTONE PISTON FITTING FORK		1 2	

Fig.	Ver.	COD. KOD.	DESCRIPCIÓN DENOMINAZIONE NAME	BEZEICHNUNG DESIGNATION	MOD.	NOTAS NOTES NOTA MITSCHRIFT NOTES
21A		020425Y	PUNZÓN PARA RETÉN DE ACEITE LADO VOLANTE PUNZONE PER PARAOLIO LATO VOLANO FLYWHEEL-SIDE OIL GUARD PUNCH		1 2	
22A		020423Y	LLAVE PARA SUJETAR CAMPANA EMBRAGUE CHIAVE ARRESTO PULEGGIA CONDOTTA DRIVEN PULLEY STOP KEY		1 2	
23A		020414Y	GUÍA DE 28MM - MONTAJE COJINETES CUBO GUIADA DA 28 MM MONTAGGIO CUSCINETTI MOZZO 28 MM GUIDE - HUB BEARING ASSEMBLY		1 2	
24A		020382Y	ÚTIL PARA DESMONTAR SEMI/CONOS DE VÁLVULAS CON PIEZA 012 ATTREZZO PER RIMOZIONE SEMICONE VALVOLI MINUTO DE PARTICOLARE 012 TOOL TO REMOVE VALVS COTTERS WITH PART 012		1 2	
25A		020455Y	GUÍA DE 10MM GUIADA DA 10 MM 10 MM GUIDE		1 2	
26A		020442Y	LLAVE PARA SUJETAR POLEA MOTRIZ CHIAVE D'ARRESTO PULEGGIA PULLEY STOP WRENCH		1 2	
27A		020440Y	ÚTIL PARA REVISIONAR BOMBA DE AGUA ATTREZZO PER REVISIONE POMPA ACQUA WATER PUMP OVERHAUL TOOL		1 2	
28A		020357Y	ADAPTADOR 32 X 35 MM ADATTATORE 32 X 35 MM 32 X 32 MM ADAPTER		1 2	
29A		020456Y	ADAPTADOR Ø 24MM ADATTATORE 24 MM 24 MM ADAPTER		1 2	
30A		020454Y	ÚTIL PARA MONTAR SUJETADORES DEL BULÓN ATTREZZO PER MONTAGGIO FERMI SPINOTTO (MOTORE 250) PIN RETAINERS INSTALLATION TOOL		1 2	
31A		020622Y	PUNZÓN PARA SELLO DE ACEITE LADO TRANSMISIÓN PUNZONE PARAOLIO LATO TRASMISSIONE TRANSMISSION-SIDE OIL GUARD PUNCH		1 2	
32A		020444Y011	ANILLO ADAPTADOR ANELLA ADATTATORE ADAPTER RING		1 2	
33A		020444Y009	LLAVE 45 X 55 CHIAVE 45 X 55 45 X 55 WRENCH		1 2	
34A		001467Y	CAMPANA ESTRATTORE PER CUSCINETTI PER FORA BELL		1 2	
35A		001467Y013	PINZA DE 15MM PINZA PER ESTRAZIONE CUSCINETTI 15 MM 15 MM PLIERS		1 2	
36A		020444Y008	ANILLO ADAPTADOR ANELLO ADDATTORE ADAPTER RING		1 2	
37A		020244Y	PUNZÓN Ø 15 PUNZONE Ø 15 DRIFT Ø 15		1 2	
38A		020115Y	PUNZÓN Ø 18 PUNZONE Ø 18 DRIFT Ø 18		1 2	
39A		020271Y	HERRAMIENTA PARA DESMONTAJEMONTAJE SILENT-BLOCK ATTREZZO PER SMONTAGGIO-MONTAGGIO SILENI BLOC SILENT-BLOCK INSTALLATION/REMOVAL TOOL		1 2	
40A		020627Y	LLAVE PARA SUJETAR EL VOLANTE MAGNÉTICO CHIAVE ARRESTO VOLANO FLYWHEEL STOP WHEEL		1 2	

Fig.	Ver.	COD. KOD.	DESCRIPCIÓN DENOMINAZIONE NAME	BEZEICHNUNG DESIGNATION	MOD.	NOTAS NOTES NOTA MITSCHRIFT NOTES
41A		020467Y	EXTRACTOR VOLANTE ESTRATTORE VOLANO FLYWHEEL EXTRACTOR		1 2	
42A		020626Y	LLAVE PARA SUJETAR POLEA MOTRIZ CHIAVE DI ARRESTO PULEGGIA MOTRICE DRIVING PULLEY STOP KEY		1 2	
43A		020393Y	COMPRIMIDOR PISTÓN (MOTOR 200-250CC) FASCIA PER MONTAGGIO PISTONE SU CILINDRO (MOTORE 200-250 CC) PISTON BAND CLAMPS (ENGINE 200-250 CC)		1 2	
44A		020287Y	COMPRIMIDOR MONTAJE PISTÓN (MOTOR 125CC) FASCIA PER MONTAGGIO PISTONE SU CILINDRO (MOTORE 125 CC) PISTON BAND CLAMPS (ENGINE 125 CC)		1 2	
45A		020430Y	ÚTIL PARA MONTAR CLIPS DEL PASADOR DEL PISTÓN (MOTOR 125CC) ATTREZZO PER MONTAGGIO FERMI SPINOTTO (MOTORE 125) PIN RETAINERS INSTALLATION TOOL (ENGINE 125CC)		1 2	

CODIGO CODE	Lám. Diagnr.	Figr.	Vers.	CODIGO CODE	Lám. Diagnr.	Figr.	Vers.	CODIGO CODE	Lám. Diagnr.	Figr.	Vers.	CODIGO CODE	Lám. Diagnr.	Figr.	Vers.
00000002825	01	23A		00008051600	07	09A		00113031060	05	13A		00D03700131	04	34A	
00000004160	11	14A		00008051600	07	24A		001467Y	34	34A		00D05900031	10	39A	
00000004512	09	15A		00008061500	05	45A		001467Y013	34	35A		00D05900081	04	29A	
00000004512	09	24A		00008061500	07	40A		001467Y014	34	01A		00F00900531	10	54A	
00000004515	10	36A		00008061500	16	05A		001467Y035	34	16A		00F01500381	09	34A	
00000004515	10	61A		00008062000	05	04A		00232160021	12	07A		00F05900041	06	08A	
00000004635	10	65A		00008062000	07	37A		00262080022	14	20A		00F05900041	06	17A	
00000004650	18	16A		00008062000	16	04A		00262100032	03	04A		00F05900041	07	07A	
00000004660	18	13A		00008063001	12	14A		00262100032	03	08A		00F05900041	07	16A	
00000004825	01	07A		00008915020	04	05A		00262100032	03	14A		00F05900041	10	31A	
00000004850	03	10A		000097	30	08A		00281141503	14	04A		00F05900091	07	03A	
00000021030	10	59A		00011031001	05	20A		003751	02	16A		00G00100711	01	28A	
00000023040	07	32A		00011031001	05	35A		00402030001	10	22A		00G00102381	14	05A	
00000023060	04	07A		00011031001	06	14A		00402060001	04	03A		00G00104831	14	11A	
00000023060	05	06A		00011031001	08	18A		00402060001	07	44A		00G00200761	01	05A	
00000023060	05	33A		00011031401	05	15A		00402060001	10	66A		00G00300701	14	06A	
00000023060	15	06A		00011031401	07	05A		00402060001	15	05A		00G00300811	14	12A	
00000023060	18	19A		00011031401	07	20A		00402060001	18	18A		00G00308401	14	16A	
00000023080	01	26A		00011031401	07	26A		00402080001	01	08A		00G00401681	06	23A	
00000023080	09	04A		00011031401	07	28A		00402080001	01	21A		00G00402131	04	26A	
00000023100	14	10A		00011031401	10	05A		00402080001	01	32A		00G00601141	15	15A	
00000023100	14	15A		00011031401	10	10A		00402080001	03	11A		00G00604181	15	13A	
00000031040	05	21A		00011031401	10	18A		00402080001	03	18A		00G00607162	07	04A	
00000031050	04	23A		00011131401	08	02A		00402080001	03	34A		00G00607163	07	04B	
00000031050	05	24A		00011131401	08	11A		00402080001	12	18A		00G00701051	05	02A	
00000031050	05	36A		00011141300	04	25A		00402080001	13	11A		00G00715022	05	01A	
00000031050	05	42A		00011142500	06	03A		00402080001	14	19A		00G00715023	05	01B	
00000031050	05	44A		00011941300	08	20A		00402100001	03	03A		00G00903201	09	11A	
00000031050	06	25A		00011942000	05	43A		00402100001	03	07A		00G00903201	09	20A	
00000031050	06	28A		00012051200	08	08A		00402100001	03	13A		00G00909071	09	05A	
00000031050	06	34A		00012051200	08	16A		00402100001	03	30A		00G00910011	09	01A	
00000031050	06	39A		00012061200	15	11A		00402100001	14	09A		00G00910081	09	07A	
00000031050	06	43A		00012151500	04	22A		00402100001	14	14A		00G01016521	08	01A	
00000031050	07	13A		00012151500	05	23A		00442080002	01	15A		00G01026011	10	02B	
00000031050	07	21A		00012151500	05	40A		00442080002	01	18A		00G01027011	10	03B	
00000031050	08	03A		00012151500	06	24A		00452080002	01	12A		00G01201291	11	07A	
00000031050	10	06A		00012151500	06	27A		006635	17	05A		00G01215111	11	02A	
00000031050	10	37A		00012151500	06	38A		00702009321	12	09A		00G01403411	01	13A	
00000031050	10	62A		00012162000	05	08A		008375	29	06A		00G01403411	01	25A	
00000031080	09	03A		00012162000	06	11A		008564Y	34	07A		00G01500021	15	08A	
00000033080	12	12A		00012162000	08	04A		00A00900531	10	52A		00G01501431	14	17A	
00000061061	01	38A		00022147071	14	02A		00D00900531	10	53A		00G01501651	08	10A	
00002062011	08	12A		00023108000	01	09A		00D01200171	01	40A		00G01501901	07	33A	
00002062011	15	04A		00023108000	01	19A		00D01200171	18	14A		00G01502451	06	07A	
00002062511	04	02A		00023108000	01	30A		00D01200171	18	17A		00G01503681	05	37A	
00002064011	18	12A		00023108000	01	33A		00D01500471	04	06A		00G01505352	05	07A	
00002082021	01	20A		00023108000	03	19A		00D01500552	04	04A		00G01505353	05	07B	
00002082021	14	18A		00026006001	12	15A		00D01501371	04	15A		00G01506751	08	15A	
00002083001	12	17A		00026008001	01	14A		00D01501371	04	30A		00G01507091	06	06A	
00002083001	13	10A		00026008001	03	12A		00D01501371	05	10A		00G01508232	06	15A	
00002084514	03	33A		00026008001	01	16A		00D01501371	05	38A		00G01508233	06	15B	
00002105511	03	06A		00031008000	01	24A		00D01501371	06	05A		00G01602581	08	23A	
00004154000	09	31A		00031105000	33	10A		00D01501371	06	09A		00G01700531	10	25A	
00004163500	07	31A		00031106000	05	09A		00D01501371	06	13A		00G01700541	10	26A	
00004184001	01	17A		00031106000	05	34A		00D01501371	06	18A		00G01706021	10	19A	
00004184500	01	11A		00031106000	06	12A		00D01501371	07	08A		00G01706311	10	20A	
00004184500	09	02A		00031106000	07	39A		00D01501371	07	17A		00G01800021	05	11A	
00004283500	01	29A		00031106000	07	41A		00D01501371	08	06A		00G01800031	05	12A	
00005010760	09	29A		00031106000	08	05A		00D01501371	08	14A		00G01800121	16	03A	
00006105000	03	02A		00031106000	15	12A		00D01501371	10	32A		00G01802361	10	49A	
00006309260	09	16A		00032015000	11	08A		00D01501371	16	07A		00G02102631	09	09A	
00006309260	09	25A		00032015000	14	03A		00D01501371	18	15A		00G02300581	10	17A	
00006321040	09	17A		00047030400	01	27A		00D02600631	07	10A		00G02301991	10	56A	
00006321040	09	26A		00052062011	11	13A		00D02600631	07	38A		00G02304171	09	06A	
00008051200	05	16A		000674	19	12A		00D02600631	08	21A		00G02400111	12	08A	
00008051200	06	33A		00112031060	10	21A		00D02600631	10	11A		00G03000211	05	32A	
00008051200	07	12A		00112031560	10	23A		00D03400521	04	10A		00G03001091	07	36A	
00008051600	06	42A		00112031560	10	27A		00D03400521	04	18A		00G03001271	14	08A	

CODIGO CODE	Lám. Diagr.	Figr.	Vers.	CODIGO CODE	Lám. Diagr.	Figr.	Vers.	CODIGO CODE	Lám. Diagr.	Figr.	Vers.	CODIGO CODE	Lám. Diagr.	Figr.	Vers.
00G03002271	14	13A		00H01002911	10	33A		020423Y	34	22A		435629	22	20A	
00G03304401	10	28A		00H01003131	10	42A		020424Y	34	09A		436438	22	14A	
00G03702461	04	33A		00H01003131	10	51A		020425Y	34	21A		436695	27	22A	
00G03800401	05	19A		00H01003951	10	13A		020426Y	34	20A		436919	10	47A	
00G03800471	04	16A		00H01004131	10	04B		020428Y	34	19A		436947	13	08A	
00G03801701	04	12A		00H01011321	10	12A		020430Y	34	45A		478115	19	15A	
00G03802041	04	19A		00H01023011	10	02A		020431Y	34	10A		478115	21	10A	
00G03802091	04	17A		00H01024011	10	03A		020439Y	34	04A		478184	21	11A	
00G03802091	04	32A		00H01201331	11	10A		020440Y	34	27A		478985	17	04A	
00G03802301	05	18A		00H01301831	12	16A		020442Y	34	26A		479515	30	03A	
00G03803301	05	26A		00H01304931	12	04A		020444Y008	34	36A		479986	27	07A	
00G03803501	04	13A		00H01500691	04	24A		020444Y009	34	33A		479986	31	03A	
00G03804301	05	30A		00H01500691	10	63A		020444Y011	34	32A		480853	22	01A	
00G03805011	04	01A		00H01500741	05	27A		020454Y	34	30A		482282	13	05A	
00G03900821	17	15A		00H01503701	05	03A		020455Y	34	25A		483226	26	08A	
00G04400971	06	21A		00H01507091	01	34A		020456Y	34	29A		483261	26	09A	
00G04400981	06	22A		00H01507451	01	35A		020467Y	34	41A		483711	22	15A	
00G04401462	05	17A		00H01602941	08	22A		020565Y	34	03A		483767	19	22A	
00G04401462	05	25A		00H01701011	10	24A		020622Y	34	31A		483785	19	09A	
00G04401462	05	41A		00H01801411	15	09A		020626Y	34	42A		483889	25	02A	
00G04401462	06	26A		00H02100901	09	14A		020627Y	34	40A		483914	22	16A	
00G04401462	06	29A		00H02100901	09	23A		030115	03	28A		483918	27	25A	
00G04401462	06	35A		00H02202301	01	31A		031091	33	05A		484034	19	05A	
00G04401462	06	40A		00H02300961	10	41A		063435	22	05A		484123	23	11A	
00G04401462	07	11A		00H03200271	18	08A		071671	10	44A		4847395	23	01A	
00G04401462	07	14A		00H03806091	04	20A		077023	01	41A		4847405	23	04A	
00G04401462	07	25A		00H04400711	10	67A		077024	01	04A		484819	23	02A	
00G04401462	08	09A		00H04401711	06	45A		122637	30	06A		484819	23	05A	
00G04401462	08	17A		00H04402601	10	50A		168077	04	09A		484908	21	05A	
00G04401462	10	38A		00H04702121	09	21A		232108	03	29A		485047	19	23A	
00G04402751	07	43A		00H04702121	12	19A		239388	17	06A		485080	28	03A	
00G04403771	06	19A		00H04705121	11	16A		239388	19	03A		485655	19	27A	
00G04403781	06	20A		00H04901411	07	06A		239388	19	06A		485703	32	03A	
00G04702091	11	03A		00H04902291	01	39A		258146	17	13A		485868	27	14A	
00G04702091	12	03A		00H04902311	01	36A		258146	18	04A		485912	19	07A	
00G04902731	01	22A		00H04903401	01	37A		269755	32	02A		485912	32	08A	
00G04907761	05	14A		00H05701471	10	08A		270793	17	10A		486075	31	11A	
00G05107561	15	02A		00H05703471	10	09A		273754	03	27A		486081	19	10A	
00G05601201	09	13A		00H05704471	10	07A		274246	26	17A		486324	25	09A	
00G05700551	04	21A		00H05900021	04	14A		277916	19	19A		486324	26	18A	
00G05700641	10	40A		00H05900021	06	44A		277916	21	09A		486331	23	14A	
00G05701471	10	16A		00H06300861	06	04A		277916	27	08A		486336	23	08A	
00G05703141	05	29A		00K05110651	07	30A		285536	31	09A		486343	23	07A	
00G05900711	08	13A		00N05700711	10	60A		285846	22	13A		486363	21	04A	
00G05905911	05	22A		011109	02	17A		287913	27	27A		486974	23	15A	
00G05905941	07	02A		018538	23	13A		288474	31	19A		487211	32	11A	
00G05906911	06	32A		018575	19	17A		289731	17	11A		487665	13	06A	
00G05907911	06	30A		018575	30	07A		289731	27	24A		487832	23	16A	
00G05908911	06	31A		018575	30	09A		293845	10	46A		487833	23	17A	
00G05909251	15	03A		020115Y	34	38A		294828	10	30A		487936	26	05A	
00G05911911	05	39A		020244Y	34	37A		297027	22	06A		487989	24	06A	
00G06101181	07	22A		020263Y	34	18A		327187	11	05A		497069	16	02A	
00G06101191	07	23A		020271Y	34	39A		411296	22	09A		497070	16	01A	
00G06200051	04	27A		020287Y	34	44A		411311	19	04A		56002R	01	02A	
00G06300671	05	28A		020306Y	34	11A		414837	27	13A		56003R	01	03A	
00G06301551	07	18A		020357Y	34	28A		414837	29	02A		56391R	12	13A	
00G06801501	15	10A		020359Y	34	05A		414838	23	09A		564629	27	26A	
00G06816322	06	16A		020360Y	34	12A		414838	31	15A		576542	04	37A	
00G06816323	06	16B		020363Y	34	06A		430264	17	08A		576546	04	36A	
00H00300672	11	09A		020364Y	34	13A		430585	26	03A		58070R	30	01A	
00H00600681	15	14A		020368Y	34	17A		431065	19	26A		58071R	30	02A	
00H00700321	05	05A		020375Y	34	14A		431089	26	15A		58120R	10	43A	
00H00717341	07	29A		020376Y	34	15A		431860	17	03A		58142R	29	01A	
00H00800421	03	17A		020382Y	34	24A		432142	19	20A		581560	03	26A	
00H00805072	03	16A		020382Y011	34	08A		433232	26	04A		582298	03	23A	
00H01000681	10	15A		020393Y	34	43A		434541	27	17A		582850	03	24A	
00H01001371	10	14A		020412Y	34	02A		434885	25	08A		582851	03	25A	
00H01002131	10	04A		020414Y	34	23A		435295	33	09A		584344	13	13A	

CODIGO CODE	Lám. Diagn.	Figr.	Vers.	CODIGO CODE	Lám. Diagn.	Figr.	Vers.	CODIGO CODE	Lám. Diagn.	Figr.	Vers.	CODIGO CODE	Lám. Diagn.	Figr.	Vers.
584521	10	35A		831174	22	10A		847116	27	09A		86446200W07	09	30A	
584533	10	64A		832130	19	11A		847516	27	21A		864538	02	10A	
584715	04	08A		833308	23	12A		847791	23	10A		864539	02	05A	
597418	17	14A		833669	26	07A		8477975	30	04A		864540	02	06A	
597528	12	06A		833673	26	11A		847928	27	16A		864541	02	07A	
598715	12	10A		833674	26	12A		847929	27	02A		864542	02	08A	
638792	33	08A		833701	19	08A		847931	32	09A		864543	02	09A	
638949	33	06A		833722	27	23A		848039	12	05A		864544	02	03A	
639000	22	08A		833989	25	12A		8481875	32	04A		864545	02	02A	
639150	04	35A		834044	26	13A		8483785	31	01A		864546	02	14A	
639205	24	10A		834266	17	07A		848724	29	05A		864547	02	04A	
639426	05	31A		840193	25	06A		848864	18	07A		864548	02	11A	
647246	03	22A		840332	19	18A		861043	14	21A		864549	02	12A	
709532	33	04A		840344	27	12A		86108R	08	24A		864550	02	13A	
82518R	26	10A		840504	31	16A		86111R	12	02A		864551	02	15A	
82545R	03	32A		840507	31	14A		861132	16	06A		864566	10	33B	
825758	12	11A		840533	25	10A		861134	14	07A		864568	08	25A	
825758	32	10A		840893	30	05A		861250	10	55A		864578	09	27A	
82580R	31	12A		8410015	32	13A		861669	09	19A		864579	11	15A	
825952	27	18A		8410035	32	14A		862534	09	22A		864580	11	11A	
82635R	31	13A		841130	28	05A		862556	09	10A		864581	09	18A	
826396	23	18A		841379	25	11A		862564	08	07A		864582	12	20A	
82649R	27	10A		841774	26	14A		862596	06	36A		8714725	17	02A	
82650R	27	15A		842090	17	09A		862597	06	37A		871805	18	01A	
82659R	32	05A		842093	17	12A		863168	03	20A		872849	22	12A	
827085	19	14A		842204	25	03A		863169	03	21A		872871	13	01A	
82723R	27	20A		8423835001	20	01A		863178	11	01A		872889	33	03A	
82737R	29	04A		8423835002	20	01B		863180	11	12A		872999	22	18A	
827526	13	04A		842385	30	10A		863181	11	06A		873009	22	17A	
82782R	27	19A		842388	30	11A		8631830001	07	01A		873351	32	07A	
82783R	27	11A		842389	31	05A		863186	02	01A		942577	10	34A	
828146	21	08A		842390	28	07A		863379	14	01A		949357	12	01A	
828147	21	08B		842404	13	02A		86338200W03	01	06A		949560	07	35A	
828148	21	08C		842595	31	07A		863409	06	10A		949562000G	07	34A	
828152	15	07A		842703	29	03A		863428	13	07A		949613	03	05A	
82817R	23	03A		842870	25	04A		86354600WNB	01	10A		959378	11	04A	
82817R	23	06A		843028	25	05A		863553	09	12A		963486	21	06A	
82818R	26	01A		843228	21	03A		863558	01	01A		AP8127305	09	28A	
828217	25	13A		843517	21	07A		863559	03	01A		CM001904	24	08A	
82823R	31	10A		8435190001	21	01A		863560	03	09A		CM001904	28	06A	
82831R	22	03A		8435190002	21	01B		863599	07	15A		CM001922	28	04A	
828421	24	05A		8435190003	21	01C		863600	07	27A		CM002910	18	09A	
828480	22	19A		8435190004	21	01D		863601	07	19A		CM025707	04	31A	
828653	24	07A		843568	31	18A		86369100WNB	03	15A		CM078207	33	01A	
828662	28	02A		843963	25	07A		863692	07	42A		CM1440175	26	02A	
828717	26	06A		8440494	26	16A		863693	13	12A		CM144407	25	01A	
82871R	31	06A		844094	24	09A		863711	10	29A		CM155102	17	01A	
82878R	19	13A		844160	22	11A		863712	09	32A					
829040	31	02A		844160	31	17A		863713	09	33A					
829139	23	19A		844352	27	01A		863758	03	31A					
829206	32	06A		844582	19	16A		863762	04	28A					
829258	18	05A		844641	13	03A		863796	04	38A					
829259	18	02A		844669	32	01A		863798	04	39A					
829529	21	02A		844730	31	04A		863808	10	01A					
829534	24	01A		8447595	31	08A		863813	04	11A					
829536	24	02A		844964	17	16A		863842	10	48A					
829543	18	06A		845212	19	21A		863902	10	45A					
829593	27	03A		845320	13	09A		863904	10	57A					
829661	19	02A		845604	22	04A		863905	10	58A					
829861	33	07A		845605	22	07A		863944	15	01A					
830015	18	03A		845753	22	02A		864097	08	19A					
830056	18	10A		845861	19	25A		864098	09	08A					
830057	18	11A		846096	27	04A		864185	08	19B					
830061	19	24A		846098	27	05A		864389	06	41A					
830061	33	02A		8462415001	19	01A		86441200W4G	06	01A					
8300715	32	12A		8462415002	19	01B		86441300W4G	06	02A					
830248	24	03A		846734	28	01A		86444800WGO	05	46B					
830249	24	04A		846819	27	06A		86444800WNO	05	46A					